



Installation and Operation Manual

PIA01-001 Passenger Intercom Amplifier



SM78

ISSUE 1.00

Northern Airborne Technology Ltd.
1925 Kirschner Road
Kelowna, BC, Canada.
V1Y 4N7
Telephone (250) 763-2232
Facsimile (250) 762-3374

Issued on the authority of Northern Airborne Technology Ltd.

Copyright 2010



**PIA01-001 Passenger Intercom Amplifier
SM78 Installation and Operation Manual**

Table of Contents

Section	Title	Page
1.	Description	
1.1	Introduction	1-1
1.2	Product Description	1-1
1.3	Design Features	1-1
1.4	Specifications	1-2
1.4.1	Electrical Specifications	1-2
1.4.2	Physical Specifications	1-5
1.4.3	Environmental Specifications	1-6
1.4.4	Product Approval	1-6
2.	Installation	
2.1	Introduction	2-1
2.2	Unpacking and Inspection	2-1
2.2.1	Warranty	2-1
2.3	Continued Airworthiness	2-1
2.4	Installation Procedures	2-1
2.4.1	Warnings	2-2
2.4.2	Cautions	2-2
2.4.3	Mounting	2-3
2.4.4	Cabling and Wiring	2-3
2.4.5	Post Installation Checks	2-6
2.5	Adjustments and Connections	2-6
2.6	Accessories Required But Not Supplied	2-7
2.7	Installation Drawings	2-7
3.	Operation	
3.1	Introduction	3-1
3.2	General Information	3-1



PIA01-001 Passenger Intercom Amplifier SM78 Installation and Operation Manual

Section 1 Description

1.1 Introduction

Information in this section consists of product description, design features and specifications for the PIA01-001 Passenger Intercom Amplifier (PIA01). All derivative product information shall be contained in the applicable manual supplement, which may be obtained from Northern Airborne Technology Ltd. as required.

Review all notes, warnings and cautions.

Note: This manual contains information applicable to units MOD 4 and above.

1.2 Product Description

The PIA01 is a remote mounted Passenger Intercom Amplifier that supports up to twelve passengers together on one intercom system (six headset connections on the PIA01, each supporting two headsets in parallel, if desired). Expansion capabilities are provided through either an analog or digital ICS Tie Line connection. Only one of these ICS Tie Lines is operational at any given time.

1.3 Design Features

The PIA01 has a number of configurable system parameters providing flexibility for customized applications. The PIA01 can be configured to support one of three microphone impedances and one of three headphone impedances. The microphone and headphone impedances selected will apply to all of the PIA01 users. The headphone outputs will support mono headsets. The microphone audio is summed together as one group.

The PIA01 is initially intended for application with the Northern Airborne Technology (NAT) Digital Audio Communication System (DACS). In this configuration, the PIA01 provides intercom audio with the passengers of the Audio Management Unit (AMU) within the DACS system via the digital ICS Tie Line. The PIA01 communicates with the AMU using a serial data port. All intercom audio between the PIA01 and AMU is digitized and passed over the serial data port. When used with the DACS, the PIA01 system parameters are configured using a Personal Computer (PC) connected to the AMU via a Universal Serial Bus (USB) serial port and NAT supplied DACS Device Configuration software. The PIA01 intercom audio level and VOX level matches the corresponding levels heard by the passengers connected to the AMU.

The PIA01 can also be used as a stand-alone Passenger Intercom Amplifier. In this configuration, the PIA01 enables the analog ICS Tie Line for intercom communication with external devices. Microphone and headphone impedances are selected via discrete inputs on the PIA01 external connector. Intercom audio and VOX levels are adjusted via discrete inputs on the PIA01 external connector.

The PIA01 also features a stereo music input. The stereo signal is summed to a mono signal and routed to all headphone outputs. The music input level is configurable to support portable or automotive input levels via discrete inputs on the PIA01 external connector.



PIA01-001 Passenger Intercom Amplifier SM78 Installation and Operation Manual

1.4 Specifications

1.4.1 Electrical Specifications

Input Signals

Input Power

Normal Operating Conditions:

Nominal:	+28.0 Vdc
Maximum:	+30.3 Vdc
Minimum:	+22.0 Vdc
Emergency:	+18.0 Vdc

Abnormal Operating Conditions:

Maximum:	+32.2 Vdc
Minimum:	+20.5 Vdc

Input Current: 2.0 A maximum @ 28.0 Vdc

Microphones (PAX1 MIC through PAX6 MIC)

Three microphone impedances are available. All microphone inputs are configured to the same impedance setting via the digital ICS Tieline (digital mode) or jumper settings (analog mode).

Quantity:	6
Gain	Adjustable from -9 dB to +6 dB of nominal input level, +/- 1dB with 15 steps of adjustment (digital mode only).

Microphone (Type One) dynamic

Rated Level:	250 μ Vrms nominal to produce rated headphone output
Impedance:	5 Ω \pm 30%
Circuitry Type:	differential

Microphone (Type Two) dynamic

Rated Level:	850 μ Vrms nominal to produce rated headphone output
Impedance:	75 Ω \pm 30%
Circuitry Type:	differential

Microphone (Type Three) amplified dynamic/electret

Rated Level:	250 mVrms nominal to produce rated headphone output
Impedance:	150 Ω \pm 10%
Circuitry Type:	single ended
Mic Bias:	24 mA (TSO configuration)

Stereo Music (MUSIC R and MUSIC L)

Quantity:	1
Lo Level Input:	400 mVrms +/-10%
Hi Level Input:	2.5 Vrms +/-10%
Input Impedance:	1 k Ω \pm 10%
Circuitry Type:	differential



PIA01-001 Passenger Intercom Amplifier SM78 Installation and Operation Manual

ICS Keylines (PAX1 ICS KEY through PAX6 ICS KEY)

Quantity:	6
Logic:	active LO, no external pull up required
Input Active:	$\leq +3$ Vdc
Maximum Current:	≤ 10 mA
Input Protection:	diode protected to +45 Vdc maximum

Headphone Impedance Discrete Input (PHN IMPEDANCE)

Quantity:	1
8 Ω :	Logic: active HI, no external resistor required Input Active: $\geq +17.5$ Vdc Maximum Current: ≤ 15 mA Input Protection: diode protected to +45 Vdc maximum
150 Ω :	Logic: active Floating Input Active: No connection Maximum Current: N/A Input Protection: diode protected to +45 Vdc maximum
600 Ω :	Logic: active LO, no external pull up required Input Active: $\leq +3$ Vdc Maximum Current: ≤ 10 mA Input Protection: diode protected to +45 Vdc maximum

Microphone Impedance Discrete Input (MIC IMPEDANCE)

Quantity:	1
5 Ω :	Logic: active HI, no external resistor required Input Active: $\geq +17.5$ Vdc Maximum Current: ≤ 15 mA Input Protection: diode protected to +45 Vdc maximum
75 Ω :	Logic: active Floating Input Active: No connection Maximum Current: N/A Input Protection: diode protected to +45 Vdc maximum
150 Ω :	Logic: active LO, no external pull up required Input Active: $\leq +3$ Vdc Maximum Current: ≤ 10 mA Input Protection: diode protected to +45 Vdc maximum

ICS Tie Line Load Discrete Input (NAT ICS LEVEL)

Quantity:	1
2 Loads:	Logic: active LO, no external pull up required Input Active: $\leq +3$ Vdc Maximum Current: ≤ 10 mA Input Protection: diode protected to +45 Vdc maximum
4 Loads:	Logic: active Floating Input Active: No connection Maximum Current: N/A Input Protection: diode protected to +45 Vdc maximum



PIA01-001 Passenger Intercom Amplifier SM78 Installation and Operation Manual

Music Level Discrete Input (MUSIC LEVEL)

Quantity:		1
Lo level:	Logic:	active LO, no external pull up required
	Input Active:	$\leq +3$ Vdc
	Maximum Current:	≤ 10 mA
	Input Protection:	diode protected to +45 Vdc maximum
Hi level:	Logic:	active Floating
	Input Active:	No connection
	Maximum Current:	N/A
	Input Protection:	diode protected to +45 Vdc maximum

Intercom Volume Discrete Input (VOLUME INC/VOLUME DEC)

Quantity:		2
VOL INC:	Logic:	active LO, no external pull up required
	Input Active:	$\leq +3$ Vdc
	Maximum Current:	≤ 10 mA
	Input Protection:	diode protected to +45 Vdc maximum
VOL DEC:	Logic:	active LO, no external pull up required
	Input Active:	$\leq +3$ Vdc
	Maximum Current:	≤ 10 mA
	Input Protection:	diode protected to +45 Vdc maximum

VOX Level Discrete Input (VOX INC/VOX DEC)

Quantity:		2
VOX INC:	Logic:	active LO, no external pull up required
	Input Active:	$\leq +3$ Vdc
	Maximum Current:	≤ 10 mA
	Input Protection:	diode protected to +45 Vdc maximum
VOX DEC:	Logic:	active LO, no external pull up required
	Input Active:	$\leq +3$ Vdc
	Maximum Current:	≤ 10 mA
	Input Protection:	diode protected to +45 Vdc maximum

Output Signals

Headphones (PAX1 PHONES through PAX6 PHONES)

Three impedances are available. All headphone outputs are configured to the same impedance setting via the Digital ICS Tieline (digital mode) or jumper setting (analog mode).

Quantity:	6 mono headphone outputs
Rated Output:	≥ 250 mW into rated load
Circuitry Type:	balanced

Headphone (Type One)

Load Impedance:	$8 \Omega \pm 10\%$
Output Impedance:	$\leq 2.25 \Omega$

Headphone (Type Two)

Load Impedance:	$150 \Omega \pm 10\%$
Output Impedance:	$\leq 20 \Omega$



PIA01-001 Passenger Intercom Amplifier SM78 Installation and Operation Manual

Headphone (Type Three)
Load Impedance: 600 Ω \pm 10%
Output Impedance: \leq 60 Ω

Bi-Directional Signals

Digital ICS Tie Line (ICS TIE TX/ICS TIE RX)

Serial Data Port:

Quantity: 1
Specification: RS422
Serial Data Protocol: S/PDIF

Analog ICS Tie Line (NAT ICS TIE)

Quantity: 1
Port Impedance: 2 k Ω \pm 15%
Rated Level: 230 mVrms nominal, (2 loads)
136 mVrms nominal, (4 loads)
Circuitry Type: balanced

1.4.1.1 Audio Performance

The PIA01-001 meets the requirements of FAA TSO-C139 and RTCA/DO-214 Class Ib.

Audio Frequency Response: <3dB from 300 - 6000Hz
Volume Controls: 40dB of adjustment (intercom audio)
Crosstalk: >55dB attenuation from rated output power for input to output crosstalk and bleedthrough.
>60dB attenuation from rated input level for input to input crosstalk (except for stereo Music left and right channel inputs).

1.4.2 Physical Specifications

Height: 34.3 mm (1.35 in) maximum
Depth: 201.9 mm (7.95 in) maximum
Width: 168.9 mm (6.65 in) maximum including flanges
Weight: 0.72 kg (1.65 lbs.) maximum
Material and Finish: Brushed aluminium, conversion coated
Connectors: 1 x 50 pin D-Sub, male; Jackpost locking hardware
Installation: RS-422 Cable: 20.0 m (785.9 in) maximum
MIC Cable: 5.0 m (196.7 in) maximum
PHN Cable: 5.0 m (196.7 in) maximum
Mounting: Bulkhead Mount (four 10-32 screws)



PIA01-001 Passenger Intercom Amplifier SM78 Installation and Operation Manual

1.4.3 Environmental Specifications

The PIA01-001 has been tested to the environmental conditions listed below. Environmental categories for which TSO compliance has been demonstrated are listed on the Environmental Qualification Form in Section 2 of this manual.

Temperature:	-40 to +70° C (Operating) -45 and +85° C (Short Time Operating) -55 to +85° C (Ground survival)
Altitude:	50,000 feet max
Humidity:	95% non-condensing
Shock:	Operational Shock; 6 g for 11 ms Crash Safety (impulse); 20 g for 11 ms Crash Safety (sustained); 20 g for 3 s
Vibration:	RTCA/DO-160E category [(SBM)(U2FF1)]

1.4.4 Product Approval

Refer to section 2.4.2 Cautions (Installation Limitations) for details of limitations required for TSO-C139 compliance.

FAA: TSO-C139 (RTCA/DO-214 Class Ib, RTCA/DO-160E, RTCA/DO-178B Level D)

This TSO approval is only applicable to units incorporating MODs 1-4 inclusive and higher.

Section 1 ends



PIA01-001 Passenger Intercom Amplifier SM78 Installation and Operation Manual

Section 2 Installation

2.1 Introduction

Information in this section consists of unpacking and inspection procedures, installation procedures, post-installation checks and installation drawings for the PIA01-001 Passenger Intercom Amplifier.

Review all notes, warnings and cautions.

2.2 Unpacking and Inspection

Unpack the equipment carefully and locate the warranty card. Inspect the unit visually for damage due to shipping and report all such claims immediately to the carrier involved. Check that all items listed below are present before proceeding and report any shortage immediately to your supplier:

- Warranty Card
- Certificate of Conformity or Release Certification

2.2.1 Warranty

All Northern Airborne Technology Ltd. products are warranted for 2 years from date of installation by an authorized Northern Airborne Technology Ltd. dealer, to be free of defects in workmanship or performance. This warranty covers all materials and labour, but is exclusive of any transport to deliver the defective unit to and from Northern Airborne Technology Ltd. or its designated warranty repair center, or any labour to remove or re-install the defective unit in the aircraft. Contact Northern Airborne Technology Ltd. for any questions regarding this warranty, its applicability to your units and/or for return authorization. Northern Airborne Technology Ltd. is the final arbitrator concerning warranty administration. Units which have been physically damaged, burned, immersed in water or otherwise abused beyond the scope of normal use will not be considered for warranty. **WARRANTY IS VOID UNLESS THE PRODUCT IS INSTALLED BY AN AUTHORIZED NORTHERN AIRBORNE TECHNOLOGY LTD. DEALER.** Product for which a warranty card is not returned shall be warranted from date of manufacture.

2.3 Continued Airworthiness

Maintenance of the PIA01-001 Passenger Intercom Amplifier is 'on condition' only. Periodic maintenance of this product is not required.

2.4 Installation Procedures

Installation Notice

This product must be installed in accordance with the installation instructions provided in the latest issue of this Installation and Operation Manual. Check the Publication Index at www.northernairborne.com for the issue status of the manual. The latest issue of the manual may be downloaded from the same website. All risk associated with installation of this product contrary to these instructions shall be the responsibility of the installing agency.



PIA01-001 Passenger Intercom Amplifier SM78 Installation and Operation Manual

2.4.1 Warnings

WARNING:
High volume settings can cause hearing damage.
Set the headset volume control to the minimum setting prior to conducting tests, and slowly increase the volume to a comfortable listening level.

2.4.2 Cautions

CAUTION:
Do not bundle any lines from this unit with transmitter coax feed lines. Do not bundle any logic, audio, or DC power lines from this unit with 400 Hz synchro wiring or AC power lines. Do not position this unit next to any device with a strong alternating magnetic field such as an inverter, motor or blower, or significant audio interference will result.

In all installations, use shielded cable exactly as shown, and ground only as indicated. Significant problems may result from not following these guidelines.

Failure to follow the installation and wiring instructions provided in this manual for power and ground connections, including the rating of the circuit breaker, may lead to damage in the power input circuitry of the unit.

CAUTION:
Installation Limitations

1. Approval Settings
The PIA01 has only been tested to demonstrate compliance with the requirements of TSO-C139 with the installation settings listed below. Settings other than those listed are not approved.

Item	Setting
Microphone Impedance	150 Ohm
Headphone Impedance	150 Ohm

These settings are applied by connector pin strapping (analog mode) or via the digital ICS Tieline (digital mode).

2. Software Approval
A deviation to TSO-C139 has been granted by the FAA to allow the software to be developed to RTCA/DO178B Level D in lieu of Level C. As a result the PIA01 must not be used for flight crew intercommunication or radio communication functions. Provision must be available in the aircraft audio system to permit the flight crew to disconnect audio from the PIA01 from their headphone audio.



PIA01-001 Passenger Intercom Amplifier SM78 Installation and Operation Manual

2.4.3 Mounting

The PIA01 can be bulkhead mounted in any orientation using four 10-32 screws. No shock or vibration isolators are required.

The PIA01 must be mounted to a clean metal surface which is electrically bonded to the aircraft ground plane. The unit is finished with a coating which prevents corrosion. This film is electrically conductive and should not be removed for electrical bonding.

2.4.4 Cabling and Wiring

All wire shall be selected in accordance with the original aircraft manufacturer's Maintenance Instructions or AC43.13-1B Change 1, Paragraphs 11-76 through 11-78. Unshielded wire types shall qualify to MIL-W-22759 as specified in AC43.13-1B Change 1, Paragraphs 11-85, 11-86, and listed in Table 11-11. For shielded wire applications, use Tefzel MIL-C-27500 shielded wire with solder sleeves (for shield terminations) to make the most compact and easily terminated interconnect. Follow the connector map in Section 2.7 as required.

Allow 3" from the end of the shielded wiring to the shield termination to allow the connector hood to be easily installed. Reference the interconnect drawing in Section 2.7 for shield termination details. Note that the hood is a 'clamshell' hood, and is installed after the wiring is complete.

Maintain wire segregation and route wiring in accordance with the original aircraft manufacturers Maintenance Instructions.

Unless otherwise noted, all wiring shall be a minimum of 22 AWG, except power and ground lines, which shall be a minimum of 20 AWG. Reference the Interconnect drawing for additional specifications. Check that the ground connection is clean and well secured, and that it shares no path with any electrically noisy aircraft accessories such as blowers, turn and bank instruments or similar loads. Power to this unit must be supplied from a separate circuit breaker or fuse (fast blow), and not attached to any other circuit breaker without additional protection. Verify that the selected circuit breaker size and wire gauge are adequate for the installation using the techniques specified in AC43.13-1B Change 1, Paragraphs 11-47 through 11-51 and 11-66 through 11-69.

2.4.4.1 Interconnect Discrettes

2.4.4.1.1 Intercom Volume Input (VOLUME INC / VOLUME DEC)

The PIA01 has two Intercom Volume Inputs for adjusting the Intercom Audio Level at the headphone outputs. Each activation of the volume switch causes one volume level change of 2 dB. On power-up the volume level defaults to maximum.

These inputs are only active when the PIA01 is operating in analog mode. In digital mode the PIA01 Intercom Volume level is controlled by data on the Digital ICS Tieline.



PIA01-001 Passenger Intercom Amplifier SM78 Installation and Operation Manual

2.4.4.1.2 VOX Level Input (VOX INC / VOX DEC)

The PIA01 has two VOX Level Inputs for adjusting the VOX threshold for all users. Each activation of the VOX switch causes one VOX level change of 2 dB. On power-up the VOX level defaults to approximately 10 dB above the minimum setting. The maximum setting is for keyed ICS operation; the users ICS Key switch must be activated to talk on the intercom.

These inputs are only active when the PIA01 is operating in analog mode. In digital mode the PIA01 VOX level is controlled by data on the Digital ICS Tieline.

2.4.4.1.3 Headphone Impedance Input (PHN IMPEDANCE)

The PIA01 has one Headphone Impedance Input for selecting the headphone impedance setting for all users. Three settings are available, alternate impedance with the input grounded, standard impedance with the input open circuit, and low impedance with the input connected to 28V dc. For TSO approval this input must be open circuit.

This input is only active when the PIA01 is operating in analog mode. In digital mode the PIA01 Headphone Impedance setting is controlled by data on the Digital ICS Tieline.

2.4.4.1.4 Microphone Impedance Input (MIC IMPEDANCE)

The PIA01 has one Microphone Impedance Input for selecting the microphone impedance setting for all users. Three settings are available, standard impedance with the input grounded, alternate impedance with the input open circuit, and low impedance with the input connected to 28Vdc. For TSO approval this input must be connected to ground.

This input is only active when the PIA01 is operating in analog mode. In digital mode the PIA01 Microphone Impedance setting is controlled by data on the Digital ICS Tieline.

2.4.4.1.5 ICS Tieline Load Input (NAT ICS LEVEL)

The PIA01 has one ICS Tieline Load Input for selecting the number of ICS Tieline loads on the Analog ICS Tieline. Two settings are available, two loads and four loads.

This input is only active when the PIA01 is operating in analog mode. In digital mode the PIA01 the Analog ICS Tieline does not operate.

2.4.4.1.6 Music Level Input (MUSIC LEVEL)

The PIA01 has one Music Level Input for selecting the level setting for the Music Input. Two settings are available, low level with the input grounded, and high level with the input open circuit.

This input is only active when the PIA01 is operating in analog mode. In digital mode the PIA01 Music Input Level is controlled by data on the Digital ICS Tieline.



PIA01-001 Passenger Intercom Amplifier SM78 Installation and Operation Manual

2.4.4.2 Interconnect Audio

2.4.4.2.1 Microphone Inputs

The PIA01 has six Microphone Inputs. Each Microphone Input has independent VOX operation, an independent user ICS Key input, and can support one or two microphones connected in parallel. With two microphones connected operation may be degraded; TSO minimum performance standard operation has only been demonstrated with one microphone connected to each Microphone Input.

2.4.4.2.2 Headphone Outputs

The PIA01 has six mono Headphone Outputs. Each Headphone Output can support one or two headphones connected in parallel. With two headphones connected operation may be degraded; TSO minimum performance standard operation has only been demonstrated with one headphone connected to each Headphone Output.

2.4.4.2.3 Stereo Music Input

The PIA01 has one Stereo Music Input. The MUSIC L and MUSIC R inputs are summed together inside the PIA01 to provide a monaural music audio to all headphone outputs. The music is not included in the audio signal on the ICS Tieline. The music is muted to the headphones whenever a user is talking on the intercom.

2.4.4.2.4 ICS Tieline

The PIA01 can support ICS communications with an external device on either an analog or a digital tieline, but not both.

2.4.4.2.4.1 ICS Mode

The PIA01 operates in either Digital mode or Analog mode depending on the availability of ICS Tieline signals. On power-up the PIA01 will default to analog mode operation, but continuously looks for a signal on the digital ICS tieline input. If the PIA01 detects a valid signal on the digital ICS tieline input it will enter digital mode; if the PIA01 loses the signal on the digital ICS tieline it will remain in digital mode using the configuration settings last received from the digital ICS tieline.

Note: The digital and analog modes only describe the ICS tieline interface. Internally the unit processes audio digitally in both modes.

2.4.4.2.4.2 Analog ICS Tieline

The Analog ICS Tieline can be configured to support standard NAT analog audio products. Refer to the interconnect drawing in section 2.7 to ensure that the tieline loading is correct.

The Analog ICS Tieline is disabled when the PIA01 is operating in digital mode.

2.4.4.2.4.3 Digital ICS Tieline

The Digital ICS Tieline allows connection of the PIA01 to one external device. The PIA01 sends digital audio to the external device, and receives digital audio and configuration data from the external device.



PIA01-001 Passenger Intercom Amplifier SM78 Installation and Operation Manual

2.4.5 Post Installation Checks

2.4.5.1 Voltage/Resistance Checks

Do not attach the PIA01 until the following conditions are met.

Check the following:

- a) Check pin <1> for +28 Vdc relative to ground.
- b) Check pin <34> for power ground (less than 0.5Ω).
- c) Check pin <18> for chassis ground (less than 0.5Ω).
- d) Check pins <2> <19> <35> and <36> for ground (less than 0.5Ω) when the appropriate switches are closed.
- e) Check pins <37> <38> <39> <40> <41> and <42> for ground (less than 0.5Ω) when the appropriate switches are keyed.
- f) Check pins <44> for MIC impedance ground (less than 0.5Ω).
- g) Check pin <49> for ground (less than 0.5Ω) when 2 NAT loads is selected.
- h) Check pin <27> for ground (less than 0.5Ω) when music level LO is selected.

2.4.5.2 Power On Checks

WARNING:
High volume settings can cause hearing damage.
Set the headset volume control to the minimum setting prior to conducting tests, and slowly increase the volume to a comfortable listening level.

Power up the aircraft's systems and verify normal operation of all functions of the PIA01.

Upon satisfactory completion of all functional/operational checks, make all required log book entries, electrical load, weight and balance amendments and other documentation as required by your local regulatory agency.

2.5 Adjustments and Connections

When installed in an audio communications system such as the Northern Airborne Technology Ltd DACS, all adjustments are made through the DACS Device Configuration Software (DevCs) application. Refer to the SM76 AMU50-001 Audio Management Unit Installation and Operation Manual and the DevCs Installation and Operation manual for information on connection and operation of the DevCs.



PIA01-001 Passenger Intercom Amplifier SM78 Installation and Operation Manual

2.6 Accessories Required But Not Supplied

Installation kit p/n PIA01-IKC (crimp) is required to complete the installation. The kit consists of the following:

Quantity	Description	Part No.
1	Connector, D-Sub Socket, Crimp 50 pin Housing	20-21-R50
50	Contact Crimp Socket	20-26-901
1	Hood, D-Sub, Metal	20-28-003
1	Shield Termination, Tag Ring	20-30-416











2.7 Installation Drawings

DOCUMENT	REV.	DESCRIPTION	TYPE
PIA01-001			
PIA01\001\403-0	1.00	Passenger Intercom Amplifier	Interconnect (3 sheets)
PIA01\001\405-0	1.00	Passenger Intercom Amplifier	Connector Map
PIA01\001\521-0	1.00	Passenger Intercom Amplifier	Environmental Qualification Form
PIA01\001\922-0	1.10	Passenger Intercom Amplifier	Mechanical Installation

Section 2 ends following the above documents

PIA01-001 INSTALLATION NOTES



NOTES:

- 1 ALL WIRES SHOULD BE 22 AWG UNLESS OTHERWISE SPECIFIED. ALL WIRE SHOULD BE IN ACCORDANCE WITH MIL-W-22759. ALL SHIELDED WIRE/CABLE SHOULD BE IN ACCORDANCE WITH MIL-C-27500 OR EQUIVALENT.
-  2 CABLE LENGTH NOT TO EXCEED 0.7 FT [0.2 M].
-  3 PROVIDE CONNECTION TO GROUND OR LEAVE OPEN PER SYSTEM REQUIREMENTS.
-  4 CABLE LENGTH NOT TO EXCEED 16.4 FT [5 M].
-  5 SYSTEM CROSSTALK WILL BE EFFECTED BY STYLE OF HEADSET AND JACK. CHECK SPECIFICATIONS AND SYSTEM REQUIREMENTS BEFORE SELECTING AND INSTALLING SAME.
-  6 SHIELD RETURNS SHOULD BE GROUNDED TO CONNECTOR BACK SHELL (METAL TYPE), IF USED. OTHERWISE, GROUND TO LOCAL AIRFRAME GROUND.
-  7 PROVIDE SHORT RETURN TO AIRFRAME GROUND.
-  8 SEE SHEET 3 FOR EXAMPLES OF LOADING CONNECTIONS.
-  9 CABLE LENGTH NOT TO EXCEED 3.3 FT [1.0 M].
-  10 WHEN CONNECTIONS ARE MADE TO PIA01 J101 PINS 45-48, THE NAT ICS TIE LINE (PIA01 J101 PINS 17 & 50) IS DISABLED. USE OPTION 3 LOADING CONNECTION ON SHEET 3.
-  11 FOR ALTERNATE MICROPHONE AND PHONE IMPEDANCE CONFIGURATIONS REFER TO THE INSTALLATION AND OPERATIONS MANUAL.

DEFINITIONS:

- N/C: NO CONNECTION. THE PIN IS NOT CONNECTED TO ANYTHING INTERNALLY, AND THEREFORE SHALL HAVE NO CONNECTION EXTERNALLY.
- N/C SPARE: NO CONNECTION INTERNALLY, BUT A SPARE WIRE SHALL BE INSTALLED IN THE WIRE HARNESS.
- RESERVED: MAY BE CONNECTED AND USED IN THE FUTURE. THE CIRCUITRY MAY BE PRESENT OR ADDED TO ACTIVATE THE FUNCTION. THE PIN MAY BE USED FOR TEST PURPOSES. THERE IS NO EXTERNAL CONNECTION.
- RESERVED SPARE: RESERVED, BUT INSTRUCTIONS SHALL BE FOLLOWED TO ACTIVATE THE CIRCUITRY. A SPARE WIRE SHALL BE INSTALLED IN THE WIRE HARNESS.

CONFIDENTIAL AND PROPRIETARY TO NAT LTD.

DESIGNED	KV	 NAT NORTHERN AIRBORNE TECHNOLOGY LTD.				
DRAWN	KV/MWS					
DATE	JUN 29/09	TITLE PASSENGER INTERCOM AMPLIFIER				
CHECKED						
APPROVED		SIZE A	CAGE CODE 3AB01	PART NO. PIA01-001	REV. 1.00	SHEET 1/3
FILE	403-0.DWG	DWG. TYPE	INTERCONNECT	DWG. NO.	PIA01\001\403-0	

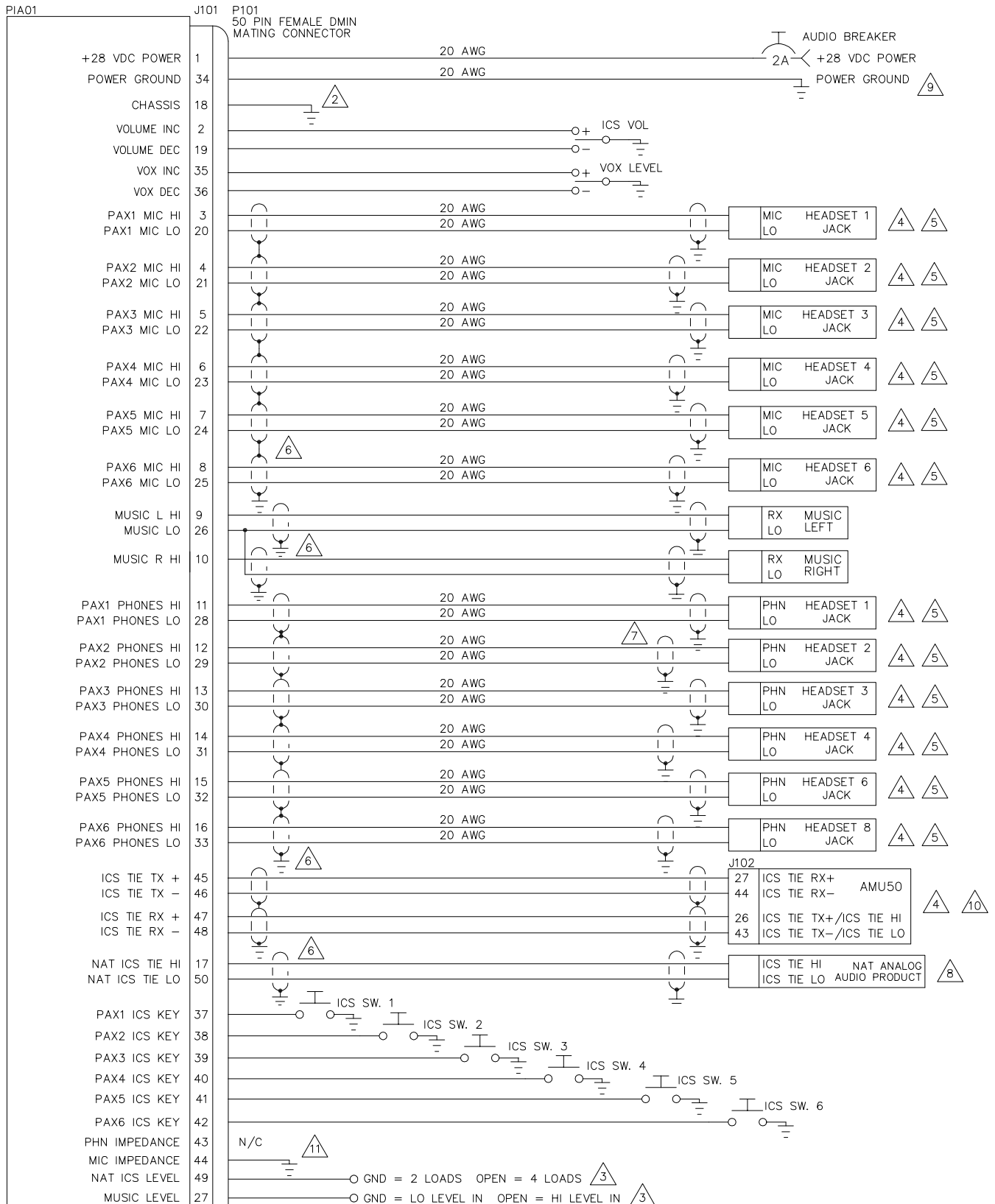

CONFIDENTIAL AND PROPRIETARY TO NAT LTD.

DESIGNED	KV	NAT NORTHERN AIRBORNE TECHNOLOGY LTD.				
DRAWN	KV/MWS					
DATE	JUN 29/09	TITLE				
CHECKED	NAT 255	PASSENGER INTERCOM AMPLIFIER				
APPROVED	NAT 114	SIZE	CAGE CODE	PART NO.	REV.	SHEET
		A	3AB01	PIA01-001	1.00	2/3
FILE	403-0.DWG	DWG. TYPE	INTERCONNECT	DWG. NO.	PIA01\001\403-1	

OPTION 1: NAT 2 LOADS (PIN 49) = GND
 PIA01 CONNECTED TO TWO NAT ANALOG AUDIO PRODUCTS WITH
 2k Ohm TIE LINE LOADS.

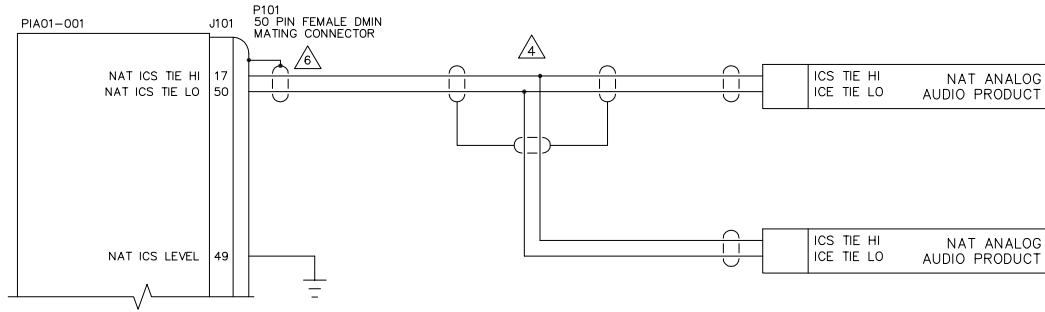

OPTION 2: NAT 2 LOADS (PIN 49) = GND
 PIA01 CONNECTED TO ONE NAT ANALOG AUDIO PRODUCT WITH 2k
 Ohm TIE LINE LOAD AND ONE 2k Ohm RESISTIVE LOAD.

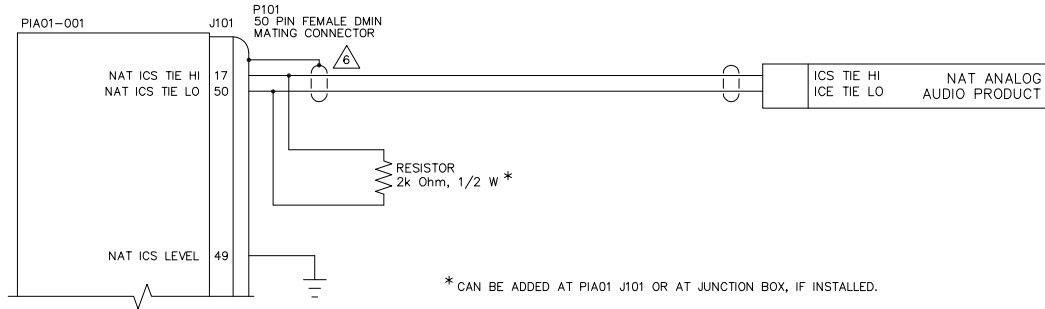

OPTION 3: NAT 2 LOADS (PIN 49) = GND
 NO NAT ANALOG AUDIO PRODUCT CONNECTED, PIA01 REQUIRES 1k
 Ohm RESISTIVE LOAD.

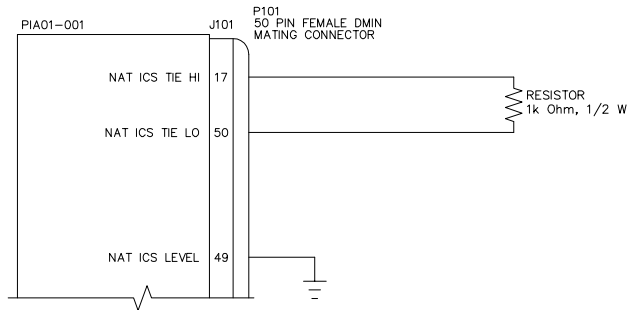

OPTION 4: NAT 4 LOADS (PIN 49) = OPEN
 PIA01 CONNECTED TO FOUR NAT ANALOG AUDIO PRODUCTS WITH
 2 KOhm LINE LOADS.

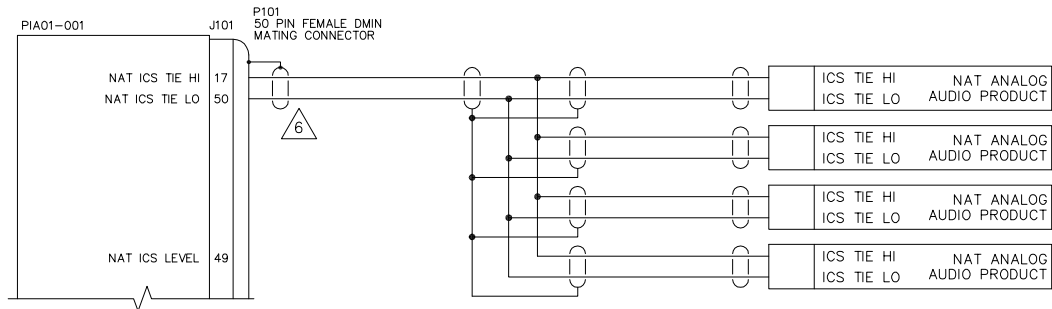

CONFIDENTIAL AND PROPRIETARY TO NAT LTD.

DESIGNED	KV	 NAT NORTHERN AIRBORNE TECHNOLOGY LTD.	TITLE PASSENGER INTERCOM AMPLIFIER			
DRAWN	KV/MWS					
DATE	JUN 29/09					
CHECKED	NAT 255					
APPROVED	NAT 114	SIZE A	CAGE CODE 3AB01	PART NO. PIA01-001	REV. 1.00	SHEET 3/3
FILE	403-0.DWG	DWG. TYPE	INTERCONNECT	DWG. NO.	PIA01\001\403-2	

P101

50 PIN D-MIN SOCKET
MATING CONNECTOR

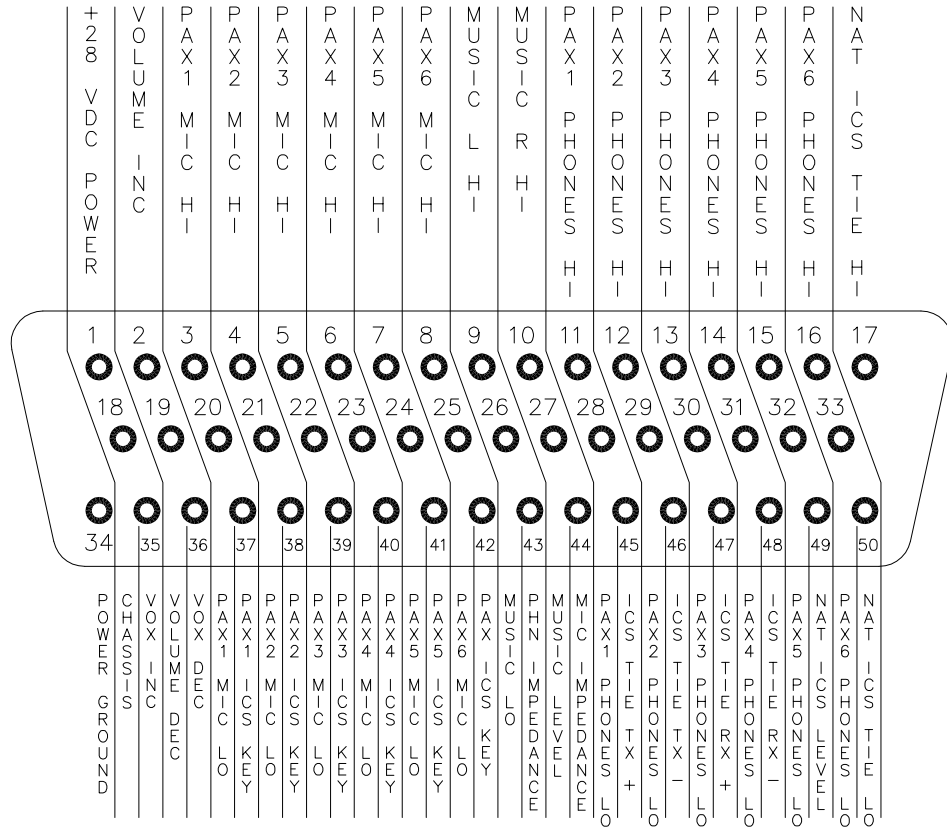

CONFIDENTIAL AND PROPRIETARY TO NAT LTD.

DESIGNED	KV	 NAT NORTHERN AIRBORNE TECHNOLOGY LTD.				
DRAWN	MWS					
DATE	JUN 01/09	TITLE				PASSENGER INTERCOM AMPLIFIER
CHECKED	NAT 255					
APPROVED	NAT 114	SIZE	CAGE CODE	PART NO.	REV.	SHEET
		A	3AB01	PIA01-001	1.00	1/1
FILE	405-0.DWG	DWG. TYPE CONNECTOR MAP			DWG. NO. PIA01\001\405-0	



ENVIRONMENTAL QUALIFICATION FORM

Description: Passenger Intercom Amplifier Document #: PIA01\001\521-0

NAT Part #: PIA01-001 TSO #: TSO-C139

Manufacturer's Specification and/or Other Applicable Specification: _____

RTCA/DO-160E, RTCA/DO-214

Manufacturer: Wulfsberg Electronics Division

Address: 6400 Wilkinson Drive, Prescott, AZ USA 86301

Prepared By: NAT 226	Checked By: NAT 231	NAT 281	Approved By: NAT 149
--------------------------------	-------------------------------	-------------------	--------------------------------

Conditions	Section	Description of Conducted Tests
Temperature and Altitude	4.0	Category [(A4)(D1)-]
Ground Survival Low Temperature	4.5.1	-55° C
Short-Time Operating Low Temp.	4.5.1	-45° C
Operating Low Temperature	4.5.2	-40° C
Ground Survival High Temperature	4.5.3	+85° C
Short-Time Operating High Temp.	4.5.3	+70° C
Operating High Temperature	4.5.4	+70° C
In-flight Loss of Cooling	4.5.5	N/A. No forced air cooling.
Altitude	4.6.1	+50,000 ft (+15,240 m)
Decompression	4.6.2	+8,000 ft to +50,000 ft (+2,438 m to + 15,240 m)
Overpressure	4.6.3	-15,000 ft (-4,752 m)
Temperature Variation	5.0	Category B.
Humidity	6.0	Category B.
Operational Shocks and Crash Safety	7.0	Category B.
Operational Shocks	7.2.2	Alternate Test Procedure.
Crash Safety	7.3.2	Alternate Test Procedure (Impulse).
	7.3.3	Test Procedure 2 (Sustained), Unknown or Random orientation in aircraft.
Vibration	8.0	Category [(SBM)(U2FF1)] (without shock mounts).

Conditions	Section	Description of Conducted Tests
Explosive Atmosphere	9.0	Category X, no test performed.
Waterproofness	10.0	Category X, no test performed.
Fluids Susceptibility	11.0	Category X, no test performed.
Sand and Dust	12.0	Category X, no test performed.
Fungus	13.0	Category X, no test performed.
Salt Fog	14.0	Category X, no test performed.
Magnetic Effect	15.0	Category Z.
Power input	16.0	Category Z. <ul style="list-style-type: none"> • The system was tested to DO-160E subparagraph 16.6.1.3 b, requirement for equipment with digital circuits. • The system was tested to DO-160E subparagraph 16.6.1.1 b (3) Emergency Operating Voltage conditions. • The system was tested to DO-160E subparagraph 16.6.2.2 Low Voltage Conditions
Voltage Spike	17.0	Category A.
Audio Frequency Susceptibility	18.0	Category Z.
Induced Signal Susceptibility	19.0	Category [ZC].
Radio Frequency Susceptibility	20.0	Category [RR].
Radio Frequency Emission	21.0	Category H.
Lightning Induced Transient Susceptibility	22.0	Category [A3J33].
Lightning Direct Effects test	23.0	Category X, no test performed.
Icing	24.0	Category X, no test performed.



Conditions	Section	Description of Conducted Tests
Electrostatic Discharge	25.0	Category X, no test performed.
Fire, Flammability	26.0	Category X, no test performed.
Other Tests		

REMARKS

- DO-160E, Sections 4 to 8, and 15 to 17 tests were conducted at Northern Airborne Technology Ltd. (NAT) in Kelowna, BC on PIA01-001.
- DO-160E, Sections 18 to 22 tests were conducted at CKC Laboratories in Bothell, WA on PIA01-001.
- Testing was performed between Oct 6th and Nov 26th 2009.

End of Environmental Qualification Form

REVISIONS			
REV	DESCRIPTION	DATE	BY
1.10	DOCCRO2908 - LABELS RESIZED & BARCODE ADDED.	MAR 04/10	MWS

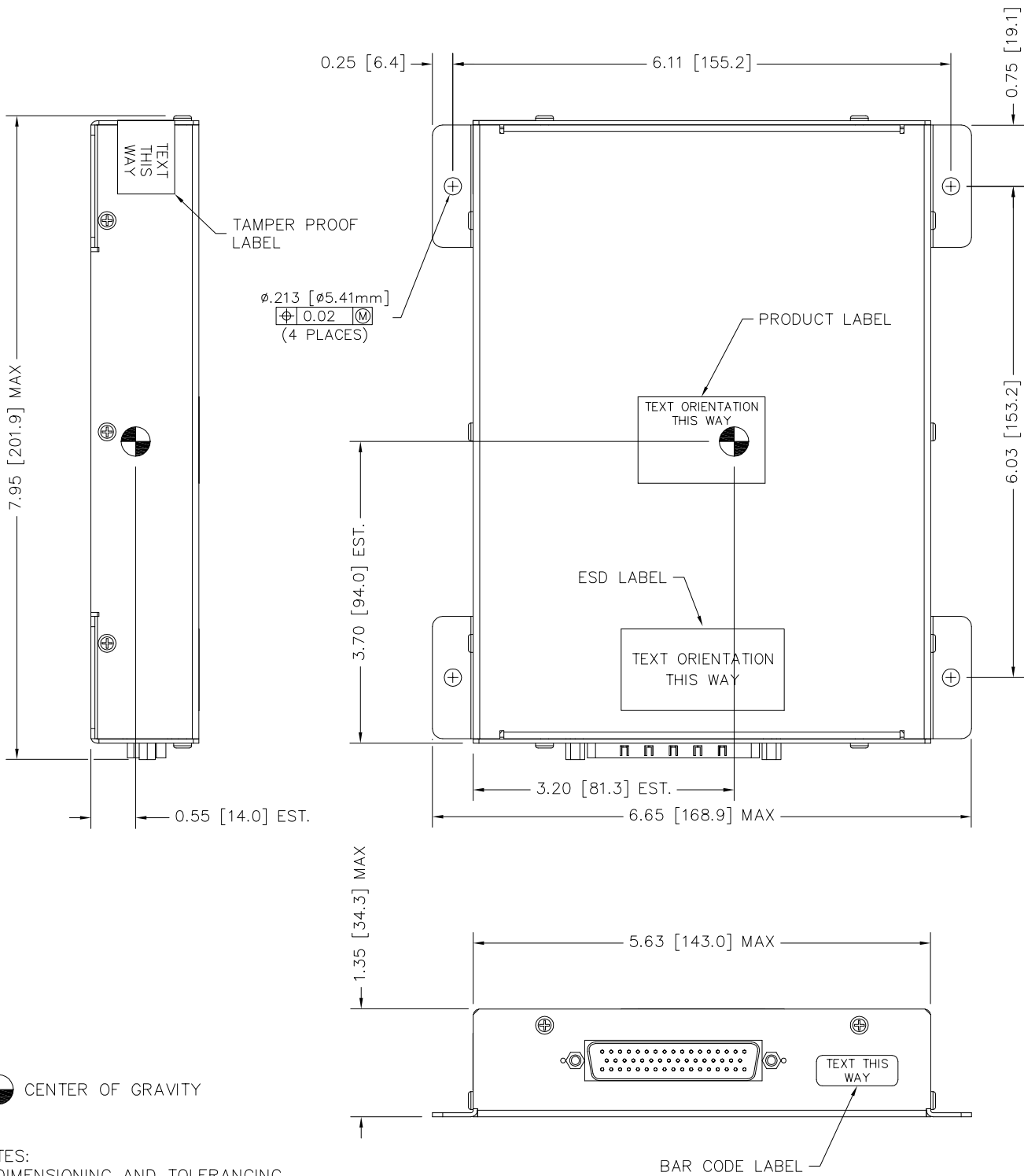

- NOTES:
- DIMENSIONING AND TOLERANCING IN ACCORDANCE WITH ASME Y14.5M-1994
 - WEIGHT: 1.65 lbs. (0.75 Kg) MAX
1.35 lbs. (0.61 Kg) MIN

CONFIDENTIAL AND PROPRIETARY TO NAT LTD.

TOLERANCES UNLESS STATED OTHERWISE 0.X=+/-0.030 0.XX=+/-0.010 0.XXX=+/-0.005 0.XXXX=+/-0.002 ANGLE=+/- 0.5 DEG.	DIMENSIONS IN INCHES	DESIGNED	KV	NAT NORTHERN AIRBORNE TECHNOLOGY LTD.									
	THIRD ANGLE PROJECTION	DRAWN	MWS										
WEIGHT: SEE NOTE 2.	MATERIAL: -	DATE	JUN 16/09	TITLE									
		CHECKED	NAT 231	NAT 255	PASSENGER INTERCOM AMPLIFIER								
FINISH: -	APPROVED	FILE	922-0.DWG	SIZE	A	CAGE CODE	3AB01	PART NO.	PIA01-001	REV.	1.10	SHEET	1/1
				DWG. TYPE	MECH. INSTALLATION	DWG. NO.	PIA01\001\922-0						



PIA01-001 Passenger Intercom Amplifier SM78 Installation and Operation Manual

Section 3 Operation

3.1 Introduction

Information in this section consists of the functional and operational procedures for the PIA01-001 Passenger Intercom Amplifier (PIA01).

3.2 General Information

The PIA01 is a remote mounted Passenger Intercom Amplifier that supports up to twelve passengers together on one intercom system (six headset connections on the PIA01, each supporting two headsets in parallel, if desired). Expansion capabilities are provided through either an analog or digital ICS Tie Line connection. Only one of these ICS Tie Lines is operational at any given time.

The PIA01-001 Passenger Intercom Amplifier has no operator accessible controls.

Section 3 ends
