



SM74

**AA30-301
Expansion Panel**



INSTALLATION AND OPERATION MANUAL

REV 4.10 October 16, 2006

**Northern Airborne Technology Ltd.
1925 Kirschner Road
Kelowna, BC, Canada.
V1Y 4N7**

**Telephone (250) 763-2232
Facsimile (250) 762-3374**

Copyright 2006 by Northern Airborne Technology

Table of Contents

Section	Title	Page
<hr/>		
1	Description	
<hr/>		
1.1	Introduction	1-1
1.2	Purpose of Equipment	1-1
1.3	Features	1-1
1.4	Specifications	1-1
1.4.1	Electrical Specifications	1-1
1.4.2	Physical Specifications	1-3
1.4.3	Environmental Specifications	1-3
1.4.4	Certification	1-4
2	Installation	
<hr/>		
2.1	Introduction	2-1
2.2	Unpacking and Inspection	2-1
2.2.1	Warranty	2-1
2.3	Installation Procedures	2-1
2.3.1	Warnings	2-1
2.3.2	Cautions	2-2
2.3.3	Cabling and Wiring	2-2
2.3.4	Post-Installation Checks	2-2
2.3.5	Adjustments	2-3
2.4	Continued Airworthiness	2-3
2.5	Accessories Required But Not Supplied	2-4
2.6	Installation Drawings	2-4
3	Operation	
<hr/>		
3.1	Introduction	3-1
3.2	General	3-1
3.3	Controls and Indicators	3-1
3.3.1	Transmitter Selection	3-2
3.3.2	Receiver Selection	3-2

Section 1 Description

1.1 Introduction

This manual contains information on the AA30-301 Expansion Panel. All derivative products will be covered by manual supplements, which can be obtained from NAT as required.

Information in this section consists of purpose of equipment, features and specifications.

1.2 Purpose of Equipment

The AA30-301 is a Dzus-mounted 4-transceiver radio receiver expansion panel, designed to work in conjunction with the 380-series Audio Selector Panels.

1.3 Features

The AA30-301 provides four ganged transmitter selector pushbutton switches and four receiver level panel potentiometers, each with an integral push-in / push-out selector switch, and utilizes the subassembly from a 247 Audio Mixing Amplifier for signal mixing, amplification and processing.

The AA30-301 is designed to be used in conjunction with a 380 panel to expand a single 380-series transmit microphone output into 4 outputs, and to expand a single 380-series receive audio input into 4 inputs.

The AA30-301 permits the audio system to support more receivers/transceivers than a single 380-series panel is capable of individually.

1.4 Specifications

1.4.1 Electrical Specifications

<u>Power Supply</u>	Linear regulated supply with input reverse-polarity and overvoltage protection.	
Operating:	Nominal	28.0 Vdc
	Minimum	22.0 Vdc
	Maximum	30.3 Vdc
	Current	0.18 A max. (0.04 A nom.)
Lighting:	Nominal	28.0 Vdc
	Maximum	30.3 Vdc
	Current	0.25 A max. (0.17 A nom.)

Input Signals

Description	Q'ty	Level	Impedance	Circuitry Type
Receiver Audio (J101) COM1 RX IN COM2 RX IN COM3 RX IN COM4 RX IN	4	Rated: 5.5 Vrms Range: 0.8 to 8.0 Vrms	2.1 k Ω	audio, unbalanced
Transmitter Mic (J102) COM MIC IN	1	250 mVrms nominal	n/a	direct connection through switch contact
Transmitter Key (J102) COM KEY IN	1	1 A max.	n/a	direct connection through switch contact

Output Signals

Description	Q'ty	Level	Impedance	Circuitry Type
Receiver Audio (J101) RX AUDIO OUT	1	Rated: 4.0 Vrms [27 mW]	Output: 100 Ω Rated Load: 600 Ω	audio, unbalanced
Transmitter Mic (J102) COM1 MIC OUT COM2 MIC OUT COM3 MIC OUT COM4 MIC OUT	4	n/a	n/a	direct connection, switch contact
Transmitter Key (J102) COM1 KEY OUT COM2 KEY OUT COM3 KEY OUT COM4 KEY OUT	4	n/a	n/a	direct connection, switch contact

1.4.1.1 Audio Performance (TSO-C139 and RTCA/DO-214 Class Ib)

Applicable to serial numbers 3001 and above.

Audio Frequency Response	≤ 3 dB variance, 300 to 5500 Hz
Spurious Response	≥ 50 dB below Rated Output Power
Distortion	$\leq 10\%$ at Rated Output Power $\leq 3\%$ THD+N at 10% Rated Output Power
Output Regulation	≤ 3 dB change

Crosstalk:	Input to Output	≥55 dB below reference signal
	Input to Input	≥60 dB below reference signal
	Input to Mic Output	≤1.0 mV
Intermodulation Distortion		≥30 dB below reference tones
Audio Noise without signal		≥50 dB below Rated Output Power
Signal plus noise degradation		>9 dB signal plus noise-to-noise

1.4.2 Physical Specifications

Height		1.14" (28.8 mm) max
Depth behind panel		6.22" (158.0 mm) max excluding connectors
Width		5.02" (127.5 mm) max behind panel
Weight		1.15 lb (0.52 kg) max
Mounting		Dzus rail, 4 fasteners 5.366" horizontal spacing, 0.750" vertical spacing
Faceplate		Laser-engraved edge-lit panel with blue/white lighting
Material/Finish		Chassis and cover are 5052-H32 brushed aluminum with chromate conversion finish.
Connectors:	J101	Receive I/O and Power Connections One male 25-pin D-subminiature connector with jackpost hardware
	J102	Mic and Key I/O Connections: One female 25-pin D-subminiature connector with jackpost hardware
Installation kit:		AA12-IKC (D25P25SL-IKC)

1.4.3 Environmental Specifications

Temperature	-55 °C to +70 °C
Altitude	+55,000 ft.
Humidity	>95%, 48 hours
Shock	6g for 11 ms in all axes
Qualification:	

Up to serial number 3000:

Internal Model 247 amplifier subassembly meets the requirements of TSO-C50c and RTCA/DO-160C Env. Cat. [A2F2]-BA[CL]XXXXXXZ[BZ]AAATZ[XXC2]XX.

Serial number 3001 and higher:

RTCA/DO-160E Env. Cat. [(A2)(F2)-]BAB[(RBB1)(SM)]XXXXXXZZAZ[AC][TT]M[XXC1X]XXXX

Note: Refer to the Environmental Qualification Form in Section 2.6 of this manual for complete details of the environmental categories.

1.4.4 Certification

Applicable to serial number 3001 and above:

FAA TSO-C139	Aircraft Audio Systems and Equipment
RTCA DO-214 Class Ib	Audio Systems characteristics and minimum operational performance standards for audio systems and equipment.

End of section 1

Section 2 Installation

2.1 Introduction

Information in this section consists of: unpacking and inspection procedures, installation procedures, post-installation checks, and installation drawings.

2.2 Unpacking and Inspection

Unpack the equipment carefully and locate the warranty card. Inspect the unit visually for damage due to shipping and report all such claims immediately to the carrier involved. Note that each unit should have the following:

- AA30-301 Expansion Panel
- Warranty Card
- Operator's Manual
- Release certification

Verify that all items are present before proceeding and report any shortage immediately to your supplier.

2.2.1 Warranty

Complete the warranty card information and send it to NAT when the installation is complete. If you fail to complete the warranty card, the warranty will be activated on date of shipment from NAT.

Note: An appropriately rated facility, e.g. Certified Aircraft Repair Station, must install this equipment in accordance with applicable regulations. NAT Ltd's warranty is not valid unless the equipment is installed by an authorized NAT Dealer. Failure to follow any of the installation instructions, or installation by a non-certified individual or agency will void the warranty, and may result in a non-airworthy installation.

2.3 Installation Procedures

2.3.1 Warnings

Do not bundle any lines from this unit with transmitter coax lines. Do not bundle any audio or DC power lines from this unit with 400 Hz synchro wiring or AC power lines. Do not position this unit or wiring from this unit next to any device with a strong alternating magnetic field such as an inverter, or significant audio interference will result.

2.3.2 Cautions

In all installations, use shielded cable exactly as shown and ground as indicated. Significant ground loop and noise problems may result from not following these guidelines.

The shielding and routing of the receive audio lines used in the AA30-301 installation is **very critical** and poor performance of the aircraft audio system will result if the installation shown on **Interconnect** drawing AA30\301\403-0 and -1 is not followed.

2.3.3 Cabling and Wiring

All unshielded wire shall be selected in accordance with AC43.13-1B Change 1, Paragraphs 11-76 through 11-78. Wire types should be to MIL-W-22759 as specified in AC43.13-1B Change 1, Paragraphs 11-85, 11-86, and listed in Table 11-11. For shielded wire applications, use Tefzel MIL-C-27500 shielded wire with solder sleeves (for shield terminations) to make the most compact and easily terminated interconnect. Follow the wiring diagrams in Section 2.6 as required.

Allow 3 inches from the end of the wire to the shield termination to allow the hood to be easily installed. Note that the hood is a 'clamshell' hood, and is installed after the wiring is complete.

All wiring should be at least 22 AWG, except power and ground lines, which should be at least 20 AWG. Ensure that all ground connections are clean and well secured.

2.3.4 Post-Installation Checks

2.3.4.1 Voltage/Resistance Checks

Check the following:

- a) P101 pin <13> for +28 Vdc avionics buss voltage.
- b) P101 pin <12> for +28 Vdc lighting buss voltage.
- c) P101 pins <15> <16> <18> <20> <22> and <25> for continuity to ground (power).
- d) P101 pin <24> for continuity to ground (lighting).

2.3.4.2 Power On Checks

WARNING:

**High volume settings can cause hearing damage.
Set the headset volume control to the minimum volume
setting prior to conducting audio tests, and slowly increase
the headset volume level to a comfortable listening level.**

- a) Install the AA30-301 and power up the aircraft's systems. Turn on the radios and accessories required for the system.
- b) Check for correct radio audio and adjust for acceptable level.
- c) Run through all installed functions, and check the RX and TX functions for all users. Refer to Section 3 for specific operation details.
- d) If any preset requires adjustment, be sure this is carried out before the aircraft leaves, and that the unit and its mating connector are secured before departure. Make all required log book entries, electrical load, weight and balance amendments and other paperwork as required by your local regulatory agency.

2.3.5 Adjustments

The unit is shipped from the factory with all internal adjustments set to the normal test levels. Once installed in the aircraft, it may be desirable to change some of these settings to best suit the local operating environment.

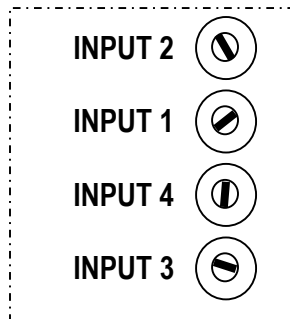

The gain of the COM RX inputs can be adjusted using potentiometers, accessible through holes in the top cover of the unit. Each hole is labelled to identify inputs 1 through 4 (see table).

COM RX Inputs	Label	Potentiometer
COM 1	INPUT 1	VR2
COM 2	INPUT 2	VR1
COM 3	INPUT 3	VR4
COM 4	INPUT 4	VR3

Upon satisfactory completion of all performance checks, make the required log entries and complete the necessary Regulatory Agency paperwork before releasing the aircraft for service.

2.4 Continued Airworthiness

Maintenance of the AA30-301 is 'on condition' only. Periodic maintenance of this product is not required.

2.5 Accessories Required But Not Supplied

Installation kit D25P25SL-IKC (Alt Part No AA12-IKC) is required to complete the installation. The kit consists of the following:

One D25SL-IKC 25 Pin D-min Female Crimp Kit

Quantity	Description	NAT Part #
1	D-min 25 Socket Housing	20-21-025
25	MS Crimp Socket	20-26-901
1*	Jack Screw Set	20-27-002
1*	Lock Clip Set	20-27-004
1	25 Pin Connector Hood	20-29-026

One D25PL-IKC 25 Pin D-min Male Crimp Kit

Quantity	Description	NAT Part #
1	D-min 25 Pin Housing	20-11-025
25	MS Crimp Pin	20-26-891
1*	Jack Screw Set	20-27-002
1*	Lock Clip Set	20-27-004
1	25 Pin Connector Hood	20-29-026

* Use as required.

2.6 Installation Drawings

DRAWING	REV.	DESCRIPTION	TYPE	SERIAL #
AA30\301\403-0	1.11	Expansion Panel	Interconnect	All
AA30\301\403-1	1.11	Expansion Panel	Interconnect	All
AA30\301\405-0	1.00	Expansion Panel	Connector Map	All
AA30\301\521-0	1.00	Expansion Panel	Environmental Qual Form	3001 and up
AA30\301\905-0	1.00	Expansion Panel	Faceplate	All
AA30\301\922-0	1.00	Expansion Panel	Mech. Installation	1224-1260
AA30\301\922-0	1.10	Expansion Panel	Mech. Installation	1261 - 1268
AA30\301\922-0	1.20	Expansion Panel	Mech. Installation	1269 - 1282
AA30\301\922-0	1.30	Expansion Panel	Mech. Installation	1283 - 3000
AA30\301\922-0	1.31	Expansion Panel	Mech. Installation	3001 and up

Section 2 ends after these Drawings

REVISIONS			
REV	DESCRIPTION	DATE	BY
1.10	DOCCR01415 - CHANGED NOTE 2 AND SHIELD CONNECTIONS.	NOV 1/05	TAT
1.11	DOCCR01797 - CORRECTED CONNECTIONS TO 380.	SEP 26/06	TAT

AA30-301 INSTALLATION NOTES

NOTES:

- ALL WIRES SHOULD BE 22 AWG UNLESS OTHERWISE SPECIFIED. ALL UNSHIELDED WIRE SHALL BE SELECTED IN ACCORDANCE WITH AC43.13-1B CHANGE 1, PARAGRAPHS 11-76 THROUGH 11-78. WIRE TYPES SHOULD BE TO MIL-W-22759 AS SPECIFIED IN AC43.13-1B CHANGE 1, PARAGRAPHS 11-85, 11-86 AND LISTED IN TABLE 11-11. ALL SHIELDED WIRE/CABLE SHOULD BE IN ACCORDANCE WITH MIL-C-27500.



GROUND AS SHOWN FOR OPTIMAL CROSSTALK AND EMI/RFI PERFORMANCE.

DEFINITIONS:

RESERVED: MAY BE CONNECTED AND USED IN THE FUTURE. THE CIRCUITRY MAY BE PRESENT OR ADDED TO ACTIVATE THE FUNCTION. THE PIN MAY BE USED FOR TEST PURPOSES. THERE IS NO EXTERNAL CONNECTION.

CONFIDENTIAL AND PROPRIETARY TO NAT LTD.

DESIGNED	KEH	 NAT NORTHERN AIRBORNE TECHNOLOGY LTD.				
DRAWN	MWS					
DATE	MAR 08/05	TITLE				EXPANSION PANEL
CHECKED	NAT 249					
APPROVED	NAT 500	SIZE	CAGE CODE	PART NO.	REV.	SHEET
		A	3AB01	AA30-301	1.11	1/2
FILE	403-0.DWG	DWG. TYPE	INTERCONNECT	DWG. NO.	AA30\301\403-0	

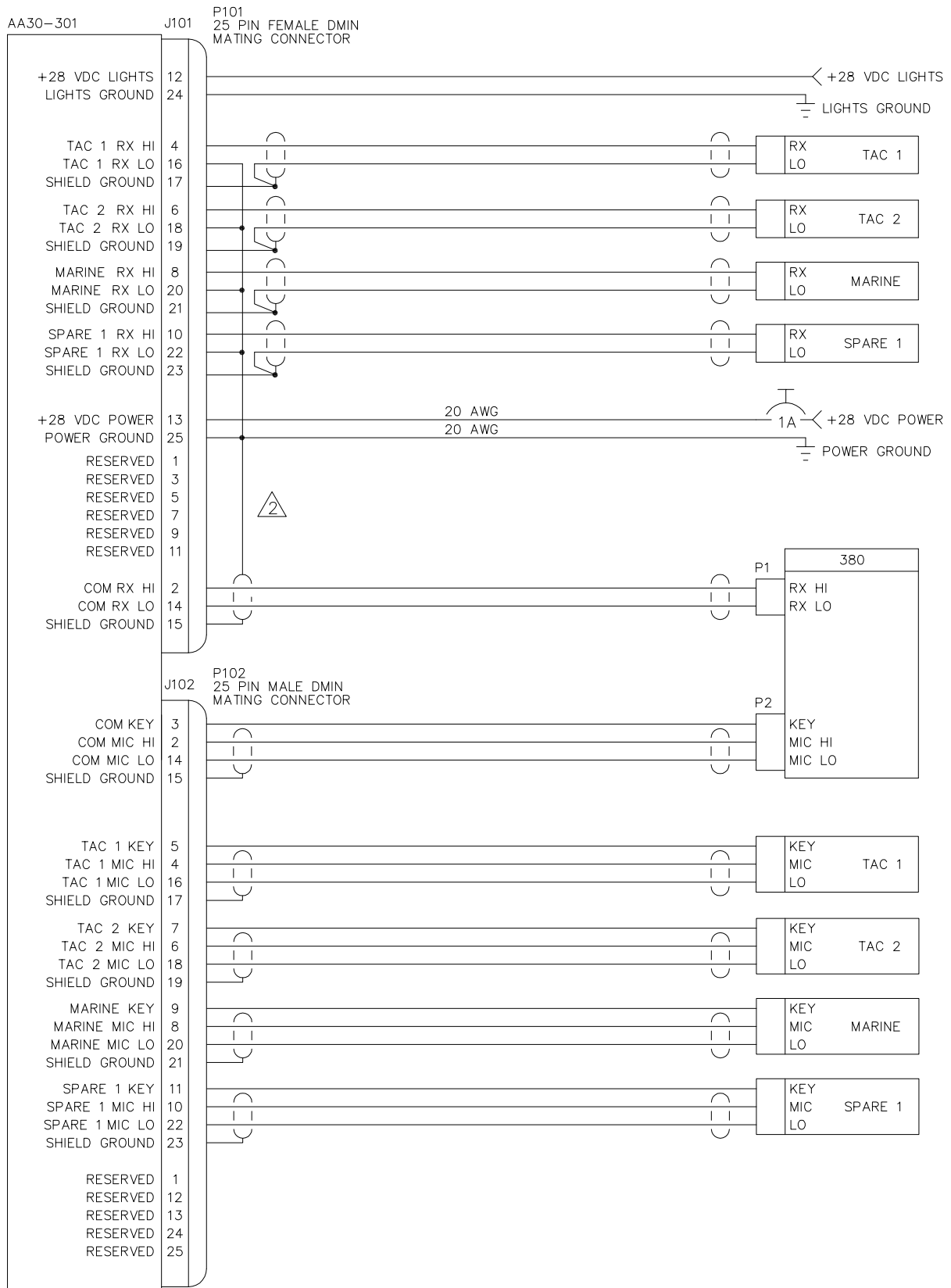

CONFIDENTIAL AND PROPRIETARY TO NAT LTD.

DESIGNED	KEH	NAT NORTHERN AIRBORNE TECHNOLOGY LTD.				
DRAWN	MWS					
DATE	MAR 08/05	TITLE				
CHECKED	NAT 249	EXPANSION PANEL				
APPROVED	NAT 500	SIZE	CAGE CODE	PART NO.	REV.	SHEET
		A	3AB01	AA30-301	1.11	2/2
FILE	403-0.DWG	DWG. TYPE	INTERCONNECT	DWG. NO.	AA30\301\403-1	

P101

25 PIN FEMALE D-MIN
MATING CONNECTOR

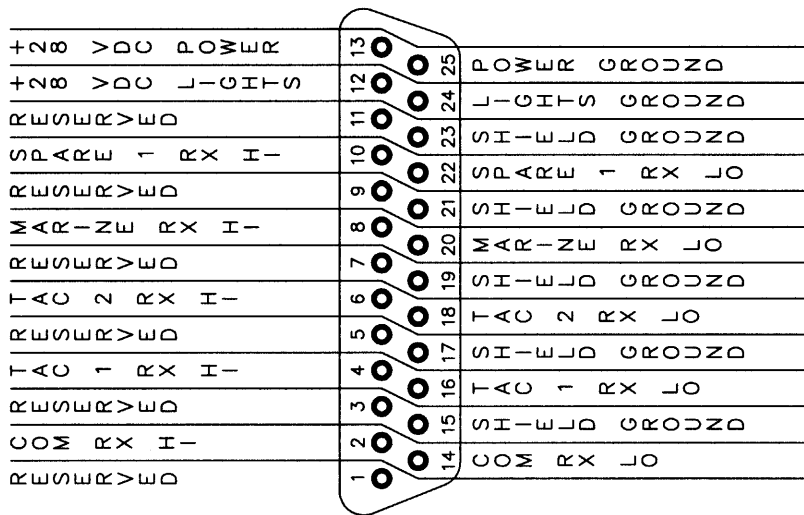

VIEW IS FROM REAR OF AIRFRAME CONNECTOR

P102

25 PIN MALE D-MIN
MATING CONNECTOR

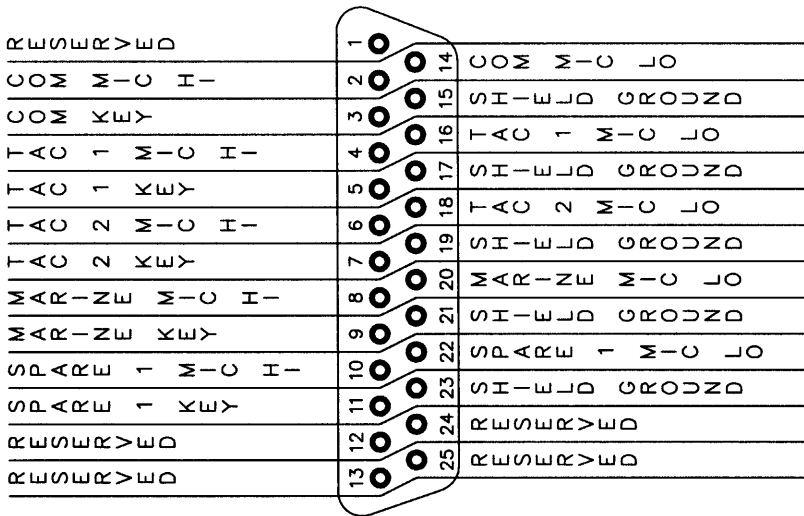

VIEW IS FROM REAR OF AIRFRAME CONNECTOR

CONFIDENTIAL AND PROPRIETARY TO NAT LTD.

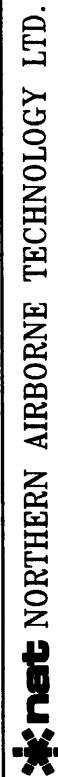

DESIGNED	KWH	TITLE		EXPANSION PANEL	REV.	SHEET
DRAWN	MWS				1.00	1/1
DATE	FEB 24/05					
CHECKED	NAT 201					
	NAT 255					
APPROVED	(NAT 114)	SIZE	CAGE CODE	PART NO.		
		A	3AB01	AA30-301		
FILE	405-0.DWG	DWG. TYPE	CONNECTOR MAP	DWG. NO.	AA30\301\405-0	



ENVIRONMENTAL QUALIFICATION FORM

Description: Expansion Panel Document #: AA30\3xx\521-0

NAT Part #: AA30-3xx TSO #: C139

Manufacturer's Specification and/or Other Applicable Specification: RTCA/DO-160E

Manufacturer: Northern Airborne Technology Ltd.

Address: 1925 Kirschner Rd., Kelowna, BC, Canada. V1Y 4N7

Prepared By:

DE
05

Checked By:

NAT
220

Approved By:

NAT
125

Conditions	Section	Description of Conducted Tests
Temperature and Altitude	4.0	Equipment tested to Category [(A2)(F2)-].
Low Temperature	4.5.1 & 4.5.2	<ul style="list-style-type: none"> -55° C Operating Low Temperature & Short-Time Operating Low Temperature. +70° C Operating High Temperature & Short-Time Operating High Temperature. N/A. No forced air cooling.
High Temperature	4.5.3 & 4.5.4	
In-flight Loss of Cooling	4.5.5	
Altitude	4.6.1	
Decompression	4.6.2	<ul style="list-style-type: none"> +55,000 ft (+16,764 m). +8,000 ft (+2,438 m) to +55,000 ft (+16,764 m). -15,000 ft (-4,572 m).
Overpressure	4.6.3	
Temperature Variation	5.0	Equipment tested to Category B.
Humidity	6.0	Equipment tested to Category A.
Shock	7.0	Equipment tested to Category B. Performance requirements were tested subsequent to Operational Shock test.
Operational	7.2.2	<ul style="list-style-type: none"> Alternate Test Procedure Alternate Test Procedure (Impulse). Test Procedure 2 (Sustained), Unknown or Random orientation in aircraft.
Crash Safety	7.3.2	
	7.3.3	

Conditions	Section	Description of Conducted Tests
Vibration	8.0	Equipment tested to Category [(RBB1)(SM)] (without shock mounts). <ul style="list-style-type: none"> The equipment was also tested to vibration profile F (one hour per axis) per DO-160E sub-paragraph 8.3.3 a) and met the minimum performance standard.
Explosion	9.0	Equipment identified as Category X no test required.
Waterproofness	10.0	Equipment identified as Category X no test required.
Fluids Susceptibility	11.0	Equipment identified as Category X no test required.
Sand and Dust	12.0	Equipment identified as Category X no test required.
Fungus	13.0	Equipment identified as Category X no test required.
Salt Spray	14.0	Equipment identified as Category X no test required.
Magnetic Effect	15.0	Equipment is Class Z.
Power Input	16.0	Equipment tested to Category Z. <ul style="list-style-type: none"> Equipment was tested to subparagraph 16.6.1.3 b, requirement for digital circuits. Emergency Operating Voltage was tested.
Voltage Spike	17.0	Equipment tested to Category A
Audio Frequency Susceptibility	18.0	Equipment tested to Category Z
Induced Signal Susceptibility	19.0	Equipment tested to Category [AC]

Conditions	Section	Description of Conducted Tests
Radio Frequency Susceptibility	20.0	Equipment tested to Category [TT] <ul style="list-style-type: none"> Sub-paragraph 20.5 Radiated Susceptibility was tested per DO-214 section 2.5.11 and DO-160E
Radio Frequency Emission	21.0	Equipment tested to Category M
Lightning Induced Transient Susceptibility	22.0	Equipment tested to Category [XXC1X]
Lightning Direct Effects test	23.0	Equipment identified as Category X no test required
Icing	24.0	Equipment identified as Category X no test required
ESD	25.0	Equipment identified as Category X no test required
Fire, Flammability	26.0	Equipment identified as Category X no test required.
Other Test		Fire resistance tests on the faceplate material were conducted in accordance with Federal Aviation Regulations Part 25, Appendix F



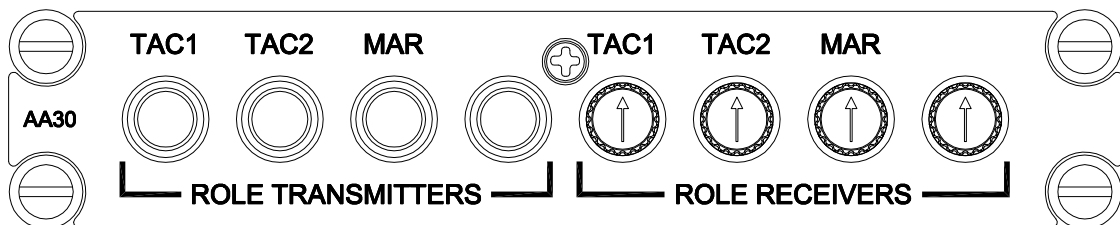

REMARKS

- DO-160E, Sections 4 to 8, and 15 to 22 tests were conducted at Northern Airborne Technology Ltd. (NAT) in Kelowna, BC on model AA30-301.
- Fire resistance tests were performed at Bodycote Materials Testing Canada Inc in Mississauga, ON on a sample of faceplate material.

End of Environmental Qualification Form



CONFIDENTIAL AND PROPRIETARY TO NAT LTD.

DESIGNED	KEH	 NAT NORTHERN AIRBORNE TECHNOLOGY LTD.				
DRAWN	MWS					
DATE	MAR 03 / 05	TITLE	EXPANSION PANEL			
CHECKED	 					
APPROVED		SIZE	CAGE CODE	PART NO.	REV.	SHEET
FILE	905-0.DWG	A	3AB01	AA30-301	1.00	1/1
DWG. TYPE		FACEPLATE		DWG. NO. AA30\301\905-0		

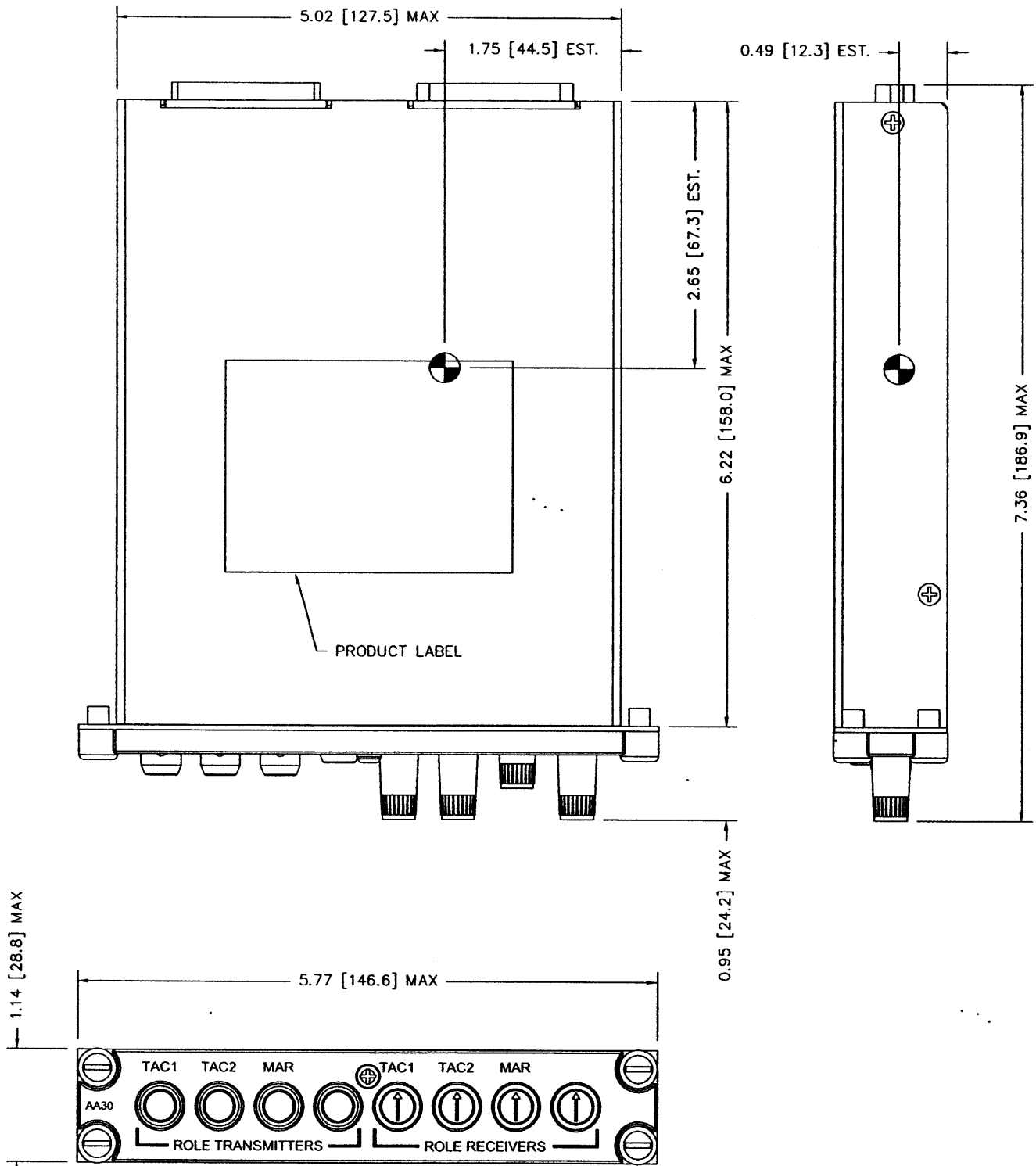

NOTES:
 1. DIMENSIONING AND TOLERANCING
 IN ACCORDANCE WITH ASME Y14.5M-1994

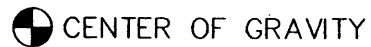

CONFIDENTIAL AND PROPRIETARY TO NAT LTD.

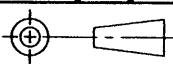
DIMENSIONS ARE INCHES [mm]		DESIGNED	KEH	 nat NORTHERN AIRBORNE TECHNOLOGY LTD.				
THIRD ANGLE PROJECTION 		DRAWN	MWS					
MASS: 1.0 lbs. (0.455 kg)		DATE	FEB 23/05	TITLE				
MATERIAL:		CHECKED	NAT 201	EXPANSION PANEL				
FINISH:		APPROVED	NAT 117	SIZE	CAGE CODE	PART NO.	REV.	SHEET
		FILE	922-0.DWG	A	3AB01	AA30-301	1.00	1/1
				DWG. TYPE	MECH. INSTALLATION	DWG. NO.	AA30\301\922-0	

REVISIONS			
REV	DESCRIPTION	DATE	BY
1.01	DOCCR01201 - MASS WAS 1.0 LBS. (0.455 KG).	APR 13/05	TAT
1.10	DOCCR01296 - CHANGES TO TOP COVER	JUL 21/05	MWS

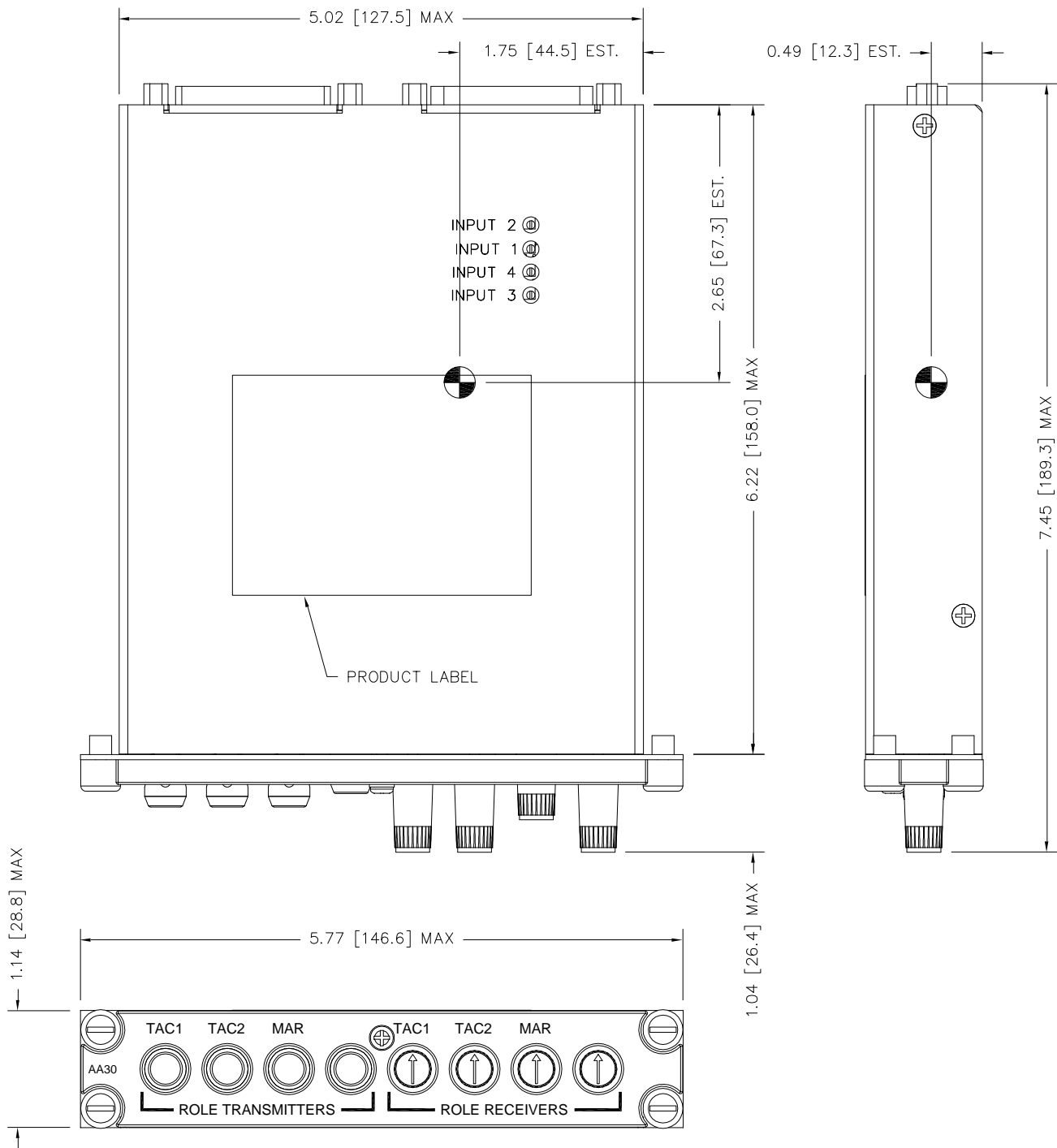

NOTES:
 1. DIMENSIONING AND TOLERANCING
 IN ACCORDANCE WITH ASME Y14.5M-1994



CONFIDENTIAL AND PROPRIETARY TO NAT LTD.

DIMENSIONS ARE INCHES [mm]	DESIGNED	KEH		NAT NORTHERN AIRBORNE TECHNOLOGY LTD.				
	DRAWN	MWS						
THIRD ANGLE PROJECTION	DATE	FEB 23/05		TITLE				
MASS: 1.05 lbs. (0.476 kg) MAX	CHECKED	NAT 201	NAT 255	EXPANSION PANEL				
MATERIAL:	APPROVED			SIZE	CAGE CODE	PART NO.	REV.	SHEET
FINISH:	FILE	922-0.DWG		A	3AB01	AA30-301	1.10	1/1
				DWG. TYPE	MECH. INSTALLATION	DWG. NO.	AA30\301\922-0	

REVISIONS			
REV	DESCRIPTION	DATE	BY
1.01	DOCCR01201 - MASS WAS 1.0 LBS. (0.455 KG).	APR 13/05	TAT
1.10	DOCCR01296 - CHANGES TO TOP COVER	JUL 21/05	MWS
1.20	DOCCR01415 - CHANGED CHASSIS AND COVER.	NOV 1/05	TAT

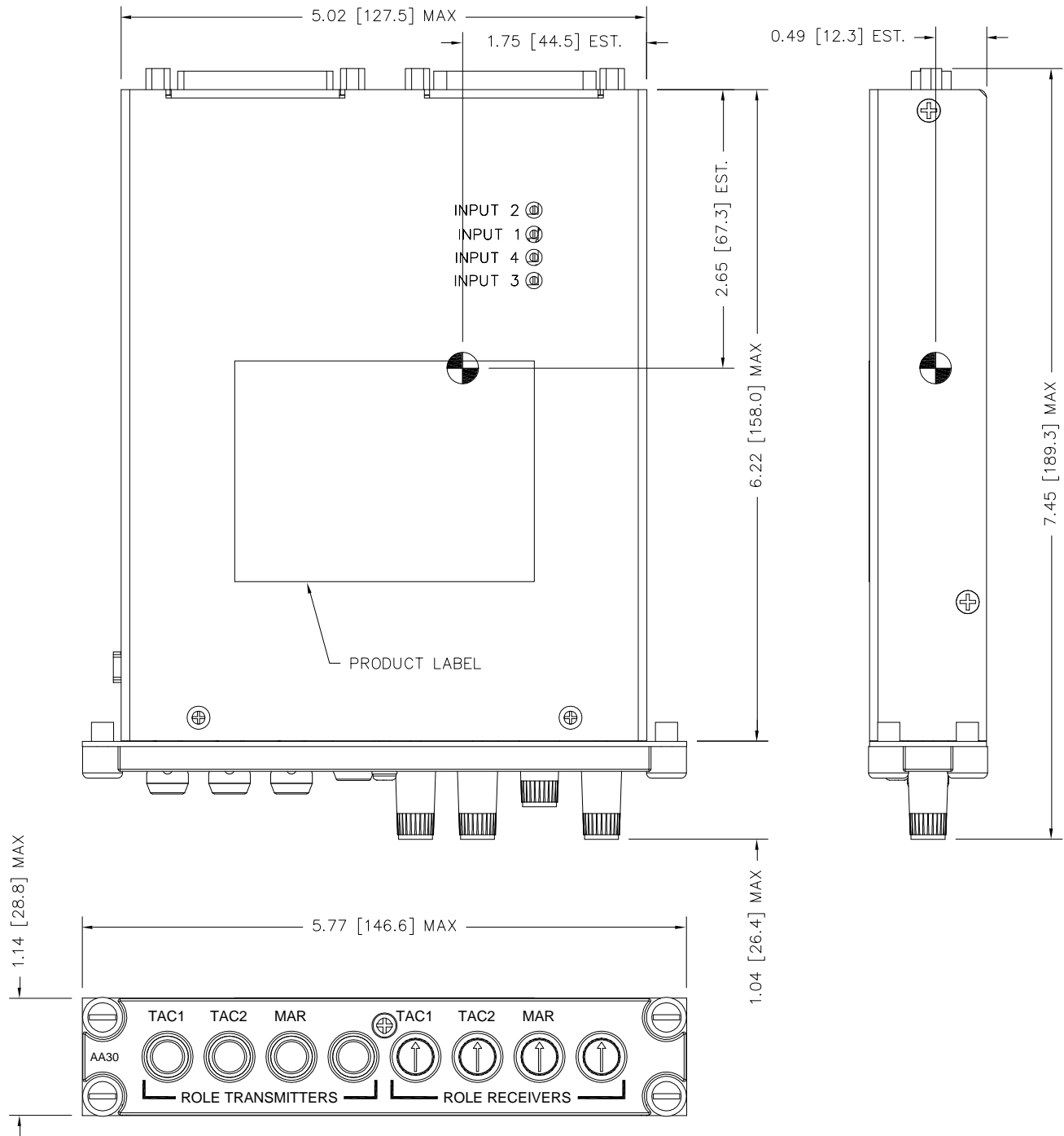

NOTES:
 1. DIMENSIONING AND TOLERANCING
 IN ACCORDANCE WITH ASME Y14.5M-1994

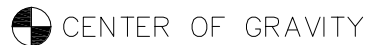

CONFIDENTIAL AND PROPRIETARY TO NAT LTD.

DIMENSIONS ARE INCHES [mm]	DESIGNED	KEH	NORTHERN AIRBORNE TECHNOLOGY LTD.				
	DRAWN	MWS					
THIRD ANGLE PROJECTION	DATE	FEB 23/05	TITLE				
MASS: 1.05 lbs. (0.476 kg) MAX	CHECKED	NAT 255	EXPANSION PANEL				
MATERIAL:	APPROVED	NAT 131	SIZE	CAGE CODE	PART NO.	REV.	SHEET
FINISH:	FILE	922-0.DWG	A	3AB01	AA30-301	1.20	1/1
			DWG. TYPE	MECH. INSTALLATION	DWG. NO.	AA30\301\922-0	

REVISIONS			
REV	DESCRIPTION	DATE	BY
1.01	DOCCR01201 – MASS WAS 1.0 LBS. (0.455 KG).	APR 13/05	TAT
1.10	DOCCR01296 – CHANGES TO TOP COVER.	JUL 21/05	MWS
1.20	DOCCR01415 – CHANGED CHASSIS AND COVER.	NOV 1/05	TAT
1.30	DOCCR01716 – ADDED FRONT PLATE; CHANGED CHASSIS, COVER AND C OF G; MASS WAS 1.05 lbs. (0.476 kg) MAX.	AUG 14/06	MWS

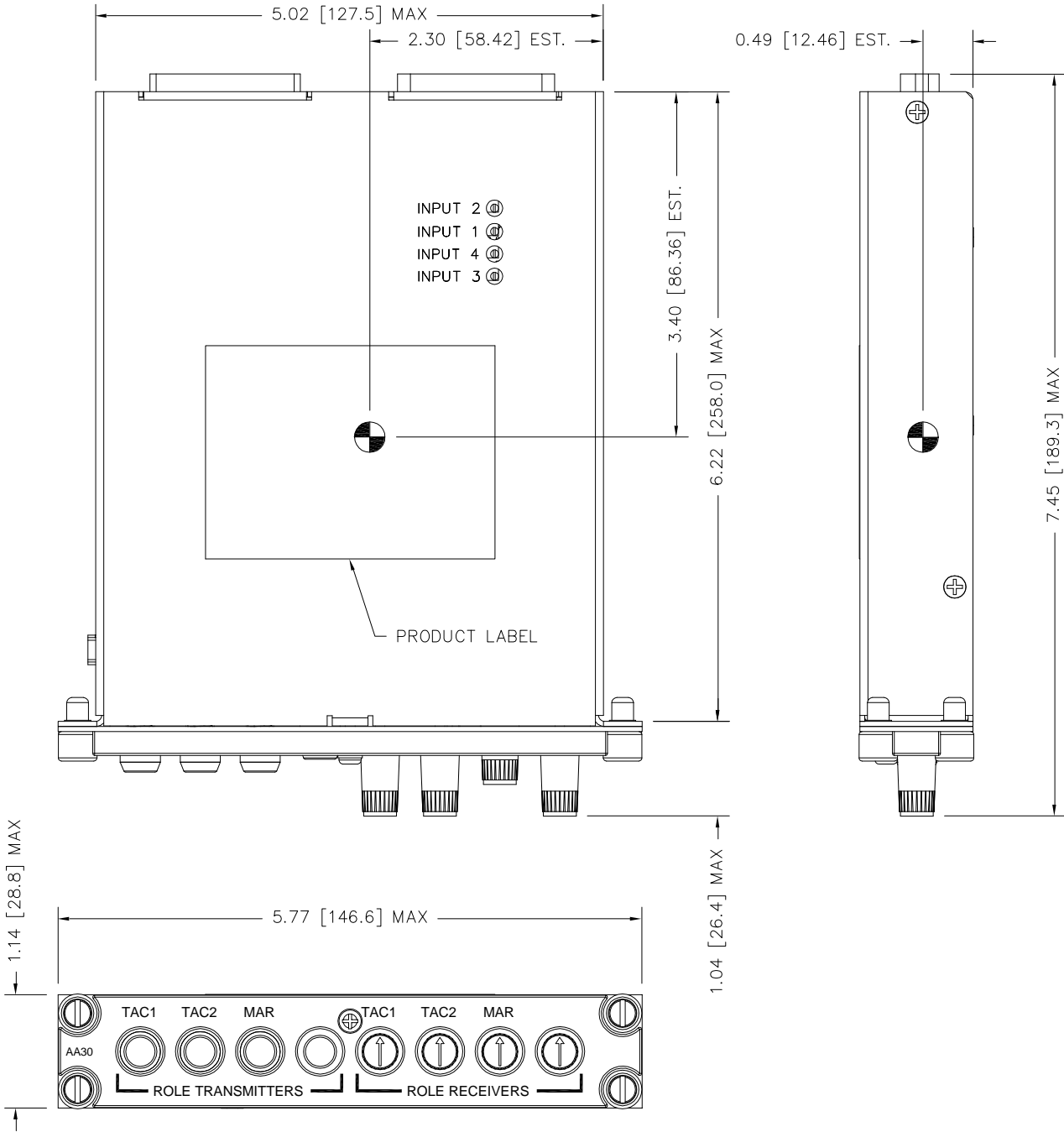

NOTES:
1. DIMENSIONING AND TOLERANCING
IN ACCORDANCE WITH ASME Y14.5M-1994

CENTER OF GRAVITY

CONFIDENTIAL AND PROPRIETARY TO NAT LTD.

TOLERANCES UNLESS STATED OTHERWISE 0.X=+/-0.030 0.XX=+/-0.010 0.XXX=+/-0.005 0.XXXX=+/-0.002 ANGLE=+/- 0.5 DEG.	DIMENSIONS IN INCHES	DESIGNED	KEH	NAT NORTHERN AIRBORNE TECHNOLOGY LTD.				
	THIRD ANGLE PROJECTION	DRAWN	MWS					
		DATE	FEB 23/05	TITLE				
		CHECKED		EXPANSION PANEL				
MASS: 1.15 lbs. (0.504 kg)		APPROVED		SIZE	CAGE CODE	PART NO.	REV.	SHEET
MATERIAL: -				A	3AB01	AA30-301	1.30	1/1
FINISH: -		FILE	922-0.DWG	DWG. TYPE	MECH. INSTALLATION	DWG. NO.	AA30\301\922-0	

REVISIONS			
REV	DESCRIPTION	DATE	BY
1.01	DOCCR01201 – MASS WAS 1.0 LBS. (0.455 KG).	APR 13/05	TAT
1.10	DOCCR01296 – CHANGES TO TOP COVER.	JUL 21/05	MWS
1.20	DOCCR01415 – CHANGED CHASSIS AND COVER.	NOV 1/05	TAT
1.30	DOCCR01716 – ADDED FRONT PLATE; CHANGED CHASSIS, COVER AND C OF G; MASS WAS 1.05 lbs. (0.476 kg) MAX.	AUG 14/06	MWS
1.31	DOCCR01787 – CORRECTED LENGTH AND MASS.	SEP 27/06	MWS

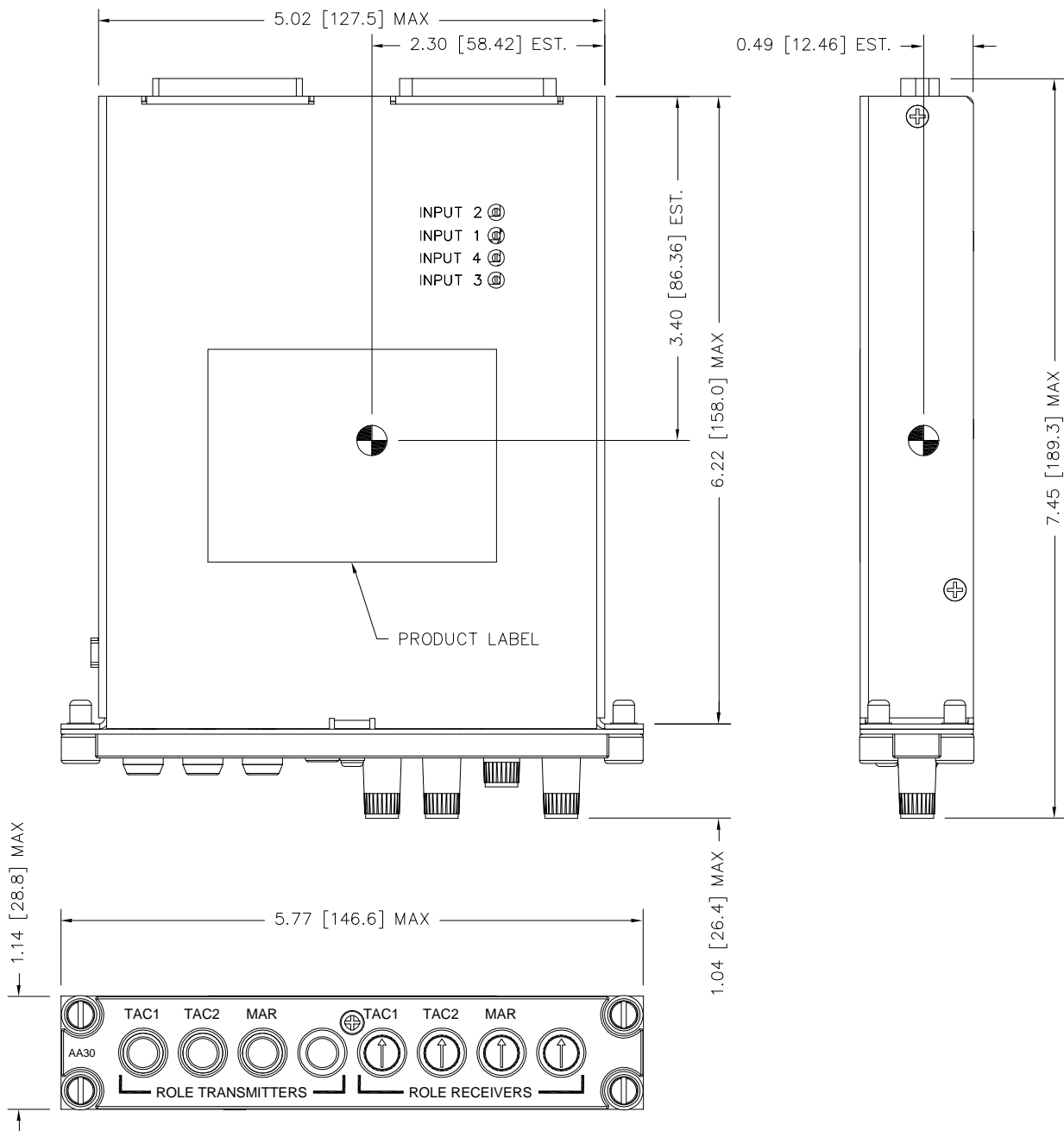

NOTES:
 1. DIMENSIONING AND TOLERANCING
 IN ACCORDANCE WITH ASME Y14.5M-1994



CONFIDENTIAL AND PROPRIETARY TO NAT LTD.

TOLERANCES UNLESS STATED OTHERWISE 0.X=+/-0.030 0.XX=+/-0.010 0.XXX=+/-0.005 0.XXXX=+/-0.002 ANGLE=+/- 0.5 DEG.	DIMENSIONS IN INCHES	DESIGNED	KEH	NAT NORTHERN AIRBORNE TECHNOLOGY LTD.				
	THIRD ANGLE PROJECTION	DRAWN	MWS					
		DATE	FEB 23/05	TITLE				
		CHECKED	NAT 249	EXPANSION PANEL				
MASS: 1.15 lbs. (0.522 kg) MAX		APPROVED	NAT 500	SIZE	CAGE CODE	PART NO.	REV.	SHEET
MATERIAL: -				A	3AB01	AA30-301	1.31	1/1
FINISH: -		FILE	922-0.DWG	DWG. TYPE	MECH. INSTALLATION	DWG. NO.	AA30\301\922-0	

Section 3 Operation

3.1 Introduction

Information in this section consists of the functional and operational procedures for the AA30-301 Expansion Panel.

3.2 General

The AA30-301 Expansion Panel is a Dzus-mounted 4-transceiver or radio receiver expansion panel, designed to work in conjunction with the 380-series Audio Selector Panels.

3.3 Controls and Indicators

The AA30-301 provides four ganged transmitter selector pushbutton switches and four receiver level panel potentiometers, each with an integral push-in / push-out selector switch.

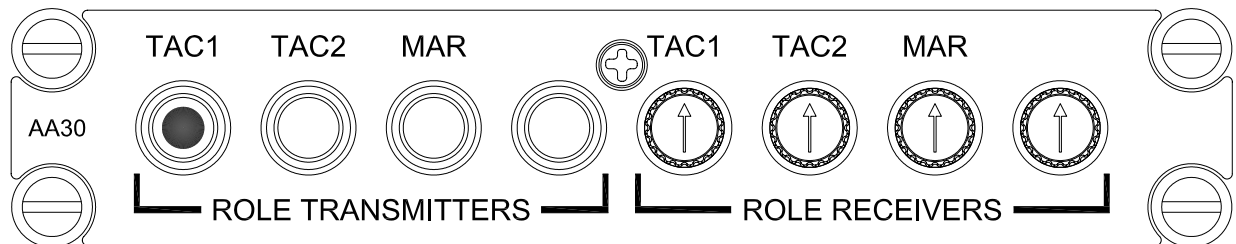

The laser-engraved text of the faceplate and any selected transmitter or receiver control is illuminated when backlighting power is supplied to the unit.

3.3.1 Transmitter Selection

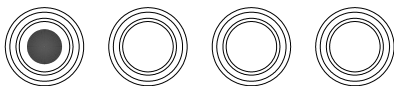

The transmitter control switches are four push switches that are used to select transceivers for transmission.

When the transmitter control switch is the extended (out) position, the corresponding transmitter is deselected (off), and the integral mechanical annunciator appears black behind the clear window, and when the transmitter control switch is in the depressed (in) position, the corresponding transmitter is selected (on), and the integral mechanical annunciator appears green behind the clear window.

The default position for all transmitters is deselected (out).

The transmitter controls are designed to prevent accidental selection of more than one transmitter; pushing a transmitter control switch locks it into the depressed (in) position and cancels any previously selected transmitter control by returning it to the extended position.

All transmitters may be deselected by partially depressing any unselected transmitter control.

When a transmitter is selected, the mic key and mic audio signals are automatically directed to that transmitter.

A selected transmitter control bypasses the corresponding receiver control selector switch (see section 3.3.2) to provide an auto-receive function.

3.3.2 Receiver Selection

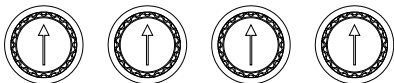

The receiver control switches are four push-on/push-off rotary switches that are used to select receivers and adjust volumes.

3.3.2.1 Selection

When the receiver control switch is in the default depressed (in) position, the corresponding receiver is deselected (off), and when the receiver control switch is in the extended (out) position, the corresponding receiver is selected (on).

The default position for all receivers is deselected (in).

The auto-receive function automatically selects a receiver for audio when the corresponding transmitter control is depressed, even if the receiver control is not in the selected position.

Receiver controls are independent; any combination of receivers may be simultaneously selected.

3.3.2.2 Volume Control

The volume for each receiver can be adjusted by rotating the corresponding control. The receiver volume is decreased to minimum at the full counterclockwise (ccw) stop, and increased to maximum at the full clockwise (cw) stop.

If a receiver is activated by the Auto-receive function, the level is set by the current receiver volume control, even if the control is deselected.

End of section 3