

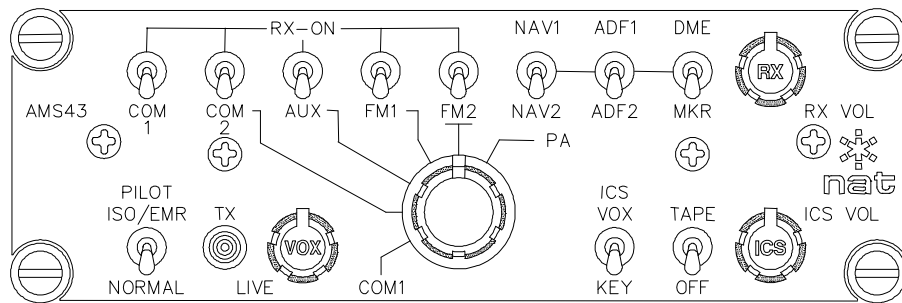

# Installation and Operation Manual

## AMS43 Single Channel Audio Controller



**SM59**

**ISSUE 4.01**

Northern Airborne Technology Ltd.  
1925 Kirschner Road  
Kelowna, BC, Canada.  
V1Y 4N7  
Telephone (250) 763-2232  
Facsimile (250) 762-3374

Issued on the authority of Northern Airborne Technology Ltd.

Copyright 2003



**AMS43 Single Channel Audio Controller  
SM59 Installation and Operation Manual**

---

**IMPORTANT INFORMATION**

This manual has been produced to provide information unique to the AMS43 Single Channel Audio Controller. Some of this information has been published previously in the SM01 Service manual (AA90/AMS40 Series Audio Controllers).

Earlier versions of the AMS43 may not be covered by the information in this manual. Please refer to SM01, or contact the Technical Support Department at NAT Ltd.





**AMS43 Single Channel Audio Controller  
SM59 Installation and Operation Manual**

---

**Table of Contents**

<b>Section</b>	<b>Title</b>	<b>Page</b>
<b>1.</b>	<b>Description</b>	
1.1	Introduction	1-1
1.2	Product Description	1-1
1.3	Design Features	1-1
1.4	Specifications	1-2
1.4.1	Electrical Specifications	1-2
1.4.2	Physical Specifications	1-3
1.4.3	Environmental Specifications	1-3
<b>2.</b>	<b>Installation</b>	
2.1	Introduction	2-1
2.2	Unpacking and Inspection	2-1
2.2.1	Warranty	2-1
2.3	Continued Airworthiness	2-1
2.4	Installation Procedures	2-1
2.4.1	Warnings	2-1
2.4.2	Cautions	2-2
2.4.3	Cabling and Wiring	2-2
2.4.4	Post Installation Checks	2-2
2.5	Adjustments and Connections	2-3
2.5.1	Left Side panel adjustments	2-4
2.5.2	Right Side Panel Adjustments	2-4
2.5.3	In-line PTT Drop Cords	2-4
2.6	Accessories Required But Not Supplied	2-6
2.7	Installation Drawings	2-7
<b>3.</b>	<b>Operation</b>	
3.1	Introduction	3-1
3.2	General Information	3-1
3.3	Controls and Indicators	3-1
3.3.1	Receive Audio Select Switches	3-1
3.3.2	Transmit Selector Switch	3-2
3.3.3	ICS Functions	3-3
3.4	Emergency Operation	3-4
3.5	Audio Alerting Functions	3-4
3.5.1	Direct Audio	3-4
3.5.2	Internal Alerting	3-4



# AMS43 Single Channel Audio Controller SM59 Installation and Operation Manual

---

## Section 1 Description

---

### 1.1 Introduction

---

Information in this section consists of product description, design features and specifications for the AMS43 Single Channel Audio Controller. All derivative product information shall be contained in the applicable manual supplement, which may be obtained from NAT as required.

Review all notes, warnings and cautions.

### 1.2 Product Description

---

The AMS43 provides control of aircraft audio, allowing selection of transmit (TX) and receive (RX) audio, LIVE, KEYED, or voice activated (VOX) intercom, interface for an additional hand-held transmit microphone (hand mic), and pilot isolation/emergency (ISO/EMR) operation.

TX and PA functions are controlled with a single rotary switch. RX audio, intercom (ICS) operations and tape audio are controlled with toggle switches. RX volume, ICS volume and ICS VOX squelch are individually adjusted with rotary controls. Sidetone (S/T) level is adjustable internally.

### 1.3 Design Features

---

The AMS43 is a Dzus rail mounted unit with a backlit faceplate. Transceiver interfacing is accomplished through directly switched microphones. To ensure maximum radio compatibility, it has a ground-referenced keyline that does not incorporate diodes or other steering components.

Independent control is provided for S/T, ICS audio, and RX audio.

Boom mic support is provided for the pilot and co-pilot, with both ICS and TX functions via cyclic or yoke switching. Live (Hot Mic) and VOX ICS allow immediate transmission without additional control panel switching, with immediate return to ICS operation on completion. The ICS function is achieved using dynamic noise reduction and active filtering. This provides the clearest possible ICS audio under high ambient noise conditions by rejecting airframe and wind noise, and passing only voiceband information.

All audio, except the S/T of the radio in use and DIRECT AUDIO 2 input signals, is muted during TX for clarity. ICS operation allows TX during any ICS mode by using the TX push-to-talk (PTT) switch.

All external interconnect, switches and relay contacts are gold plated for maximum reliability. Switches and relays are sealed. G10-FR flame-retardant circuit boards are postcoated for maximum moisture resistance and corrosion prevention.

Relays are sealed, high vibration rated (50g shock), dry nitrogen filled units.



## AMS43 Single Channel Audio Controller SM59 Installation and Operation Manual

---

### 1.4 Specifications

---

#### 1.4.1 Electrical Specifications

---

Input Power	27.5 Vdc Nominal 0.50 A Max.
Lighting	27.5 Vdc @ 160 mA
Alert Power	27.5 Vdc Nominal 150 mA Max.
Input Signals:	
Quantity	13 receive channels 7 mic channels 1 ICS tie channel 2 direct channels
Audio level	2.5 Vrms for receiver inputs 0.25 Vrms for mic inputs 0.34 Vrms for ICS tie input 2.5 Vrms for direct audio inputs
Impedance	1 k $\Omega$ $\pm$ 10% for receive inputs 1 k $\Omega$ $\pm$ 10% for mic inputs 1.8 k $\Omega$ $\pm$ 10% for ICS tie input 1.3 k $\Omega$ $\pm$ 10% for Direct Audio1 input 100 $\Omega$ $\pm$ 10% for Direct Audio 2 input
Circuitry Type	All are single ended inputs.
Coupling	<-50 dB
Key lines	Pilot & copilot transmit PTT Rear hand mic transmit PTT Pilot & copilot ICS PTT 3 Alerts - active low
Output Signals:	
Quantity	6 Headset outputs 6 Transmitter mic outputs 5 Transmitter keyline outputs
Rated level:	
Headset	7.7 Vrms or 100 mW (20 dBm) into 600 $\Omega$
Direct Audio1	10 mW (10 dBm) into 600 $\Omega$
Direct Audio 2	0.1 mW (-10 dBm) 0.25 Vrms into 600 $\Omega$
Alert	90 mVrms $\pm$ 10% into 600 $\Omega$
Impedance	65 $\Omega$ Max
Circuitry Type	Single-ended, except for phones, which are balanced.
Freq. Response:	
Sidetone	<3 dB from 650 Hz to 1750 Hz
Receive inputs	<3 dB from 500 Hz to 2200 Hz



## AMS43 Single Channel Audio Controller SM59 Installation and Operation Manual

---

Intercom	<3 dB from 550 Hz to 2400 Hz
Alert 1	1.5 kHz $\pm$ 20%
Alert 2	Same as Alert 1 but swept @ 2 cycles/sec
Alert 3	Approx. same as Alert 2 but on for 2 sec
Distortion	<10% THD @ rated power output
Audio Noise Level	>50 dB down from rated output (no signal)
Coupling	<-50 dB
Output Regulation at 400% and 75% of rated load.	<10% distortion and <3 dB max of rated output power
Annunciators	Green LED will light for transmit operation

### 1.4.2 Physical Specifications

---

Height	1.90 inches (48.3 mm)
Depth	6.82 inches (173.2 mm)
Width (behind panel)	5.00 inches (127.0 mm)
Weight	2.1 lbs. (955 g)
Mounting	Dzus rail
Faceplate	Engraved acrylic edge lit panel
Material/Finish	Chassis & cover are 5052-H32 brushed aluminum with chromate conversion finish
Connectors	Male 50 pin & 37 pin D-submin connectors with slide locks

### 1.4.3 Environmental Specifications

---

DO-160C Env. Cat.	B1-CANXXXXXXABABBBBXXX
Operating Temperatures	-20 °C to +55 °C
Survival Temperatures	-55 °C to +85 °C
Vibration/Shock	DO-160C Cat. N
Humidity	95%
Altitude	25,000 ft. Max

**Section 1 ends**

---



## AMS43 Single Channel Audio Controller SM59 Installation and Operation Manual

---

### Section 2 Installation

---

#### 2.1 Introduction

---

Information in this section consists of unpacking and inspection procedures, installation procedures, post-installation checks and installation drawings for the AMS43 Single Channel Audio Controller.

Review all notes, warnings and cautions.

#### 2.2 Unpacking and Inspection

---

Unpack the equipment carefully and locate the warranty card. Inspect the unit visually for damage due to shipping and report all such claims immediately to the carrier involved. Check that all items listed below are present before proceeding and report any shortage immediately to your supplier:

- Warranty Card
- Operators Manual
- Certificate of Conformity or Release Certification

##### 2.2.1 Warranty

---

All Northern Airborne Technology Ltd. products are warranted for 2 years from date of installation by an authorized NAT dealer, to be free of defects in workmanship or performance. This warranty covers all materials and labour, but is exclusive of any transport to deliver the defective unit to and from NAT or its designated warranty repair center, or any labour to remove or re-install the defective unit in the aircraft. Contact NAT for any questions regarding this warranty, its applicability to your units and/or for return authorization. NAT is the final arbitrator concerning warranty administration. Units which have been physically damaged, burned, immersed in water or otherwise abused beyond the scope of normal use will not be considered for warranty. **WARRANTY IS VOID UNLESS THE PRODUCT IS INSTALLED BY AN AUTHORIZED NAT DEALER.** Product for which a warranty card is not returned shall be warranted from date of manufacture.

#### 2.3 Continued Airworthiness

---

Maintenance of the AMS43 Single Channel Audio Controller is 'on condition' only. Periodic maintenance of this product is not required.

#### 2.4 Installation Procedures

---

##### 2.4.1 Warnings

---

<p style="text-align: center;"><b>WARNING:</b> High volume settings can cause hearing damage. Set the headset volume control to the minimum volume setting prior to conducting tests, and slowly increase the headset volume to a comfortable listening level.</p>
--



## AMS43 Single Channel Audio Controller SM59 Installation and Operation Manual

---

### 2.4.2 Cautions

---

**CAUTION:**

Do not bundle any lines from this unit with transmitter coax feed lines. Do not bundle any logic, audio, or DC power lines from this unit with 400 Hz synchro wiring or AC power lines. Do not position this unit next to any device with a strong alternating magnetic field such as an inverter, motor or blower, or significant audio interference will result.

In all installations, use shielded cable exactly as shown, and ground only as indicated. Significant problems may result from not following these guidelines.

Failure to follow the installation and wiring instructions provided in this manual for power and ground connections, including the rating of the circuit breaker, may lead to damage in the power input circuitry of the unit.

### 2.4.3 Cabling and Wiring

---

All wire shall be selected in accordance with the original aircraft manufacturer's Maintenance Instructions or AC43.13-1B Change 1, Paragraphs 11-76 through 11-78. Unshielded wire types shall qualify to MIL-W-22759 as specified in AC43.13-1B Change 1, Paragraphs 11-85, 11-86, and listed in Table 11-11. For shielded wire applications, use Tefzel MIL-C-27500 shielded wire with solder sleeves (for shield terminations) to make the most compact and easily terminated interconnect. Follow the connector map in Section 2.7 as required.

Allow 3" from the end of the shielded wiring to the shield termination to allow the connector hood to be easily installed. Reference the interconnect drawing in Section 2.7 for shield termination details. Note that the hood is a "clamshell" hood, and is installed after the wiring is complete. Aircraft harnessing shall permit the unit to be removed from the panel for easy access to all side adjustments. Do NOT mount the unit until all adjustments have been performed.

Maintain wire segregation and route wiring in accordance with the original aircraft manufacturers Maintenance Instructions.

Unless otherwise noted, all wiring shall be a minimum of 22 AWG, except power and ground lines, which shall be a minimum of 20 AWG. Reference the Interconnect drawing for additional specifications. Check that the ground connection is clean and well secured, and that it shares no path with any electrically noisy aircraft accessories such as blowers, turn and bank instruments or similar loads. Power to this unit must be supplied from a separate circuit breaker or fuse (fast blow), and not attached to any other circuit breaker without additional protection. Verify that the selected circuit breaker size and wire gauge are adequate for the installation using the techniques specified in AC43.13-1B Change 1, Paragraphs 11-47 through 11-51 and 11-66 through 11-69.

### 2.4.4 Post Installation Checks

---

Perform any required adjustments of preset levels, and ensure that the audio controller is properly mounted and secured prior to flight.



## AMS43 Single Channel Audio Controller SM59 Installation and Operation Manual

---

### 2.4.4.1 Voltage/Resistance Checks

**Do not attach the AMS43 until the following conditions are met.**

Check the following:

- a) P101 pins <16> and <17> for +28 Vdc relative to ground.
- b) P101 pin <34> for continuity to ground (below 0.5  $\Omega$ ).
- c) P102 pin <19> for +28 Vdc lights bus voltage.
- d) Check all Mic, phone, music and key lines for shorts to ground or adjacent pins.

### 2.4.4.2 Power On Checks

Power up the aircraft's systems and confirm normal operation of all functions of the AMS43. Refer to Section 3 (Operation) for specific operational details.

Start with only the pilot's headset installed. Check for correct Intercom (ICS), radio, and transmit (TX) operation. Do not proceed until the radios are functioning correctly. The S/T trimpot accessible through the left side of the controller and the transceiver internal trimpot may have to be adjusted for correct balance for the pilot. Adjustment of the individual radio receive (RX) levels should be set first with the AMS43 in **PILOT ISO/EMR** (Pilot isolate/emergency) mode, then adjust the AMS43 front panel RX master volume control level in **NORMAL** mode.

Unusual buzzes, hums or other background audio are symptomatic of multiple grounds or noisy external systems sharing the same wire bundle. Incorrect jack wiring is a common fault, especially for passenger stations, and may cause loss of audio, a tone on the headset lines, or other problems. Failure to key or correctly modulate a transceiver may be caused by missing grounds on the radio or audio controller.

Plug in the hand mic and test for correct operation. Wiring faults for this accessory may cause peculiar loss of ICS or TX functions because it has over-riding priority in the system.

Plug in the remaining headsets and check for proper operation. An incorrect drop cord or improper jack wiring may cause a wide range of problems from loss of audio to a tone heard in the headset. For further information, see section 2.5.3 below.

Check levels and operation of all functions in flight to ensure proper adjustments and settings have been made.

Upon satisfactory completion of all performance checks, make all required log book entries, electrical load, weight and balance amendments and other documentation as required by your local regulatory agency before releasing the aircraft for service.

## 2.5 Adjustments and Connections

---

The unit ships from the factory with all internal adjustments set to the normal test levels. Once installed in the aircraft, it may be desirable to change some of these settings to best suit the local operating environment.

The internal adjustments are located on the sides of the unit and are as follows:



## AMS43 Single Channel Audio Controller SM59 Installation and Operation Manual

### 2.5.1 Left Side panel adjustments

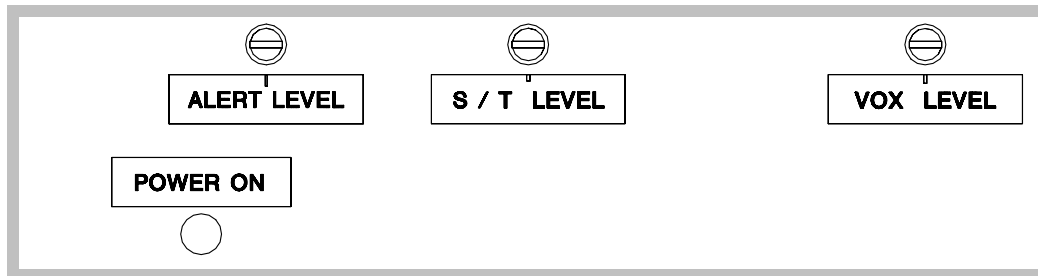

The trimpots on the left side panel are used to adjust the levels of audio in the user's headphones. Rotating the trimpots clockwise (cw) increases the level, and counterclockwise (ccw) reduces it.

The **ALERT LEVEL** trimpot is used to adjust the levels for the three internally generated Alert signals. Other parameters relating to these signals are adjusted from the right side panel (see section 2.3.4.2.) The **S/T LEVEL** trimpot adjusts the internal gain of the sidetone (S/T) of the selected transceiver (from the front panel) in the user's headphones.

The **VOX LEVEL** trimpot sets the sensitivity level for the front panel **VOX** control (the level of audio required to activate microphones).

The **POWER ON** LED will illuminate to indicate that the unit is connected to the power supply.

### 2.5.2 Right Side Panel Adjustments



A variety of different signals can be selected to trigger the internal Alert signals. The trimpots on the right side panel are used to adjust the characteristics of the audible signals that the user will hear.

Audio Alert 1 is a single tone signal and Audio Alerts 2 and 3 are two-tone signals. The pitch of the signals can be adjusted using the relevant **TONE** trimpot, and the cycling rate of the two-tone signals can be adjusted using the **RATE** trimpots. The duration of Audio Alert 3 can be adjusted from one to three seconds using the **TIME** trimpot.

The **DIR AUD LEVEL** trimpot is used to adjust the audio level of the devices connected to the DIR AUD 1 input.

### 2.5.3 In-line PTT Drop Cords

#### 2.5.3.1 General

In-line, push-to-talk (PTT) drop cords (also known as cordsets) can be used to create/provide PTT capability for the user headsets that do not have yoke or cyclic mounted PTT switches. For headsets connected to the PILOT or COPILOT inputs/outputs of the AMS43, ICS and TX keylines are needed to properly activate the associated PTT circuitry inside the AMS43. For headsets connected to the PASSENGER inputs/outputs of the AMS43, a method of controlling the microphone on the headset is needed because of the 'hot mic' circuitry. This is best accomplished with a 'mic interrupt' switch in the PTT drop cord.



## AMS43 Single Channel Audio Controller SM59 Installation and Operation Manual

There are numerous manufacturers of in-line PTT drop cords, offering many 'electrical' variations to accomplish different functions. To meet the operational requirements for headset stations supported by the AMS43, NAT recommend the dual switch type: a 3-position (momentary/center-off/locking) slider switch for the ICS functions, and a momentary, push-button switch for the TX functions. Both switches provide a 'mic interrupt' function. The 3-position ICS switch will allow the user to change the switch settings to match the operational intercom mode that has been selected at the AMS43 (e.g., LIVE, KEYED or VOX). The cable should have 6 conductors, with the MIC and PHONE pairs shielded (MIC wires must be shielded as a minimum). To ensure proper shielding, the shield(s) should be terminated to the MIC LO connection at the airframe connector of the PTT drop cord. See the drawing below for details.

### PTT Cord for Use with NAT Audio Controllers (XMIT and ICS)

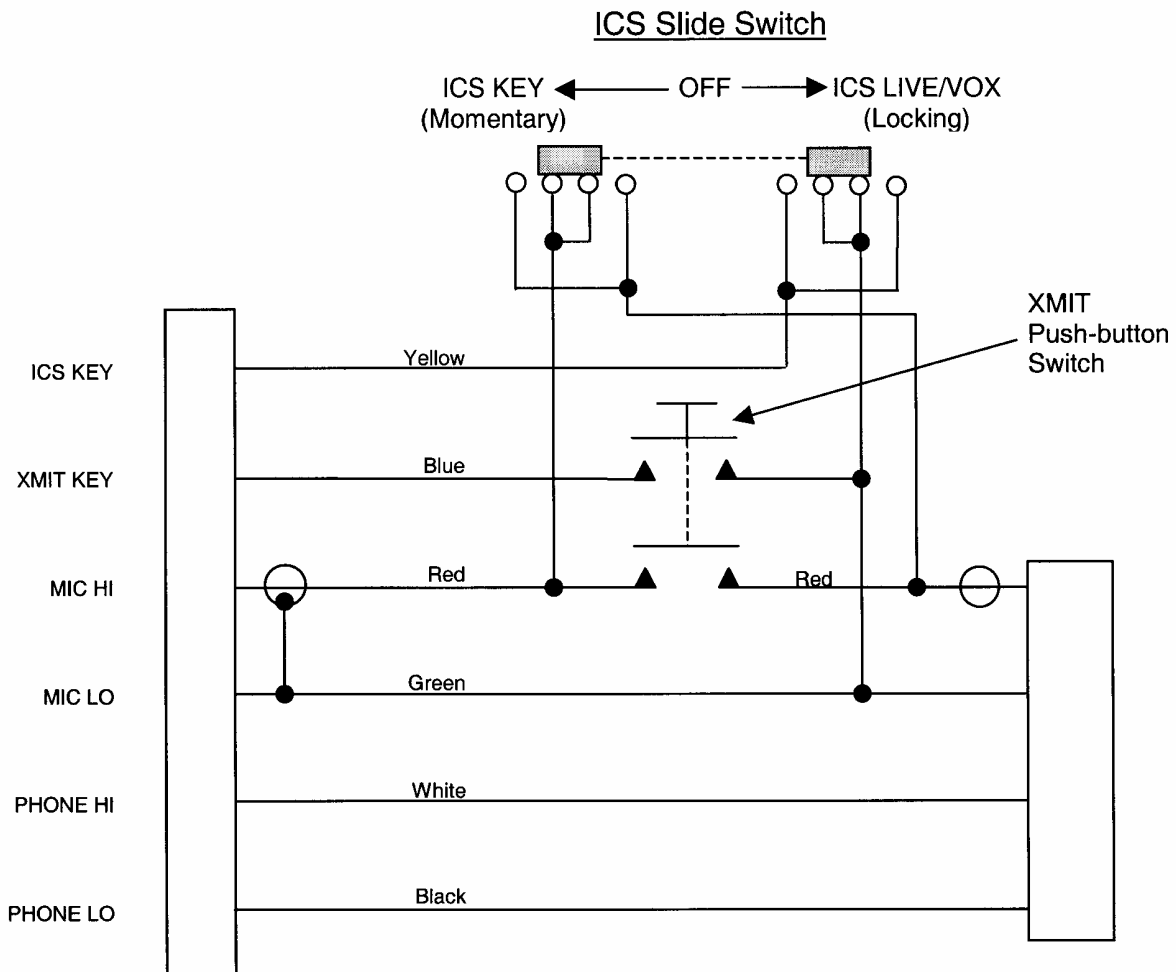

To avoid complications in the aircraft, it is recommended that the same type of PTT drop cord is used for all headset locations in the aircraft. It is not good practice to create a situation where a specific drop cord is needed for the copilot, which might cause operational errors if moved to a passenger location.



# AMS43 Single Channel Audio Controller SM59 Installation and Operation Manual

## 2.5.3.2 Cautions

**CAUTION:**

Although in-line PTT drop cords can be used to conveniently address a number of requirements for microphone and PTT control, they can also be a source of trouble if incorrectly configured, or improperly shielded.

Many in-line PTT drop cords use the PHONE LO connection as the ground reference for the ICS and TX PTT keylines. The PHONE LO connection in the AMS43 is floating, which will lead to incorrect keying of the intercom and radio systems if this type of drop cord is used.

In-line PTT drop cords can be a very real source for crosstalk if the MIC wire pair in the drop cord is not shielded. The source of the crosstalk is the high level Phones audio being coupled on to the MIC HI/LO pair in the in-line PTT drop cord, because of the lack of shielding for this wire pair. Once the mic line is contaminated, the undesired audio can be sent into the audio system as 'mic audio', then processed and distributed to all other audio controllers via the ICS Tie Line.

## 2.6 Accessories Required But Not Supplied

Installation kit AA90-IKC (Alt. part No. D50S37SL-IKC) is required to complete the installation. The kit consists of one 50-Pin D-min Female Crimp Kit (D50SL-IKC) and one 37-Pin D-min Female Crimp Kit (D37SL-IKC).

**D50SL-IKC** consists of

Quantity	Description	NAT Part #
1	D-min 50 Socket Housing	20-21-050
50	MS Crimp Socket	20-26-901
1*	Jack Screw Set	20-27-002
1*	Lock Clip Set	20-27-004
1	50 Pin Connector Hood	20-29-051

**D37SL-IKC** consists of

Quantity	Description	NAT Part #
1	D-min 37 Socket Housing	20-21-037
37	MS Crimp Socket	20-26-901
1*	Jack Screw Set	20-27-002
1*	Lock Clip Set	20-27-004
1	37 Pin Connector Hood	20-29-038

\* Use as required.



**AMS43 Single Channel Audio Controller  
SM59 Installation and Operation Manual**

---

**2.7 Installation Drawings**

---

<b>DRAWING</b>	<b>REV.</b>	<b>DESCRIPTION</b>	<b>TYPE</b>	<b>SERIAL No.</b>
AMS43\403-0	1.12	Audio Controller	Interconnect	2580 and up
AMS43\403-1	1.12	Audio Controller	Interconnect	2580 and up
AMS43\403-2	1.12	Audio Controller	Interconnect	2580 and up
AMS43\405-0	1.00	Audio Controller	Connector Map	2580 and up
AMS43\905-0	1.12	Single Channel Audio Controller	Faceplate sht 1 of 3	2580 and up
AMS43\922-0	1.01	Audio Controller	Mech. Installation	2580 and up

**Section 2 ends following the above documents**

---

REVISIONS			
REV	DESCRIPTION	DATE	BY
1.10	FORMAT CHANGES.	SEP 30/94	TM
1.11	ECR #787 - FORMAT CHANGES.	JUL 27/98	TAT
1.12	DOCCRO1361 - FORMAT CHANGES	SEP 30/05	TAT

AMS43 INSTALLATION NOTES

NOTES:

1. ALL WIRES SHOULD BE 22 AWG UNLESS OTHERWISE SPECIFIED. ALL UNSHIELDED WIRE SHALL BE SELECTED IN ACCORDANCE WITH AC43.13-1B CHANGE 1, PARAGRAPHS 11-76 THROUGH 11-78. WIRE TYPES SHOULD BE TO MIL-W-22759 AS SPECIFIED IN AC43.13-1B CHANGE 1, PARAGRAPHS 11-85, 11-86 AND LISTED IN TABLE 11-11. ALL SHIELDED WIRE/CABLE SHOULD BE IN ACCORDANCE WITH MIL-C-27500.

△ HEADPHONE, MICROPHONE AND ICS TIE LINES USE TWISTED SHIELDED PAIR. CONNECT SHIELDS TOGETHER AND GROUND TO CLEAN AIRCRAFT GROUND. GROUND POINT SHOULD BE THE SAME AS AIRCRAFT AUDIO SYSTEM POWER GROUND.

△ DO NOT GROUND MICROPHONE OR HEADPHONE LO CONNECTIONS TO AIRFRAME.

△ ADJUSTABLE LEVEL DIRECT AUDIO INPUT, AMPLIFIED.

△ FIXED LEVEL DIRECT AUDIO INPUT. NO ADJUSTMENT. DO NOT PARALLEL FROM SINGLE SOURCE AUDIO TO OTHER AUDIO CONTROL PANELS.

△ AIRCRAFT ENTERTAINMENT SYSTEM (TAPE) MUST BE GROUND REFERENCED. IF NOT, A FLOATING GROUND ADAPTER BETWEEN THE AUDIO CONTROLLER AND ENTERTAINMENT SYSTEM WILL BE REQUIRED.

△ TO BE USED FOR EXPANSION OF INTERCOM SYSTEM ONLY. REFER TO INSTALLATION MANUAL FOR DETAILS.

DEFINITIONS:

N/C: NO CONNECTION. THE PIN IS NOT CONNECTED TO ANYTHING INTERNALLY, AND THEREFORE SHALL HAVE NO CONNECTION EXTERNALLY.

N/C SPARE: NO CONNECTION INTERNALLY, BUT A SPARE WIRE SHALL BE INSTALLED IN THE WIRE HARNESS.

RESERVED: MAY BE CONNECTED AND USED IN THE FUTURE. THE CIRCUITRY MAY BE PRESENT OR ADDED TO ACTIVATE THE FUNCTION. THE PIN MAY BE USED FOR TEST PURPOSES. THERE IS NO EXTERNAL CONNECTION.

RESERVED SPARE: RESERVED, BUT INSTRUCTIONS SHALL BE FOLLOWED TO ACTIVATE THE CIRCUITRY. A SPARE WIRE SHALL BE INSTALLED IN THE WIRE HARNESS.

CONFIDENTIAL AND PROPRIETARY TO NAT LTD.

DESIGNED	KV	 <b>nat</b> NORTHERN AIRBORNE TECHNOLOGY LTD.				
DRAWN	KV/TM					
DATE	JUL 27/90	TITLE AUDIO CONTROLLER				
CHECKED	<b>NAT 249</b>					
APPROVED	<b>NAT 131</b>	SIZE A	CAGE CODE 3AB01	PART NO. AMS43	REV. 1.12	SHEET 1/3
FILE	403-0.DWG	DWG. TYPE	INTERCONNECT	DWG. NO.	AMS43\403-0	

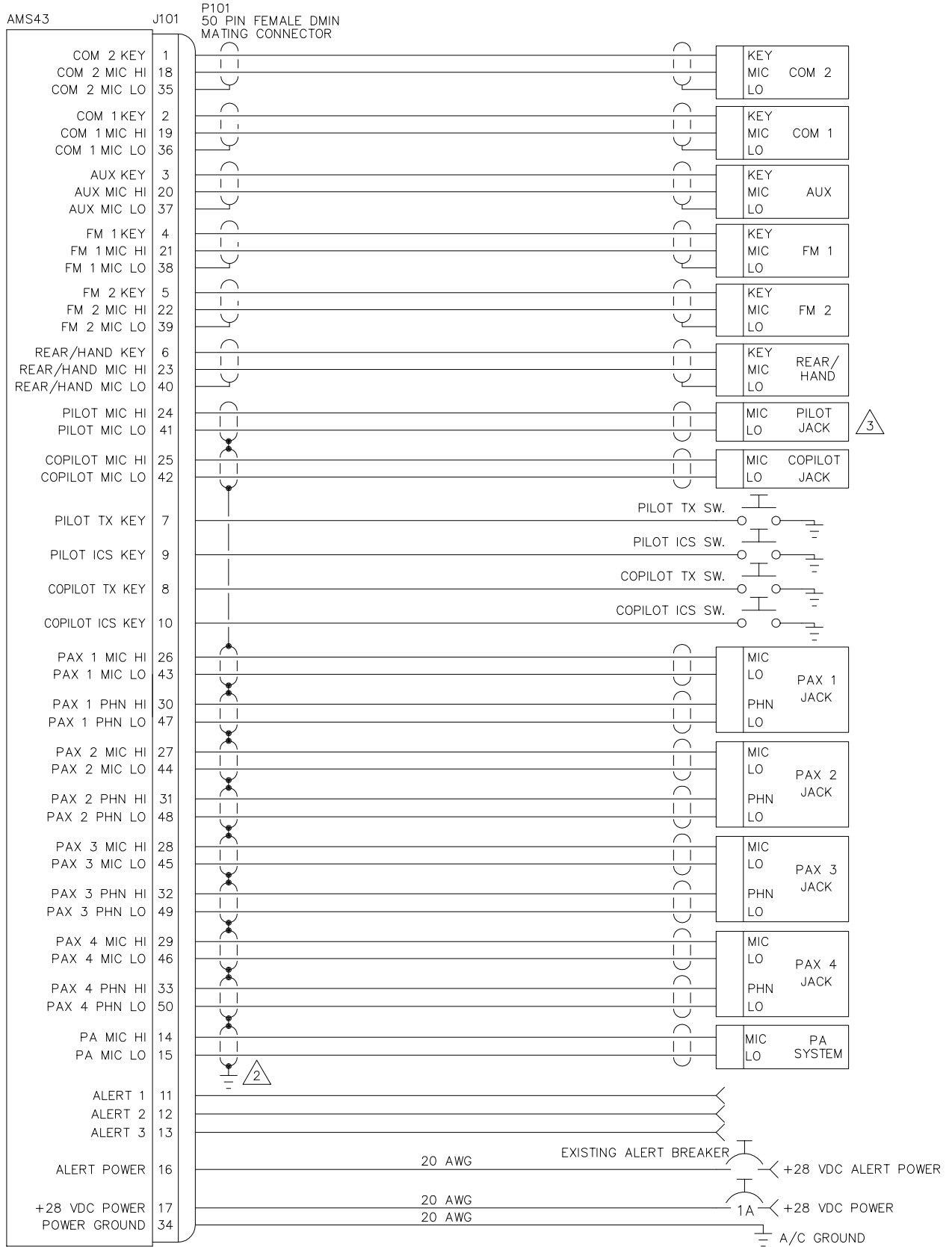

CONFIDENTIAL AND PROPRIETARY TO NAT LTD.

DESIGNED	KV	 <b>NAT</b> NORTHERN AIRBORNE TECHNOLOGY LTD.				
DRAWN	KV					
DATE	JUL 27/90	TITLE <b>AUDIO CONTROLLER</b>				
CHECKED	<b>NAT 249</b>					
APPROVED	<b>NAT 131</b>	SIZE	CAGE CODE	PART NO.	REV.	SHEET
		A	3AB01	AMS43	1.12	2/3
FILE	403-0.DWG	DWG. TYPE	INTERCONNECT	DWG. NO.	AMS43\403-1	

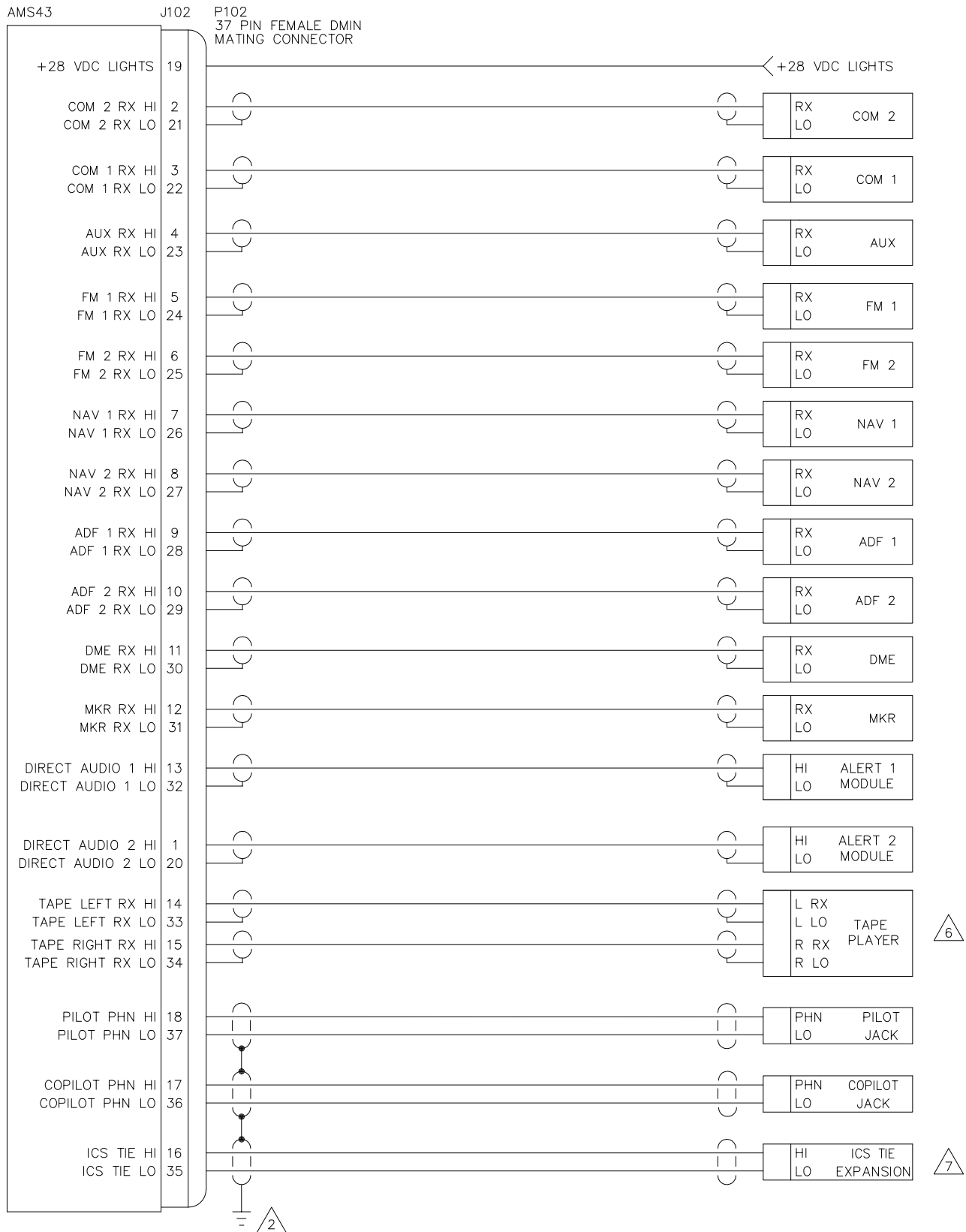

CONFIDENTIAL AND PROPRIETARY TO NAT LTD.

DESIGNED	KV	<b>NAT</b> NORTHERN AIRBORNE TECHNOLOGY LTD.			
DRAWN	KV				
DATE	JUL 27/90	TITLE			
CHECKED	NAT 249	AUDIO CONTROLLER			
APPROVED	NAT 131	SIZE	CAGE CODE	PART NO.	REV.
		A	3AB01	AMS43	1.12
FILE	403-0.DWG	DWG. TYPE	INTERCONNECT	DWG. NO.	AMS43\403-2
					SHEET 3/3

P102

37 PIN FEMALE DMIN MATING CONNECTOR

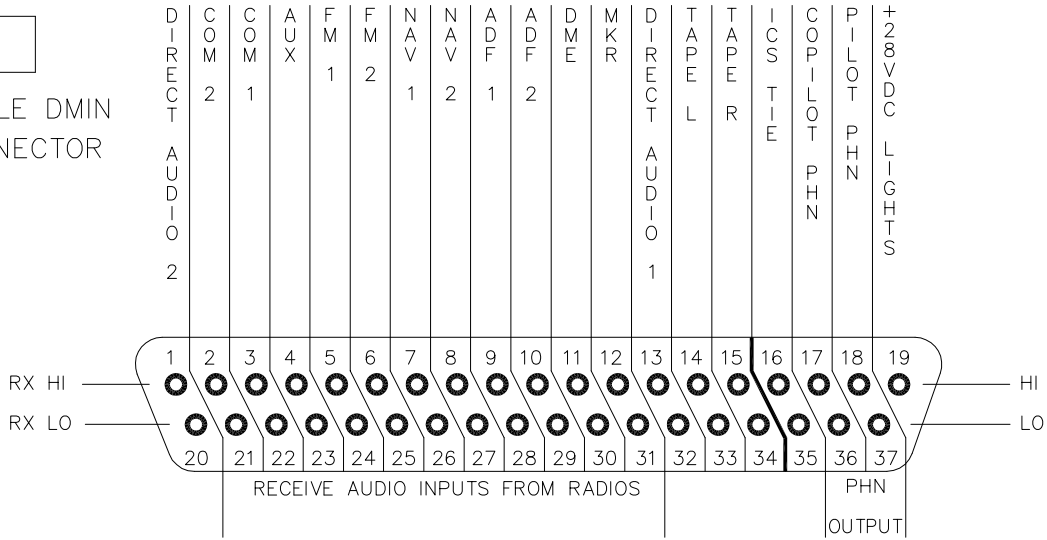

P101

50 PIN FEMALE DMIN MATING CONNECTOR

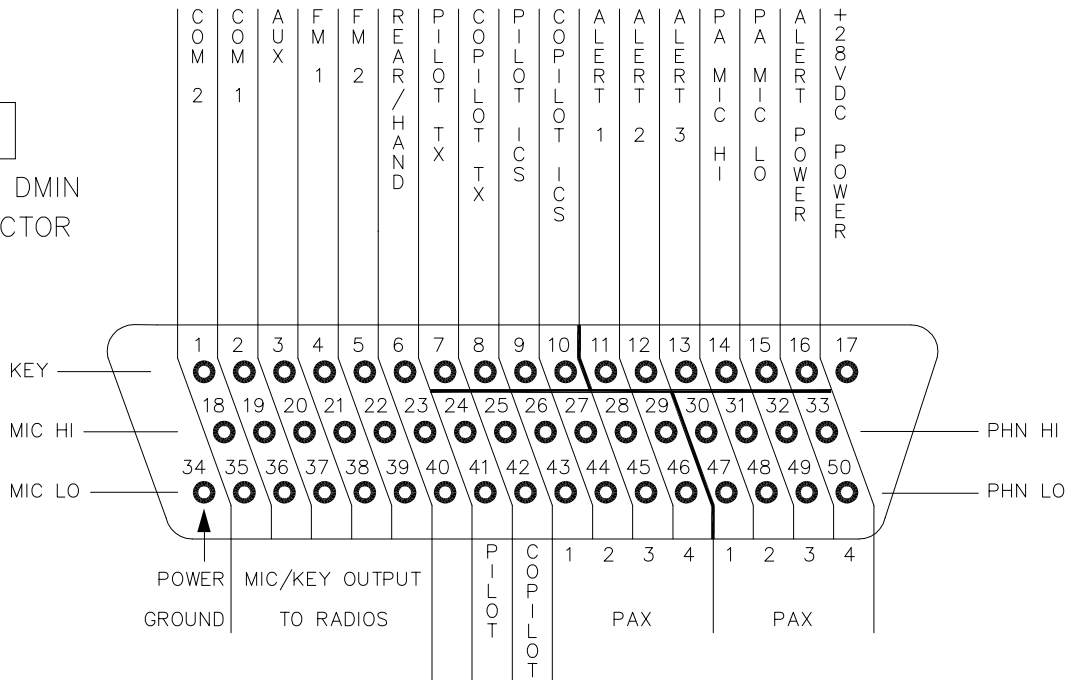

NOTE: DO NOT GROUND HEADSET COMMONS  
VIEW IS FROM REAR OF AIRFRAME CONNECTOR

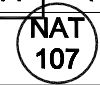

PROPRIETARY AND CONFIDENTIAL TO NAT LTD.

DESIGNED	RV	 <b>NAT</b> NORTHERN AIRBORNE TECHNOLOGY LTD.				
DRAWN	TAT					
DATE	JUL 27/98	TITLE				AUDIO
CHECKED	<b>NAT</b> PROD.	214 105				CONTROLLER
APPROVED		SIZE	CAGE CODE	PART NO.	REV.	SHEET
FILE	405-0100.DWG	A	3AB01	AMS43	1.00	1/1
DWG. TYPE		CONNECTOR MAP		DWG. NO.		AMS43\405-0

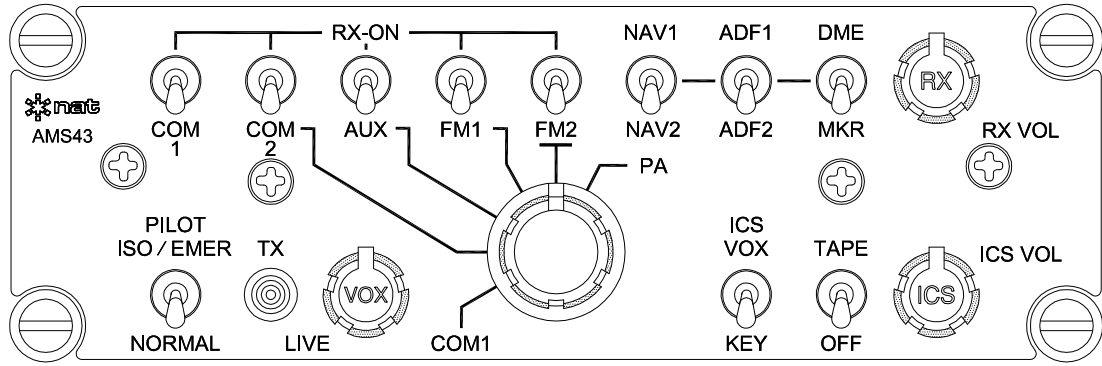
REVISIONS			
REV	DESCRIPTION	DATE	BY
1.10	CHANGED KNOBS, DWG CORRECTIONS.	APR 26/96	MWS
1.11	ECR #787 - FORMAT CHANGES.	JUL 27/98	TAT
1.12	DOCCRO2415 - UPDATED TO CURRENT STANDARDS.	MAY 14/08	MWS



CONFIDENTIAL AND PROPRIETARY TO NAT LTD.

DESIGNED	KV		NORTHERN AIRBORNE TECHNOLOGY LTD.					
DRAWN	KV							
DATE	AUG 14/87	TITLE	AUDIO CONTROLLER FRONT VIEW					
CHECKED	NAT 105	NAT 255						
APPROVED		SIZE	CAGE CODE	PART NO.	REV.	SHEET		
FILE	905-0.DWG	A	3AB01	AMS43	1.12	1/3		
		DWG. TYPE	FACEPLATE	DWG. NO.	AMS43\905-0			

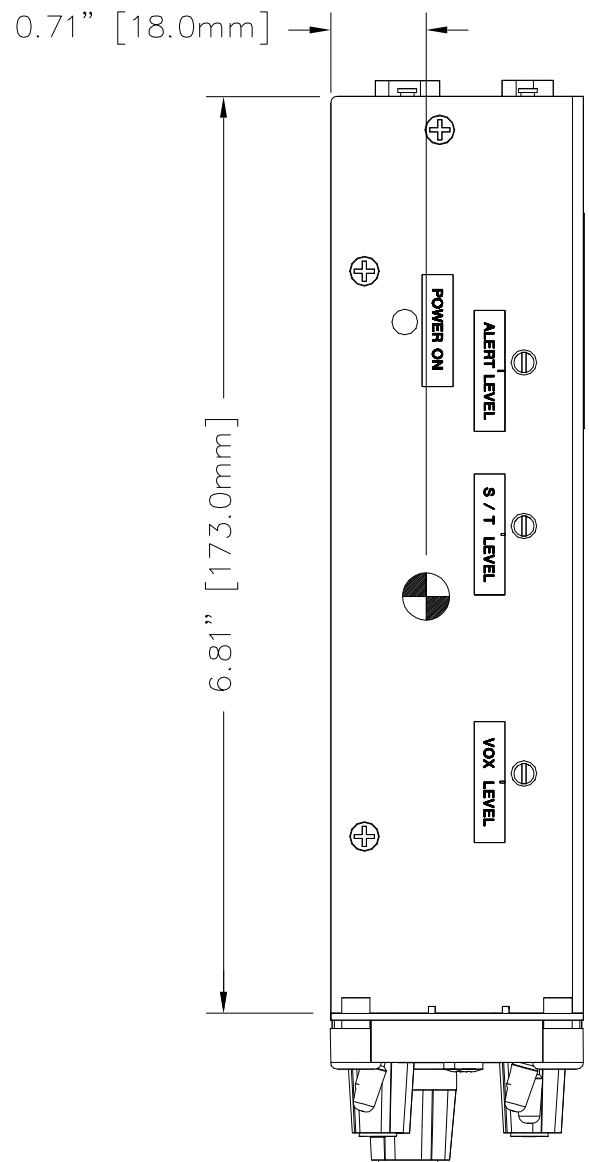

1.12" ± 0.03" [28.5mm ± 0.8mm]

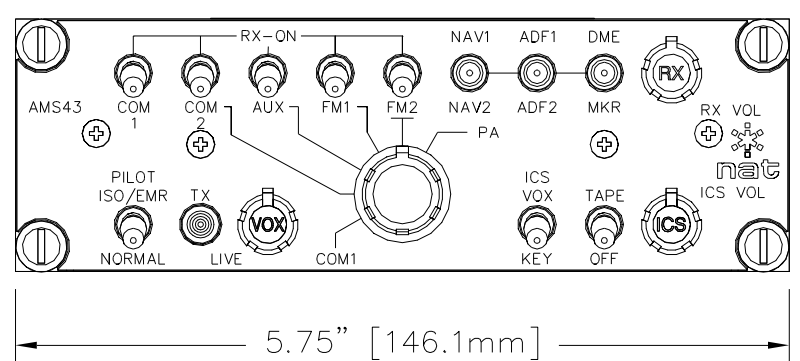
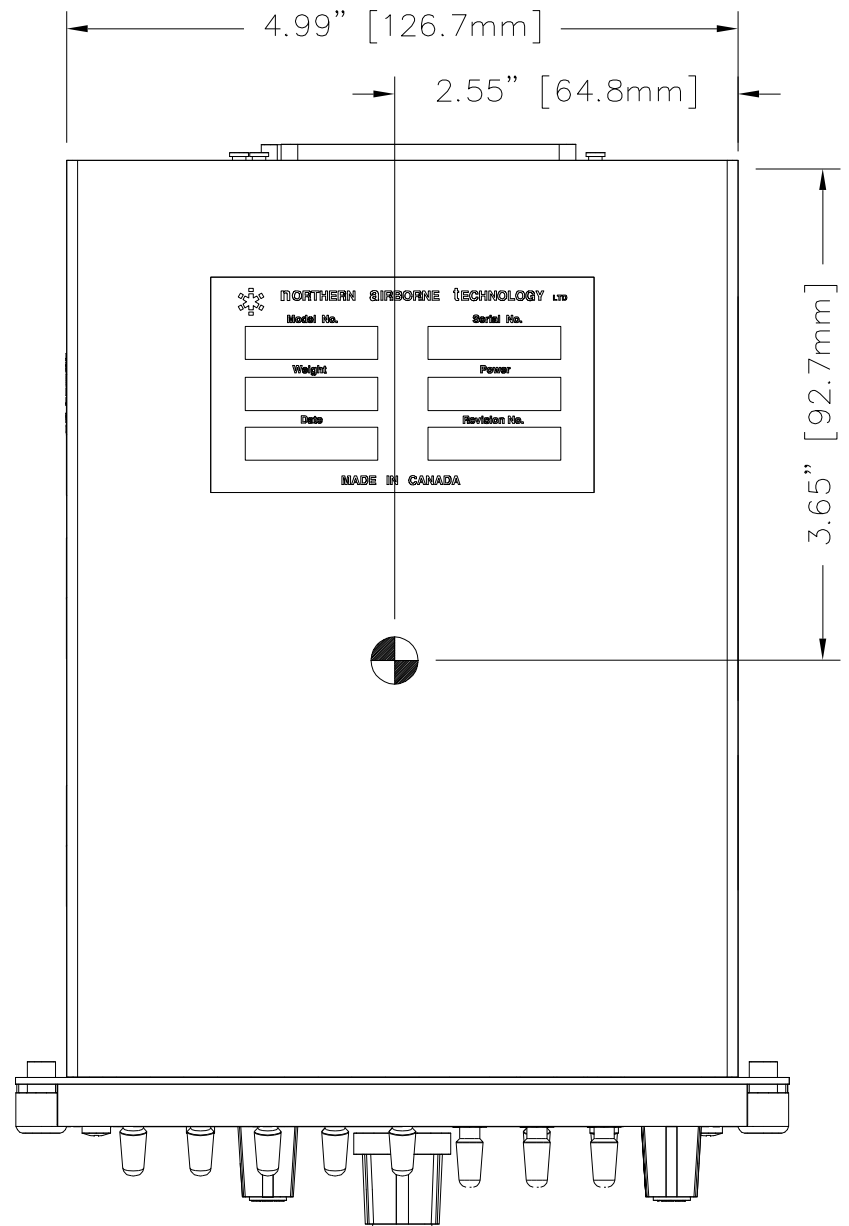

1.88" [47.7mm]

CENTER OF GRAVITY  
WEIGHT: 2.1 lbs. (1.0 kg)

REVISIONS			
REV	DESCRIPTION	DATE	BY
1.01	ECR #787 - DRAWING WAS 910-0100.DWG, FORMAT CHANGES.	MAR 9/99	TAT

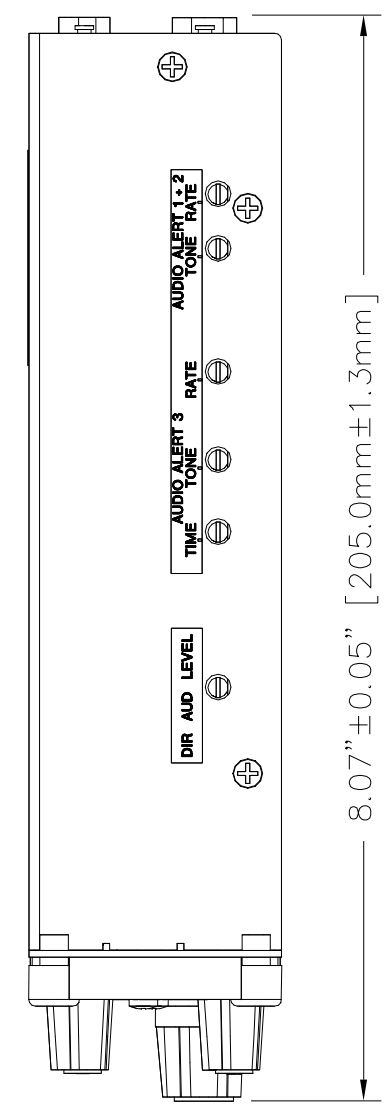

PROPRIETARY AND CONFIDENTIAL TO NAT LTD.

TOLERANCES UNLESS STATED OTHERWISE 0.X=+/-0.030 0.XX=+/-0.010 0.XXX=+/-0.005 0.XXXX=+/-0.002 ANGLE=+/- 0.5 DEG.	DIMENSIONS IN INCHES THIRD ANGLE PROJECTION	DESIGNED	KV		<b>NAT</b> NORTHERN AIRBORNE TECHNOLOGY LTD.
		DRAWN	TB		
		DATE	JAN 27/94		TITLE
		CHECKED	NAT 200	NAT 214	AUDIO CONTROLLER
MATERIAL		APPROVED	NAT 107	SIZE B	CAGE CODE 3AB01
FINISH		FILE	922-0101.DWG		DWG. TYPE MECH. INSTALLATION
			PART NO.	AMS43	REV. 1.01
			DWG. NO.	AMS43\922-0	
			SHEET	1/1	



# AMS43 Single Channel Audio Controller SM59 Installation and Operation Manual

## Section 3 Operation

### 3.1 Introduction

Information in this section consists of functional and operational procedures for the AMS43 Single Channel Audio Controller.

### 3.2 General Information

The AMS43 provides control for all aircraft audio, allowing selection of transmit (TX) and receive (RX) audio, LIVE, KEYED, or voice activated (VOX) intercom, interface for an additional hand held transmit microphone (hand mic), and pilot isolation/emergency (PILOT ISO/EMR) operation.

Sidetone (S/T) level is adjustable internally, and RX and intercom (ICS) levels are adjustable on the front panel. All audio, except the S/T of the radio in use and the directly connected DIRECT AUDIO 2 input signal (see Section 3.5.1), is muted during TX for clarity. ICS operation allows TX during any ICS mode by using the push-to-talk (PTT) switch.

### 3.3 Controls and Indicators

All TX and public address (PA) functions are controlled with a single rotary selector switch. RX audio, ICS operations and tape audio are controlled with colour-coded toggle switches. RX volume, ICS volume and ICS VOX squelch are individually adjusted with rotary controls.

#### 3.3.1 Receive Audio Select Switches

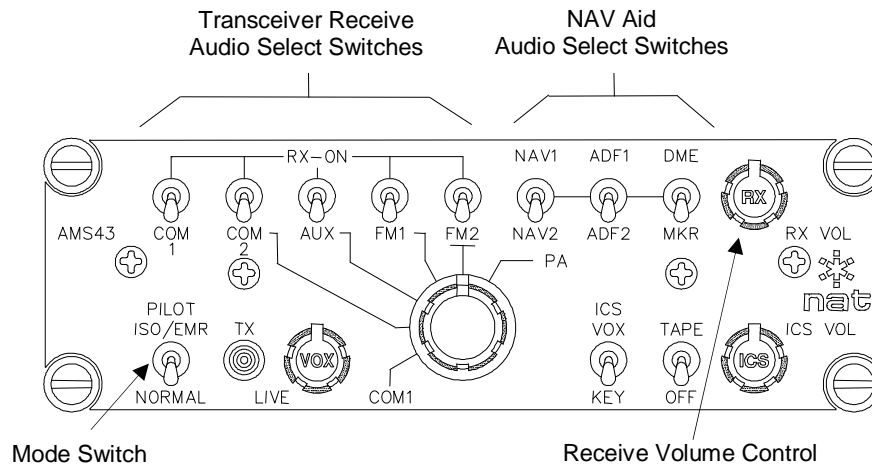

The transceiver RX audio select switches (white switch bats) are two-position switches. When set to the up position, the respective transceiver RX audio is selected on. When set to the down position, the respective transceiver RX audio is selected off.

The NAV RX audio select switches (blue switch bats) are three-position switches. When set to the up or down position, the respective NAV RX audio is selected on. When set to the center off position, the respective NAV RX audio is selected off.



## AMS43 Single Channel Audio Controller SM59 Installation and Operation Manual

The master RX volume control (**RX VOL**) adjusts all RX audio concurrently from 1% to full. It is important to set the individual radio volume controls to a nominal level, and then use the master **RX VOL** control on the audio controller to adjust for changing flight conditions.

When the red mode switch is set to **NORMAL**, the passengers will hear the radio audio as selected on the controller. The passengers will not hear any radio audio when the red mode switch is in the **ISO/EMR** position.

### 3.3.2 Transmit Selector Switch

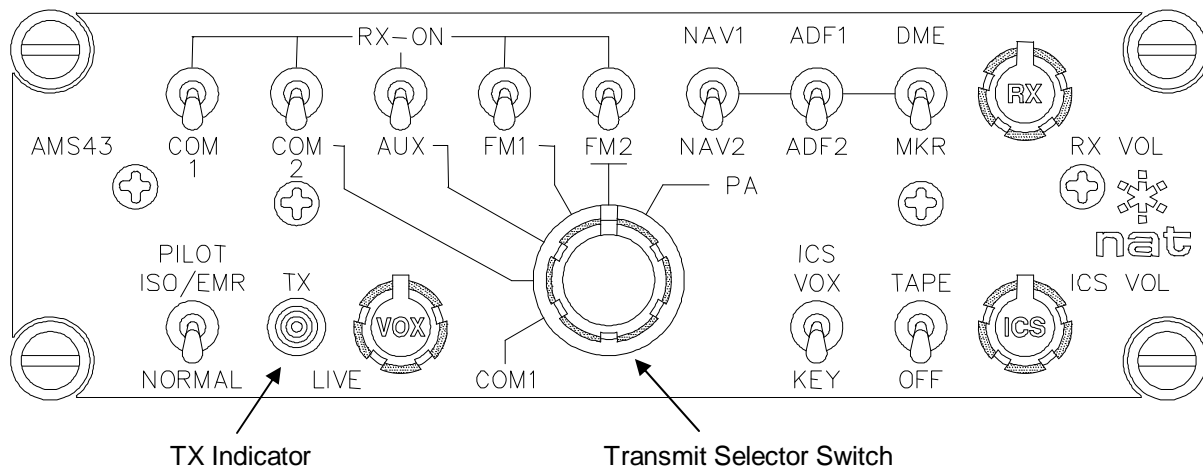

The TX selector switch is a six-position switch used to select the desired transceiver. When rotated fully clockwise, this switch selects the PA function. When the hand mic or TX PTT switch is activated, the mic will be coupled to the radio (or PA) selected. The pilot has priority over the copilot during TX operations.

RX audio for the transceiver selected is automatically activated as a function of the rotary selector switch, and no additional switching is needed to establish outside communication. During TX, all audio selected is muted except the sidetone of the transceiver in use.

The front panel TX indicator will illuminate green when either the pilot or co-pilot transmits. It will not light when the hand mic is used.



## AMS43 Single Channel Audio Controller SM59 Installation and Operation Manual

### 3.3.3 ICS Functions

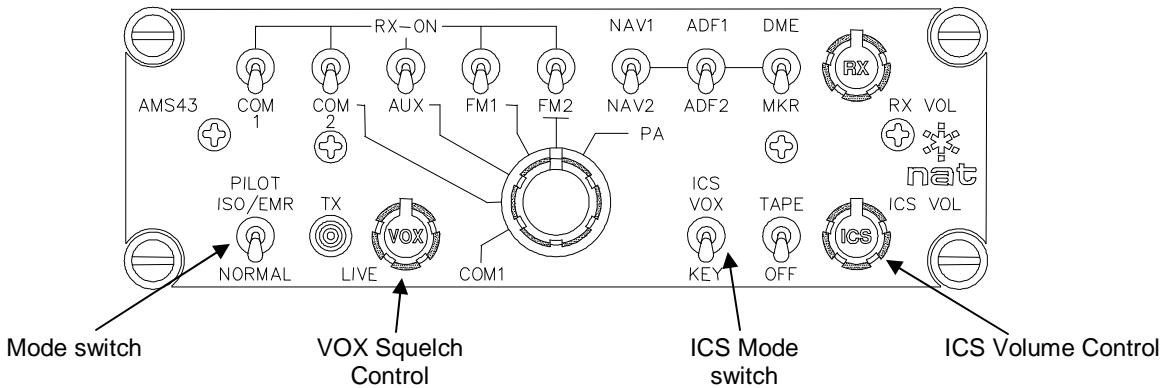

#### 3.3.3.1 ICS Modes

ICS audio may be implemented in three modes: LIVE (on constantly), VOX (voice activated), or KEYED (active only when switched by ICS PTT switch). It is common to use the LIVE mode during ground operations, start-up, etc. and to use VOX or KEYED operation if conditions are so noisy that 'pilot fatigue' will result.

##### LIVE (Hot Mic Operation)

ICS mode switch (orange switch bat) set to the **VOX** (up) position and the VOX squelch control set to the full counter-clockwise position.

##### KEYED ICS (PTT Operation)

ICS mode switch (orange switch bat) set to the **KEY** (down) position. Keyed ICS is inherent to the pilot and copilot microphone circuits only. Passenger microphone circuits will be LIVE with this mode selected.

##### VOX (Voice Activated)

ICS mode switch (orange switch bat) set to the **VOX** (up) position. Set the ICS VOX Squelch control fully counter-clockwise and then slowly rotate clockwise until the ICS just becomes quiet. This setting will vary with ambient noise conditions, and the quality and number of microphones connected in the system.

#### 3.3.3.2 General ICS Functions

Passenger ICS audio is LIVE when the controller is in the LIVE or KEYED mode of ICS operation. In the KEYED mode of operation the passenger microphones are LIVE. Utilize drop cord assemblies incorporating microphone circuit interrupt switches for keyed ICS operation. Passenger ICS is VOX triggered when VOX mode is selected.

All ICS audio is controlled by the front panel ICS volume control and may be varied to suit conditions. The ICS VOL control provides adjustment from approximately 1% to full output.

The mode switch (red switch bat) is used to select between **NORMAL** and **PILOT ISO/EMR** modes. In the **NORMAL** position (down), all operations of the ICS are functional as described above. When the switch is in the **PILOT ISO/EMR** position, the pilot is isolated from the rest of the passengers. If the controller is operated in the **ISO/EMR** mode, ICS operation will continue (if there is no fault condition) between the passengers and copilot, but will exclude the pilot. See section 3.4 for further details.



## AMS43 Single Channel Audio Controller SM59 Installation and Operation Manual

---

### 3.4 Emergency Operation

---

When the red **PILOT ISO/EMR - NORMAL** mode switch is set to the **ISO/EMR** position, the pilot is removed from the ICS bus and connected directly to the selected radios. This mode should be selected in the event of a box fault or power failure.

In the **ISO/EMR** mode, all functions are retained by the pilot, except ICS and possibly boom mic operation. If the box or airframe fault prevents the TX annunciator from lighting during transmit (indicating a failure in the mic keying circuit), then the hand mic should be used. A power fault of any kind will prevent the TX annunciator from lighting, giving an immediate indication of failure. If ICS audio is still available, then the power to the controller has not failed, and loss of the TX light indicates TX switch failure.

In the **ISO/EMR** mode, all switches work exactly as they do during **NORMAL** operation, except for the RX and ICS volume controls, which have no effect.

The **ISO/EMR** function should be tested prior to flight to ensure proper operation, and allow the radio levels to be set adequately for emergency operation.

Any selected RX audio is switched to the primary user (pilot) in the **ISO/EMR** mode, but not to any passengers in the system. Audio level will be lower than in **NORMAL** operation because the signals are obtained directly from the radios, bypassing the electronics in the controller. This is provided for failure situations that make operation impossible in the **NORMAL** mode (i.e., loss of power or amplifier failure, etc.)

### 3.5 Audio Alerting Functions

---

Two types of audio alerting are supported in the AMS43: Direct Audio and Internal Alerting. The use of these alerting features should be determined, defined and recorded so that the operator has an opportunity to use these features as they were intended for their specific installation.

#### 3.5.1 Direct Audio

---

Direct Audio is when an audio signal from an existing warning system is connected 'directly' into the audio system, and is not front panel selectable. There are two Direct Audio inputs on the AMS43. Direct Audio 1 is amplified/adjustable and Direct Audio 2 is connected directly to the pilot's headset output.

#### 3.5.2 Internal Alerting

---

Internal Alerting is provided by three separate, internal tone generators that are coupled to the headset output. These tones are a function of the AMS43 itself, and can be used to supplement existing warning tones (Low Rotor, Engine Out warnings in a Bell 206) or provide unique alerting capability for functions such as ICS Call, Rad Alt DH warning, etc. The internal alerts, and how they will be used, are determined at the time of installation and are not front panel selectable.

**Section 3 ends**

---