

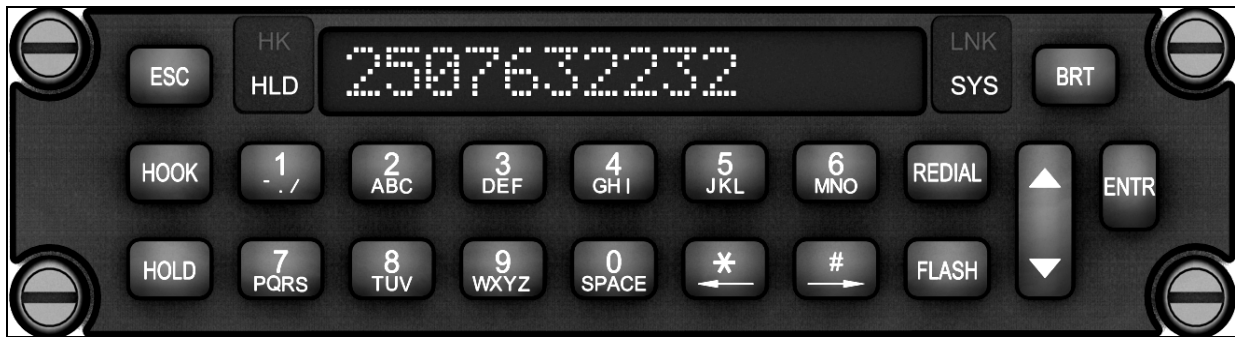

Installation and Operation Manual

PTA12-300 POTS Telephone Adapter with NVIS Display



SM55-3

ISSUE 4.02

Northern Airborne Technology Ltd.
1925 Kirschner Road
Kelowna, BC, Canada.
V1Y 4N7
Telephone (250) 763-2232
Facsimile (250) 762-3374

Issued on the authority of Northern Airborne Technology Ltd.

Copyright 2005



PTA12-300 POTS Telephone Adapter with Display
SM55-3 Installation and Operation Manual

Table of Contents

| Section | Title | Page |
|-----------|---------------------------------------|------|
| 1. | Description | |
| 1.1 | Introduction | 1-1 |
| 1.2 | Product Description | 1-1 |
| 1.3 | Design Features | 1-1 |
| 1.4 | Specifications | 1-2 |
| 1.4.1 | Electrical Specifications | 1-2 |
| 1.4.2 | Physical Specifications | 1-5 |
| 1.4.3 | Environmental Specifications | 1-6 |
| 2. | Installation | |
| 2.1 | Introduction | 2-1 |
| 2.2 | Unpacking and Inspection | 2-1 |
| 2.2.1 | Warranty | 2-1 |
| 2.3 | Continued Airworthiness | 2-1 |
| 2.4 | Installation Procedures | 2-2 |
| 2.4.1 | Warnings | 2-2 |
| 2.4.2 | Cautions | 2-2 |
| 2.4.3 | Cabling and Wiring | 2-2 |
| 2.4.4 | Post-Installation Checks | 2-2 |
| 2.5 | Adjustments and Connections | 2-3 |
| 2.6 | Accessories Required But Not Supplied | 2-4 |
| 2.7 | Installation Drawings | 2-4 |
| 3. | Operation | |
| 3.1 | Introduction | 3-1 |
| 3.2 | General Information | 3-1 |
| 3.3 | Controls and Indicators | 3-2 |
| 3.3.1 | Display | 3-2 |
| 3.3.2 | Keypad Controls | 3-2 |
| 3.3.3 | Annunciators | 3-4 |
| 3.4 | Name / Number Storage and Display | 3-5 |
| 3.5 | Modes of Operation | 3-5 |
| 3.5.1 | Call Mode | 3-5 |
| 3.5.2 | Recall Mode | 3-6 |
| 3.5.3 | Edit Mode | 3-6 |
| 3.6 | Keypad Function Tables | 3-8 |



PTA12-300 POTS Telephone Adapter with NVIS Display SM55-3 Installation and Operation Manual

Section 1 Description

1.1 Introduction

Information in this section consists of product description, design features and specifications for the PTA12-300 POTS Telephone Adapter with NVIS Display. All derivative product information shall be contained in the applicable manual supplement, which may be obtained from NAT as required.

Review all notes, warnings and cautions.

1.2 Product Description

The PTA12-300 POTS Telephone Adapter With NVIS Display is a keypad control and display unit for airborne telephone system applications. The PTA12-300 connects to a telephone system transceiver by a two-wire POTS (Plain Old Telephone Service) interface. The PTA12-300 can be connected to the aircraft audio controller(s) or directly to an aviation headset/handset.

Note: The PTA12-300 is designed to meet standard North American PSTN requirements, but it is not recommended or approved for landline applications.

1.3 Design Features

The PTA12-300 POTS Telephone Adapter is a compact Dzus mounted POTS telephone interface with a keypad and display. Many of the PTA12-300 functions are controlled by a microcontroller.

The functions of the PTA12-300 include speech audio circuits, hook switch, ring indication, flash, hold, redial, serial data communications, backlighting, display, speed dial, Globalstar™ SATCOM status, DTMF tone generation and ringer audio generate. The speech audio circuits include a mic input amplifier and a phones output amplifier with front panel volume control.

Hook switch control and indication is provided on the front panel. The hook switch may be controlled and its status viewed from a location remote to the PTA12-300 front panel. Ring indication is also provided on the front panel with a flashing green LED. A flash key is provided on the front panel to interrupt the hook. A hold key on the front panel mutes all audio to and from the headset and is indicated by a green LED. A redial key on the front panel automatically redials the last number called.

A two-wire POTS port achieves the interface to the satcom system transceiver. A serial port allows for data communications to satcom systems.

The front panel keypad has NVIS compliant backlighting provided.

The display is an LED dot matrix character display with brightness control.

The display is filtered for NVIS radiance requirement.

Speed dial allows numbers to be stored and recalled from memory.

Indication of Globalstar™ satcom signal strength and system availability status is provided by LED lit dead-front text on the front panel.



PTA12-300 POTS Telephone Adapter with NVIS Display SM55-3 Installation and Operation Manual

1.4 Specifications

1.4.1 Electrical Specifications

| | |
|-----------------------|--|
| <u>Power Supply</u> | Power Input Voltage with reverse, over voltage and over current protection |
| Input Voltage | |
| Normal operation | +30.3 Vdc (maximum) +27.5 Vdc (nominal) +22.0 Vdc (minimum) +18.0 Vdc (emergency) |
| Abnormal Operation | +32.2 Vdc (maximum) +27.5 Vdc (nominal) +20.5 Vdc (minimum) |
| Input Current | 0.3 Amps max. @ +27.5 Vdc |
| <u>Lighting</u> | 1.0 mA max. @ +27.5 Vdc 1.0 mA max. @ +5.0 Vdc |
| <u>Input Signals</u> | |
| Microphone | 250 mVrms rated input level, amplified dynamic |
| Impedance | 150 Ohm \pm 10% |
| Circuitry Type | Single Ended |
| Mic Bias | +13 \pm 0.5 Vdc (selectable via switch) |
| Key In | Used to remotely control the Hook function. Momentarily pull to Power Ground for a period greater than 500 ms to activate the Hook function. Momentarily open circuit or apply voltage greater than 26 Vdc for a period greater than 500 ms to set the Hook to inactive. Optically isolated and requires 10 mA max source current. |
| <u>Output Signals</u> | |
| Rated Level | 20 dBm \pm 3 dB into 600 or 150 Ohms @ 100mW |
| Circuitry Type | Differential |
| Frequency Response | \leq 3 dB roll-off from 350 Hz to 3 kHz |
| Distortion | \leq 5% THD @ rated power output |
| Audio Noise | \leq -50 dB from rated output (no signal) |



PTA12-300 POTS Telephone Adapter with NVIS Display SM55-3 Installation and Operation Manual

| | |
|------------------------------|---|
| Available Audio | RX audio, Sidetone, DTMF sidetone Ringing tone (enabled or disabled externally) |
| RX Audio | See RX Audio in the Bidirectional Signals section for rated output level |
| Sidetone | Rated mic input yields rated phones output with rated TX mic audio set on TIP/RING and both front panel VOL control and S/T level potentiometer set to max. |
| DTMF Sidetone | -9 dBm \pm 3 dB into 600 Ohms |
| Ringer Audio | 14 dBm \pm 2 dB into 600 Ohms with ringer audio enabled on the Phones Output (RGR internal switch set to DOWN) and 2.5 Vrms setup on the Ringer Audio Output Ringer audio present (based on ringing cadence) |
| Level | 2.5 \pm 0.3 Vrms (typical) 3.6 \pm 0.4 Vrms (max) into 600Ohms |
| Circuitry Type | Single Ended |
| Ringer Drive | Pulled to Power Ground when ringer is active (based on ringing cadence) Open collector, 250mA max sink current @ +28 Vdc Over-current and over-voltage protected |
| Key Out | When Key In is wired for Hook latching or is tied to Power Ground, this output is pulled to Power Ground when the Hook Switch is active Solid state relay output, optically isolated, 100mA max sink current @ +28 Vdc |
| <u>Bidirectional Signals</u> | |
| POTS (2 wire) | Polarity insensitive and current limited |
| On-hook Condition | |
| DC Voltage | Withstands \pm 70 Vdc max. |
| Resistance | 10M to 15M Ohms |
| Ringing Condition | |
| Impedance | 10k to 15k Ohms @ 25 Hz Active when ringing signal on tip/ring >30 Vrms @ 25 Hz Inactive when ringing signal on tip/ring <10 Vrms @ 25 Hz Accepts square or sinusoidal ringing functions Withstands 120 Vrms (max), 25 Hz sinusoidal ringing function |



PTA12-300 POTS Telephone Adapter with NVIS Display SM55-3 Installation and Operation Manual

Off-hook Condition

| | |
|--|---|
| Impedance | 600 Ohms @ 1kHz (nominal) |
| Circuitry Type | Balanced |
| DC Loop Current | 25 mA (typical) to 130 mA (max) |
| DC Voltage | ≤ 9.0 Vdc @ 25 mA loop current |
| Frequency Response | ≤ 3 dB roll-off from 350 Hz to 3 kHz |
| Distortion | $\leq 5\%$ THD |
| Audio Noise | ≤ -50 dB from rated output (no signal) |
| Available Audio | TX Audio, RX Audio |
| TX Audio (Mic Input to tip/ring) | -1 dBm ± 1 dB into 600 Ohms with $< 5\%$ THD (test condition: 250 mVrms @ 1kHz into Mic input, Mic level potentiometer set to max.) |
| RX Audio (Typ expected audio level) | -20 to 0 dBm 400 mVrms @ 1kHz RX audio on TIP/RING yields rated phones output with both front panel VOL control and RX level potentiometer set to max. |
| DTMF Signaling | Standard DTMF frequencies used |
| Frequency Tolerance | $\pm 1.5\%$ |
| Supported Codes | 0 – 9, *, # |
| DTMF TX on tip/ring | -2.2 dBm ± 1.0 dB into 600 Ohms (DTMF level potentiometer set to max.) |

Serial Port

| | |
|--------------|--------------------------------|
| | RS232 protocol, RX, TX and GND |
| Baud Rate | 19200 |
| Frame Size | 8 bits |
| Parity | none |
| Stop Bits | 1 |
| Flow Control | Not available |



PTA12-300 POTS Telephone Adapter with NVIS Display SM55-3 Installation and Operation Manual

| | |
|----------------------------------|--|
| <u>Annunciators</u> | HK, HLD, LNK and SYS, green LED with dead-front text |
| HK (Hook Status / Ringer Active) | |
| On Hook | LED off |
| Off Hook | LED on |
| Ringer On | LED flashes (0.33 second period @ 50% duty cycle) |
| HLD (Hold Status) | |
| On Hold | LED on |
| Off Hold | LED off |
| LNK (satcom link) | |
| Link Established | LED on |
| Link Down | LED off |
| SYS (satcom system) | |
| Available for Voice | LED on |
| Busy | LED off |

1.4.2 Physical Specifications

| | |
|-------------|--|
| Height | 1.52" (38.6 mm) |
| Depth | 4.17" (105.9 mm) max. behind panel |
| Width | 5.77" (146.6 mm) in front of panel 4.82" (122.4 mm) behind panel |
| Weight | 0.80 lbs (0.36 kg) |
| Mounting | Dzus Mounting (four fasteners) |
| Front Panel | Aluminum with polycarbonate label and elastomeric keypad Silicone rubber, tactile push-buttons backlit by amber LEDs Front panel bezel is not backlit |
| Display | 16 5x7 pixel characters with NVIS green B-friendly polarized filter NVIS green B-compliant radiance and luminance per MIL-STD-3009 Chromaticity non-compliant per MIL-STD-3009. |



PTA12-300 POTS Telephone Adapter with NVIS Display SM55-3 Installation and Operation Manual

| | |
|------------------|--|
| Annunciator LEDs | NVIS green B filtered and covered by a polycarbonate lens Meets daylight readability per MIL-STD-411 Sec 5.1.3.3 Annunciators with filters are NVIS Green B compliant per MIL-STD-3009 |
| Backlighting | NVIS Green B compliant per MIL-STD-3009. |
| Material/Finish | Chassis & cover are 5052-H32 brushed aluminum with chromate conversion finish Front panel aluminum bezel is 6061-T6 with black paint and matte clear coat over chromate conversion finish |
| Connectors | One male filtered 25 pin D-submin with Positronics V5 locking tabs |

1.4.3 Environmental Specifications

| | |
|-------------|---|
| Temperature | -20 to +55°C (operating) -55 to +85°C (survival) |
| Altitude | 50,000 feet max. |
| Humidity | > 95% |
| Vibration | DO-160D Cat. [(SBM)(UF)] |

Qualification of the PTA12-100 POTS Telephone Adapter with Display was completed in accordance with DO-160D Env. Cat. A1/D1-BAB[(SBM)(UF)]XXXXXXZBABB[UUX]MXXXX.

Note: Tested to DO-160D pre-change 1 and 2.

Section 1 ends



PTA12-300 POTS Telephone Adapter with NVIS Display SM55-3 Installation and Operation Manual

Section 2 Installation

2.1 Introduction

Information in this section consists of unpacking and inspection procedures, installation procedures, post-installation checks and installation drawings for the PTA12-300 POTS Telephone Adapter with NVIS Display.

Review all notes, warnings and cautions.

2.2 Unpacking and Inspection

Unpack the equipment carefully and locate the warranty card. Inspect the unit visually for damage due to shipping and report all such claims immediately to the carrier involved. Check that all items listed below are present before proceeding and report any shortage immediately to your supplier:

- Warranty Card
- Operators Manual
- Certificate of Conformity or Release Certification

2.2.1 Warranty

All Northern Airborne Technology Ltd. products are warranted for 2 years from date of installation by an authorized Northern Airborne Technology Ltd. dealer, to be free of defects in workmanship or performance. This warranty covers all materials and labour, but is exclusive of any transport to deliver the defective unit to and from Northern Airborne Technology Ltd. or its designated warranty repair center, or any labour to remove or re-install the defective unit in the aircraft. Contact Northern Airborne Technology Ltd. for any questions regarding this warranty, its applicability to your units and/or for return authorization. Northern Airborne Technology Ltd. is the final arbitrator concerning warranty administration. Units which have been physically damaged, burned, immersed in water or otherwise abused beyond the scope of normal use will not be considered for warranty. **WARRANTY IS VOID UNLESS THE PRODUCT IS INSTALLED BY AN AUTHORIZED NORTHERN AIRBORNE TECHNOLOGY LTD. DEALER.** Product for which a warranty card is not returned shall be warranted from date of manufacture.

2.3 Continued Airworthiness

Maintenance of the PTA12-300 POTS Telephone Adapter with NVIS Display is 'on condition' only. Periodic maintenance of this product is not required.



PTA12-300 POTS Telephone Adapter with NVIS Display SM55-3 Installation and Operation Manual

2.4 Installation Procedures

2.4.1 Warnings

WARNING:
High volume settings can cause hearing damage.
Set the headset volume control to the minimum volume setting prior to conducting tests, and slowly increase the headset volume to a comfortable listening level.

2.4.2 Cautions

CAUTION:
Do not take a ground from the instrument panel or similar location that shares a ground return with a turn and bank, horizon or other motor driven instrument. This may cause the PTA12-300 unit to pick up the sound of the motor as ground loop interference.

2.4.3 Cabling and Wiring

All wire shall be selected in accordance with the original aircraft manufacturer's Maintenance Instructions or AC43.13-1B Change 1, Paragraphs 11-76 through 11-78. Unshielded wire types shall qualify to MIL-W-22759 as specified in AC43.13-1B Change 1, Paragraphs 11-85, 11-86, and listed in Table 11-11. For shielded wire applications, use Tefzel MIL-C-27500 shielded wire with solder sleeves (for shield terminations) to make the most compact and easily terminated interconnect. Follow the connector map in Section 2.7 as required.

Allow 3" from the end of the shielded wiring to the shield termination to allow the connector hood to be easily installed. Reference the interconnect drawing in Section 2.7 for shield termination details.

Maintain wire segregation and route wiring in accordance with the original aircraft manufacturers Maintenance Instructions.

Unless otherwise noted, all wiring shall be a minimum of 22 AWG, except power and ground lines, which shall be a minimum of 20 AWG. Reference the Interconnect drawing for additional specifications. Check that the ground connection is clean and well secured, and that it shares no path with any electrically noisy aircraft accessories such as blowers, turn and bank instruments or similar loads.

2.4.4 Post-Installation Checks

2.4.4.1 Voltage/Resistance Checks

Do not attach the PTA12-300 until the following conditions are met.

Check the following:

- a) Check P101, pin <1> for +28 Vdc relative to ground.
- b) Check P101, pin <3> for +28 Vdc OR pin <4> for +5 Vdc relative to ground.
- c) Check P101, pins <14>, <16> and <19> for continuity to ground (less than 0.5Ω).



PTA12-300 POTS Telephone Adapter with NVIS Display SM55-3 Installation and Operation Manual

2.4.4.2 Power On Checks

- Notes:**
1. PTA12-300 functionality is highly dependant on the airborne telephone system interface. Check proper operation of the telephone transceiver, and check that the transceiver has an activated telephone line.
 2. Where the PTA12-300 is connected to an existing audio system, check that the PTA12-300 is properly selected when performing audio checks.

Power up the aircraft's systems and confirm normal operation of all functions of the PTA12-300. Refer to Section 3 (Operation) for specific operational details.

- a) Initiate a call to a valid telephone number and verify the operation for HOOK, HOLD, DTMF keys (0 – 9, *, #) and VOL. Re-initiate the call using REDIAL. Test the FLASH function (where applicable) while in the off-hook state (active).
- b) Place the PTA12-300 in the on-hook (inactive) state, and have another party call the line connected to the PTA12. Confirm proper RINGER, HOOK and HOLD operation.
- c) To verify proper operation, all functions and levels shall be checked in-flight.

Upon satisfactory completion of all performance checks, make all required log book entries, electrical load, weight and balance amendments and other documentation as required by your local regulatory agency before releasing the aircraft for service.

2.5 Adjustments and Connections

The following adjustments are accessible through holes in the side of the unit shown in Figure 1.

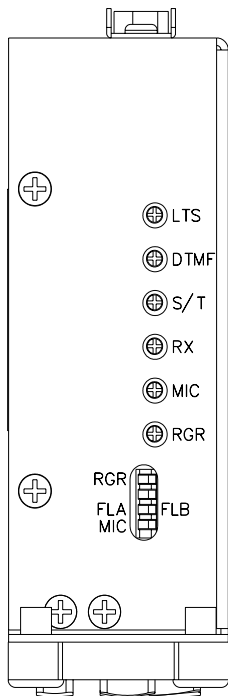

Figure 1: Adjustments

Rotating the trimpots cw will increase the level of the related output and ccw will decrease it.

Internal Trimpot Adjustments

- LTS** adjusts keypad backlighting level from min to max
- DTMF** adjusts DTMF level on POTS interface
- S/T** adjusts sidetone level
- RX** adjusts receive level on phones output
- MIC** adjusts mic level on POTS interface
- RGR** adjusts ringer level on both ringer audio and phones output

Internal Switch Settings

- RGR** (ringer select)
 - on [down] ringer audio available on both phones and ringer audio outputs
 - off [up] ringer audio only available on ringer audio output
- FLA / FLB** (hook flash)
 - select FLA flash = 90 ms ±40 ms
 - select FLB flash = 600 ms ±100 ms
- MIC** (mic bias)
 - on [down] mic bias supplied by PTA12
 - off [up] mic bias not supplied



PTA12-300 POTS Telephone Adapter with NVIS Display SM55-3 Installation and Operation Manual

2.6 Accessories Required But Not Supplied

Installation kit p/n D25SV-IKC (crimp) is required to complete the installation. The kit consists of the following:

| Quantity | Description | NAT Part No. |
|----------|---------------------------|--------------|
| 1 | D-min 25 Socket Housing | 20-21-025 |
| 25 | MS Crimp Socket | 20-26-901 |
| 1 | 25 Pin JVL Hood/Locklever | 20-29-250 |

2.7 Installation Drawings







Insert into the following list all applicable Installation Drawings (including a minimum of 403, 405, 922 or 952 and if available the 404, 521 and 905). See following example.

| DOCUMENT | REV. | DESCRIPTION | TYPE |
|-------------------|------|--|-------------------------|
| PTA12-300 | | | |
| PTA12\300\403-0 | 1.00 | POTS Telephone Adapter with NVIS Display | Interconnect |
| PTA12\300\403-1 | 1.00 | POTS Telephone Adapter with NVIS Display | Interconnect |
| PTA12\300\403-2 | 1.00 | POTS Telephone Adapter with NVIS Display | Interconnect |
| PTA12\300\403-3 | 1.00 | POTS Telephone Adapter with NVIS Display | Interconnect |
| PTA12\300\403-4 | 1.00 | POTS Telephone Adapter with NVIS Display | Interconnect |
| PTA12\300\405-0 | 1.00 | POTS Telephone Adapter with NVIS Display | Connector Map |
| PTA12\300\905-0 | 1.00 | POTS Telephone Adapter with NVIS Display | Faceplate |
| PTA12\300\922-0 | 1.10 | POTS Telephone Adapter with NVIS Display | Mechanical Installation |
| STX100-000 | | | |
| STX100\000\403-6 | 1.00 | STX100 GLOBALSTAR™ Satphone Receiver | Interconnect |
| STX100\000\403-7 | 1.00 | STX100 GLOBALSTAR™ Satphone Receiver | Interconnect |

Section 2 ends following the above documents

PTA12-300 INSTALLATION NOTES



NOTES:

1. ALL WIRES SHOULD BE 22 AWG UNLESS OTHERWISE SPECIFIED. ALL UNSHIELDED WIRE SHALL BE SELECTED IN ACCORDANCE WITH AC43.13-1B CHANGE 1, PARAGRAPHS 11-76 THROUGH 11-78. WIRE TYPES SHOULD BE TO MIL-W-22759 AS SPECIFIED IN AC43.13-1B CHANGE 1, PARAGRAPHS 11-85, 11-86 AND LISTED IN TABLE 11-11. ALL SHIELDED WIRE/CABLE SHOULD BE IN ACCORDANCE WITH MIL-C-27500.
-  MIC LO MUST BE GROUNDED AT AUDIO PANEL.
-  PULLED TO POWER GROUND WHEN ACTIVE. +28 VDC MAX @ 250mA MAX.
-  ONLY +28VDC LIGHTS OR +5VDC LIGHTS MAY BE USED AT ONE TIME.
-  PTA12 PHONES OUTPUT IS TRANSFORMER COUPLED (BALANCED); 'LO' WIRE REQUIRES TERMINATION.
-  TIE TO A/C GROUND TO ENABLE REMOTE HOOK ANNUNCIATION.
-  PULLED TO POWER GROUND WHEN ACTIVE AND J101 PIN 19 TIED TO A/C GROUND. +28VDC MAX @ 100mA MAX.
8. THIS DRAWING APPLIES TO THE FOLLOWING MODELS: PTA12-300

DEFINITIONS:

- N/C: NO CONNECTION. THE PIN IS NOT CONNECTED TO ANYTHING INTERNALLY, AND THEREFORE SHALL HAVE NO CONNECTION EXTERNALLY.
- RESERVED: MAY BE CONNECTED AND USED IN THE FUTURE. THE CIRCUITRY MAY BE PRESENT OR ADDED TO ACTIVATE THE FUNCTION. THE PIN MAY BE USED FOR TEST PURPOSES. THERE IS NO EXTERNAL CONNECTION.

CONFIDENTIAL AND PROPRIETARY TO NAT LTD.

| | | | | | | |
|----------|---|--|--|--------------------------|--------------|--------------|
| DESIGNED | SRK |  NAT NORTHERN AIRBORNE TECHNOLOGY LTD. | | | | |
| DRAWN | MWS | | | | | |
| DATE | MAY 18/05 | TITLE | | | | |
| CHECKED | NAT 205 | NAT 255 | POTS TELEPHONE ADAPTER WITH NVIS DISPLAY | | | |
| APPROVED |  | SIZE A | CAGE CODE 3AB01 | PART NO. PTA12-300 | REV. 1.00 | SHEET 1/5 |
| FILE | 403-0.DWG | DWG. TYPE | INTERCONNECT | DWG. NO. PTA12\300\403-0 | | |

PTA12-300
POTS TELEPHONE
ADAPTER

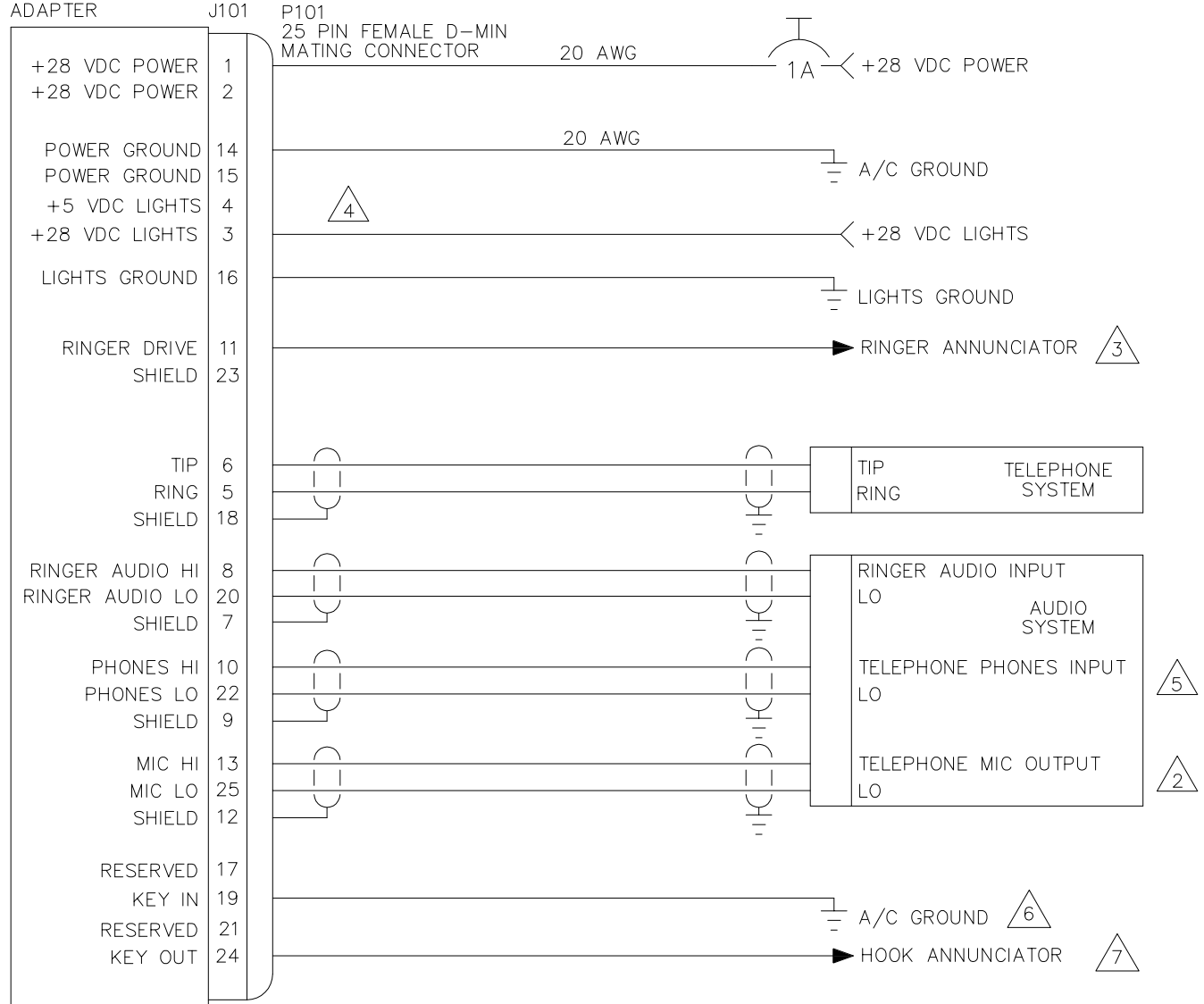

CONFIDENTIAL AND PROPRIETARY TO NAT LTD.

| | | | | | | |
|----------|-------------------|--|--------------|-----------|-----------------|---|
| DESIGNED | SRK |  NAT NORTHERN AIRBORNE TECHNOLOGY LTD. | | | | |
| DRAWN | MWS | | | | | |
| DATE | MAY 18/05 | TITLE | | | | POTS TELEPHONE ADAPTER WITH NVIS DISPLAY |
| CHECKED | NAT 205 | NAT 255 | | | | |
| APPROVED | NAT 114 | SIZE | CAGE CODE | PART NO. | REV. | SHEET |
| | | A | 3AB01 | PTA12-300 | 1.00 | 2/5 |
| FILE | 403-0.DWG | DWG. TYPE | INTERCONNECT | DWG. NO. | PTA12\300\403-1 | |

PTA12-300
POTS TELEPHONE
ADAPTER

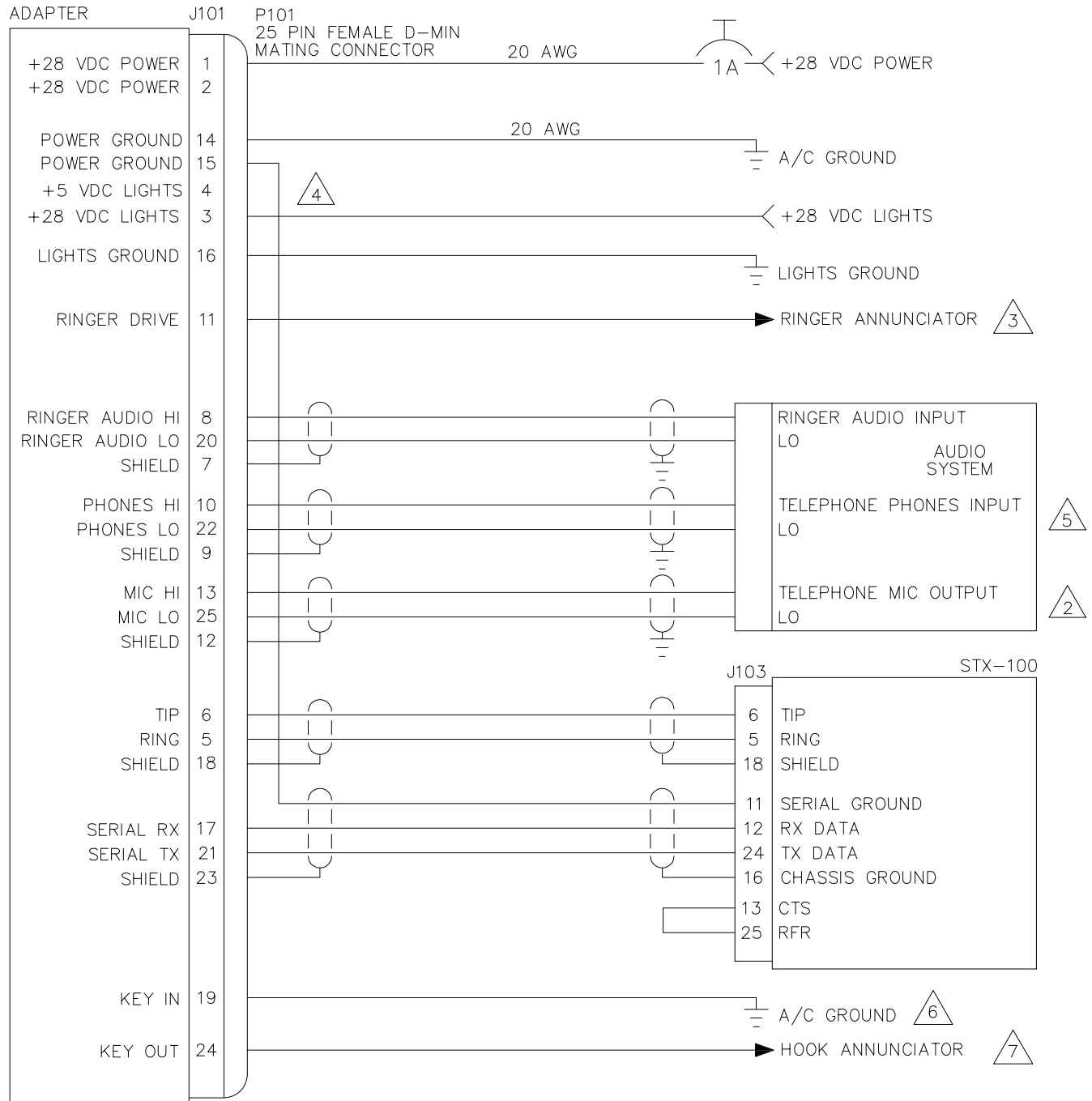

CONFIDENTIAL AND PROPRIETARY TO NAT LTD.

| | | | | | | |
|----------|----------------|--|--|-----------|-----------------|-------|
| DESIGNED | SRK |  NAT NORTHERN AIRBORNE TECHNOLOGY LTD. | | | | |
| DRAWN | MWS | | | | | |
| DATE | MAY 18/05 | TITLE | | | | |
| CHECKED | NAT 205 | NAT 255 | POTS TELEPHONE ADAPTER WITH NVIS DISPLAY, STX100 OPTION | | | |
| APPROVED | NAT 114 | SIZE | CAGE CODE | PART NO. | REV. | SHEET |
| | | A | 3AB01 | PTA12-300 | 1.00 | 3/5 |
| FILE | 403-0.DWG | DWG. TYPE | INTERCONNECT | DWG. NO. | PTA12\300\403-2 | |

PTA12-300
POTS TELEPHONE
ADAPTER

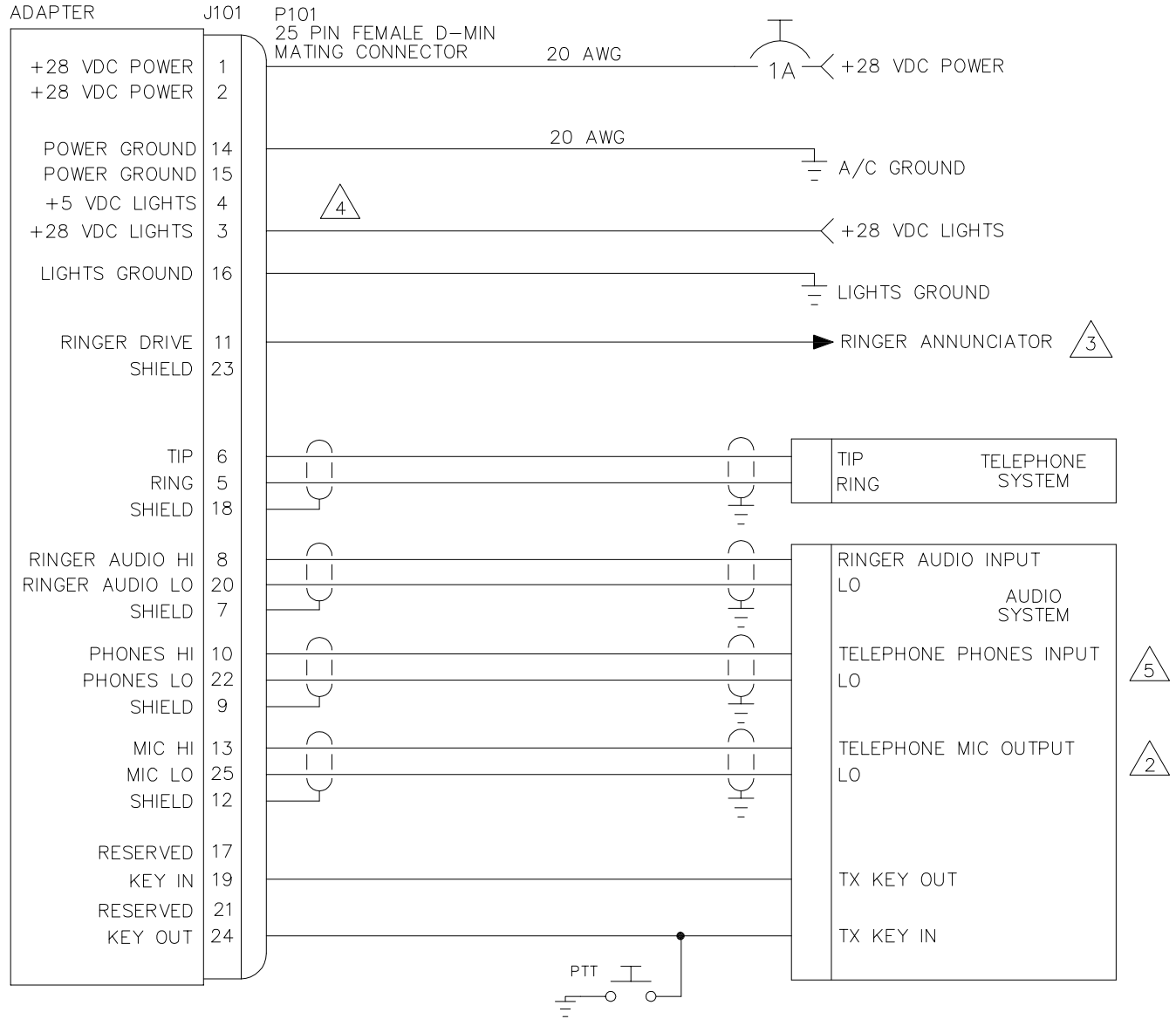

CONFIDENTIAL AND PROPRIETARY TO NAT LTD.

| | | | | | | |
|----------|----------------|--|--------------|--------------------------|------|--|
| DESIGNED | SRK |  NAT NORTHERN AIRBORNE TECHNOLOGY LTD. | | | | |
| DRAWN | MWS | | | | | |
| DATE | MAY 18/05 | TITLE | | | | POTS TELEPHONE ADAPTER WITH NVIS DISPLAY, REMOTE HOOK CONTROL OPTION |
| CHECKED | NAT 205 | NAT 255 | | | | |
| APPROVED | NAT 114 | SIZE | CAGE CODE | PART NO. | REV. | SHEET |
| | | A | 3AB01 | PTA12-300 | 1.00 | 4/5 |
| FILE | 403-0.DWG | DWG. TYPE | INTERCONNECT | DWG. NO. PTA12\300\403-3 | | |

PTA12-300
POTS TELEPHONE
ADAPTER

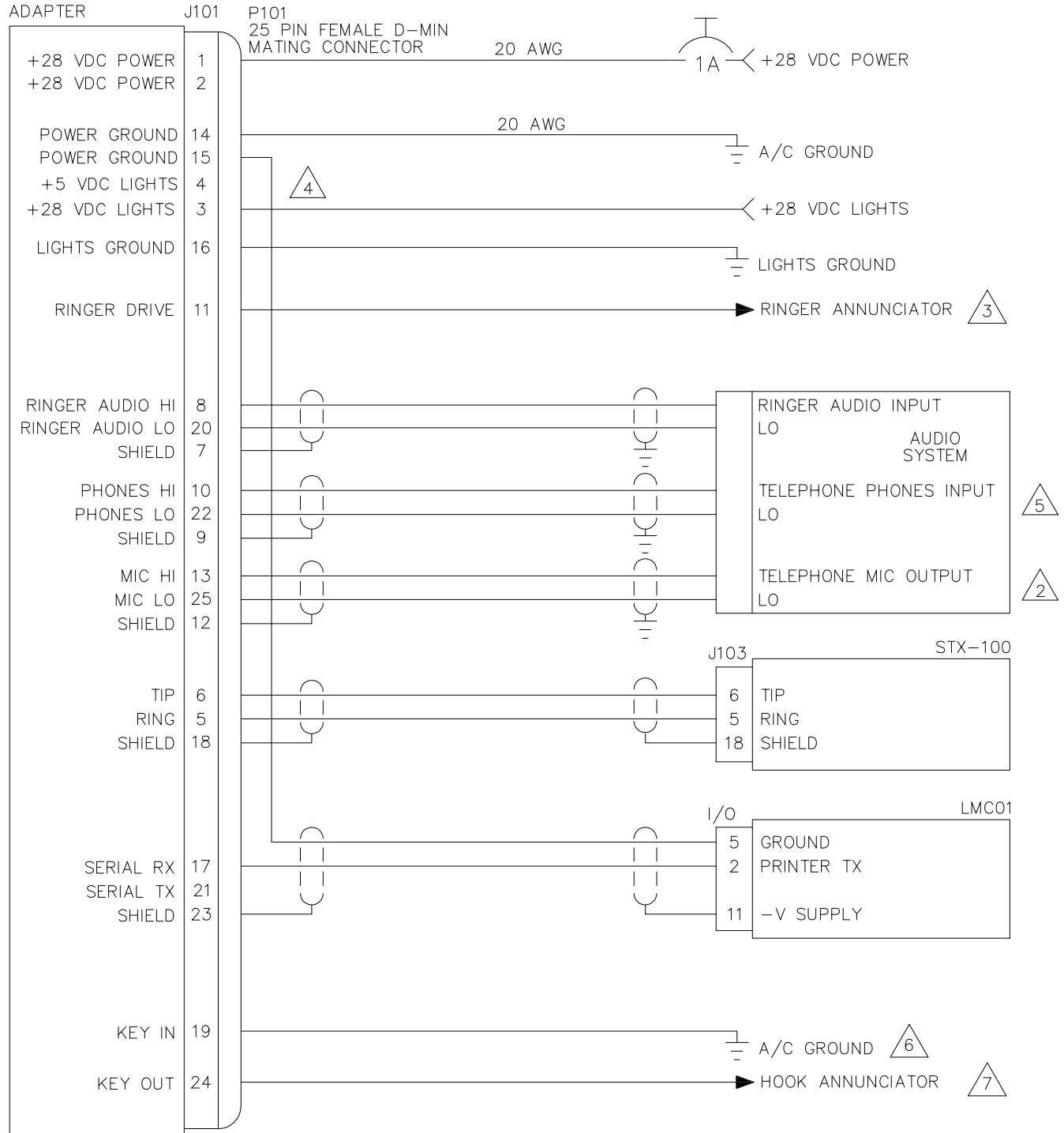

CONFIDENTIAL AND PROPRIETARY TO NAT LTD.

| | | | | | | |
|----------|-------------------------------|--|--------------------|--------------------------|--------------|--------------|
| DESIGNED | SRK |  NAT NORTHERN AIRBORNE TECHNOLOGY LTD. | | | | |
| DRAWN | MWS | | | | | |
| DATE | MAY 18/05 | TITLE POTS TELEPHONE ADAPTER WITH NVIS DISPLAY, STX100/LMC01 OPTION | | | | |
| CHECKED | NAT 205 NAT 255 | | | | | |
| APPROVED | NAT 114 | SIZE A | CAGE CODE 3AB01 | PART NO. PTA12-300 | REV. 1.00 | SHEET 5/5 |
| FILE | 403-0.DWG | DWG. TYPE INTERCONNECT | | DWG. NO. PTA12\300\403-4 | | |

MATING CONNECTOR
25 PIN FEMALE D-MIN

P101

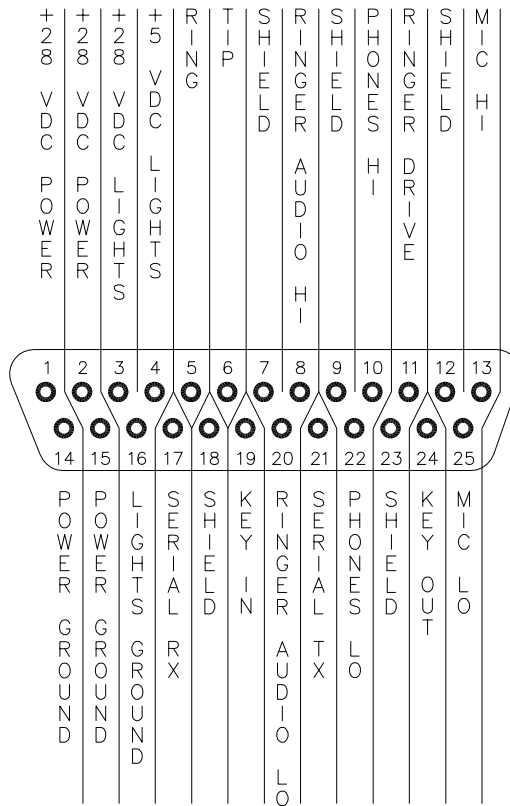

VIEW IS FROM REAR OF AIRFRAME CONNECTOR.

NOTES:



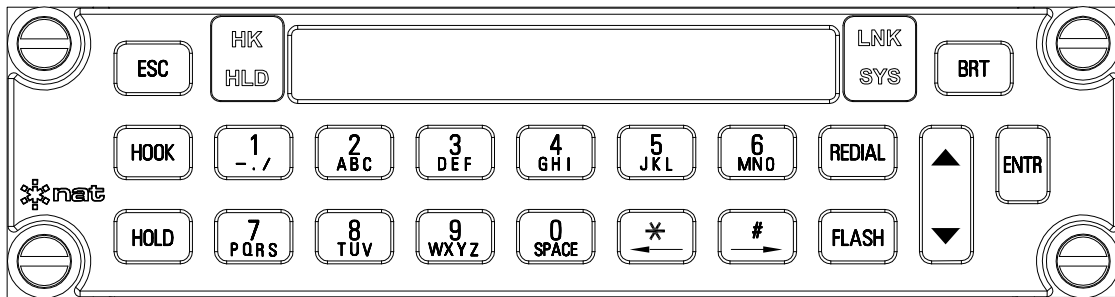

- THIS DRAWING APPLIES TO THE FOLLOWING MODELS:
PTA12-300

CONFIDENTIAL AND PROPRIETARY TO NAT LTD.

| | | | | | | |
|----------|----------------|--|---------------|--------------------------|------|-------|
| DESIGNED | SRK |  NAT NORTHERN AIRBORNE TECHNOLOGY LTD. | | | | |
| DRAWN | MWS | | | | | |
| DATE | MAY 18/05 | TITLE | | | | |
| CHECKED | NAT 255 | POTS TELEPHONE ADAPTER WITH NVIS DISPLAY | | | | |
| APPROVED | NAT 114 | SIZE | CAGE CODE | PART NO. | REV. | SHEET |
| | | A | 3AB01 | PTA12-300 | 1.00 | 1/1 |
| FILE | 405-0.DWG | DWG. TYPE | CONNECTOR MAP | DWG. NO. PTA12\300\405-0 | | |



CONFIDENTIAL AND PROPRIETARY TO NAT LTD.

| | | | | | | | |
|---|--|--|-----------------------|--------------------|-----------------------|--------------|--------------|
| DESIGNED | SRK |  NAT NORTHERN AIRBORNE TECHNOLOGY LTD. | | | | | |
| DRAWN | MWS | | | | | | |
| DATE | SEP 01/05 | TITLE POTS TELEPHONE ADAPTER WITH NVIS DISPLAY | | | | | |
| CHECKED | <table border="1"> <tr> <td>NAT 205</td> <td>NAT 255</td> </tr> </table> | | | | | | NAT 205 |
| NAT 205 | NAT 255 | | | | | | |
| APPROVED | <table border="1"> <tr> <td>  </td> <td>SIZE A</td> <td>CAGE CODE 3AB01</td> <td>PART NO. PTA12-300</td> <td>REV. 1.00</td> <td>SHEET 1/1</td> </tr> </table> |  | SIZE A | CAGE CODE 3AB01 | PART NO. PTA12-300 | REV. 1.00 | SHEET 1/1 |
|  | SIZE A | CAGE CODE 3AB01 | PART NO. PTA12-300 | REV. 1.00 | SHEET 1/1 | | |
| FILE | 905-0.DWG | DWG. TYPE | FACEPLATE | DWG. NO. | PTA12\300\905-0 | | |

| REVISIONS | | | |
|-----------|--|-----------|-----|
| REV | DESCRIPTION | DATE | BY |
| 1.01 | DOCCR02861 - CHANGED LABELS AND LABEL LOCATIONS. | JUL 17/09 | TAT |
| 1.10 | DOCCR02927 - UPDATED TO WED LABELS. | APR 13/10 | MWS |

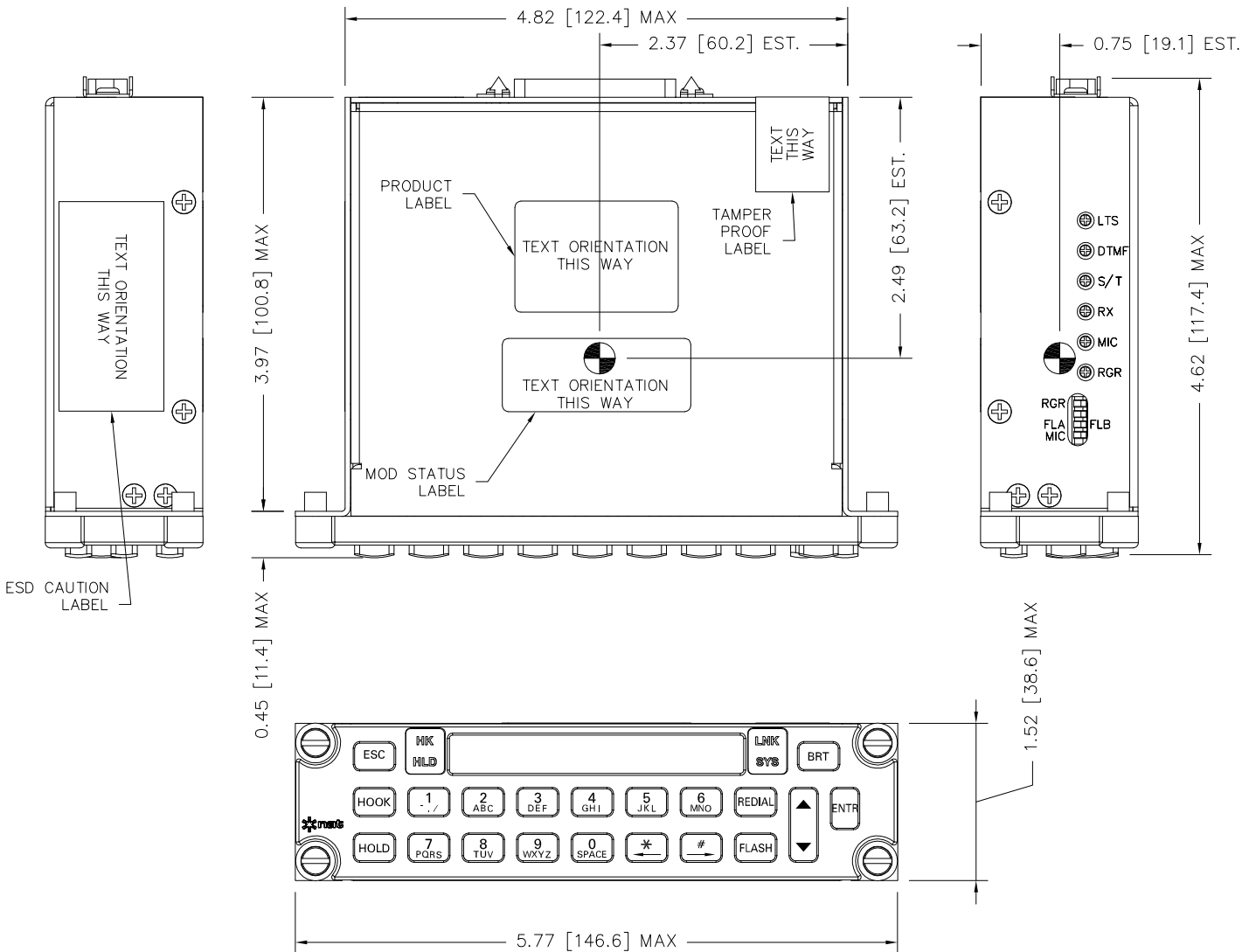
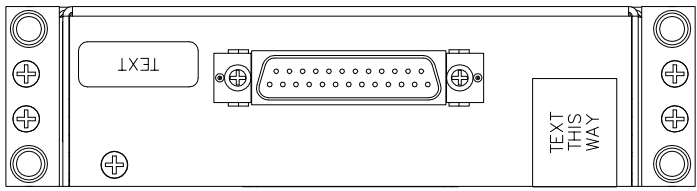

- NOTES:
- DIMENSIONING AND TOLERANCING IN ACCORDANCE WITH ASME Y14.5M-1994
 - THIS DRAWING APPLIES TO THE FOLLOWING MODELS: PTA12-100, PTA12-104
 - WEIGHT: 0.68 lbs. (0.31 Kg) MIN
0.80 lbs. (0.36 Kg) MAX

CENTER OF GRAVITY

CONFIDENTIAL AND PROPRIETARY TO NAT LTD.

| | | | | | | | |
|--|----------|----------------|---|--------------------|-----------|-----------------|-------|
| DIMENSIONS ARE INCHES [mm] THIRD ANGLE PROJECTION | DESIGNED | SRK | NAT NORTHERN AIRBORNE TECHNOLOGY LTD. | | | | |
| | DRAWN | MWS | | | | | |
| MASS: SEE NOTE 3. | DATE | SEP 01/05 | TITLE POTS TELEPHONE ADAPTER WITH NVIS DISPLAY | | | | |
| | CHECKED | NAT 255 | | | | | |
| MATERIAL: | APPROVED | NAT 114 | SIZE | CAGE CODE | PART NO. | REV. | SHEET |
| FINISH: | FILE | 922-0.DWG | A | 3AB01 | PTA12-300 | 1.10 | 1/1 |
| | | | DWG. TYPE | MECH. INSTALLATION | DWG. NO. | PTA12\300\922-0 | |

NOTES:



1. ALL WIRES SHOULD BE 22 AWG UNLESS OTHERWISE SPECIFIED. ALL UNSHIELDED WIRE SHALL BE SELECTED IN ACCORDANCE WITH AC43.13-1B CHANGE 1, PARAGRAPHS 11-76 THROUGH 11-78. WIRE TYPES SHOULD BE TO MIL-W-22759 AS SPECIFIED IN AC43.13-1B CHANGE 1, PARAGRAPHS 11-85, 11-86 AND LISTED IN TABLE 11-11. ALL SHIELDED WIRE/CABLE SHOULD BE IN ACCORDANCE WITH MIL-C-27500.
- △2 'DM' PINS TO BE USED BY GLOBALSTAR/QUALCOMM FOR AUTOMATED TEST AND DIAGNOSTICS.
- △3 ON/OFF CONTROL MUST BE GROUNDED TO ACTIVATE UNIT. CONTROL LINE CAN ALSO BE SOURCED FROM REMOTE SWITCH AND/OR OUTPUT FROM ASSOCIATED CONTROL UNIT, AS APPLICABLE.
- △4 COAXIAL CABLE TYPE TO BE SELECTED BASED ON INSTALLATION REQUIREMENTS. REFER TO SECTION 2.3.4 OF STX100 INSTALL/OPERATION MANUAL.
- △5 GROUNDED NOT MORE THAN 1 METER FROM UNIT.
- △6 TX FILTER IS NOT DIRECTIONAL.
- △7 MIC LO MUST BE GROUNDED AT AUDIO PANEL.
- △8 PULLED TO POWER GROUND WHEN ACTIVE. +28 VDC MAX @ 250mA MAX.
- △9 ONLY +28VDC LIGHTS OR +5VDC LIGHTS MAY BE USED AT ONE TIME.
- △10 PTA12 PHONES OUTPUT IS TRANSFORMER COUPLED (BALANCED); 'LO' WIRE REQUIRES TERMINATION.
- △11 TIE TO A/C GROUND TO ENABLE REMOTE HOOK ANNUNCIATION.
- △12 PULLED TO POWER GROUND WHEN ACTIVE AND J101 PIN 19 TIED TO A/C GROUND. +28VDC MAX @ 100mA MAX.
13. THIS DRAWING APPLIES TO THE FOLLOWING MODELS: PTA12-100
- △14 SHIELD RETURNS SHOULD BE GROUNDED TO CONNECTOR BACK SHELL (METAL TYPE), IF USED. OTHERWISE, GROUND TO LOCAL AIRFRAME GROUND.

DEFINITIONS:

N/C: NO CONNECTION. THE PIN IS NOT CONNECTED TO ANYTHING INTERNALLY, AND THEREFORE SHALL HAVE NO CONNECTION EXTERNALLY.

RESERVED: MAY BE CONNECTED AND USED IN THE FUTURE. THE CIRCUITRY MAY BE PRESENT OR ADDED TO ACTIVATE THE FUNCTION. THE PIN MAY BE USED FOR TEST PURPOSES. THERE IS NO EXTERNAL CONNECTION.

CONFIDENTIAL AND PROPRIETARY TO NAT LTD.

| | | | | | | |
|----------|---|--|--|---------------------------|------|-------|
| DESIGNED | JM |  NAT NORTHERN AIRBORNE TECHNOLOGY LTD. | | | | |
| DRAWN | TAT | | | | | |
| DATE | APR 20/05 | TITLE | | | | |
| CHECKED | NAT 205 | NAT 255 | STX100 GLOBALSTAR™ SATPHONE TRANSCEIVER | | | |
| APPROVED |  | SIZE | CAGE CODE | PART NO. | REV. | SHEET |
| | | A | 3AB01 | STX100-000 | 1.00 | 1/2 |
| FILE | 403-6.DWG | DWG. TYPE | INTERCONNECT | DWG. NO. STX100\000\403-6 | | |

PTA12-100
POTS TELEPHONE
ADAPTER

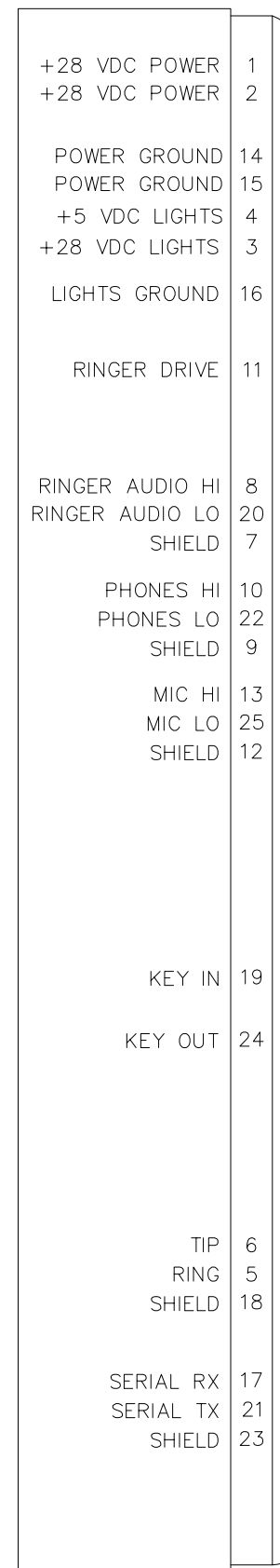

P101
25 PIN FEMALE D-MIN
MATING CONNECTOR

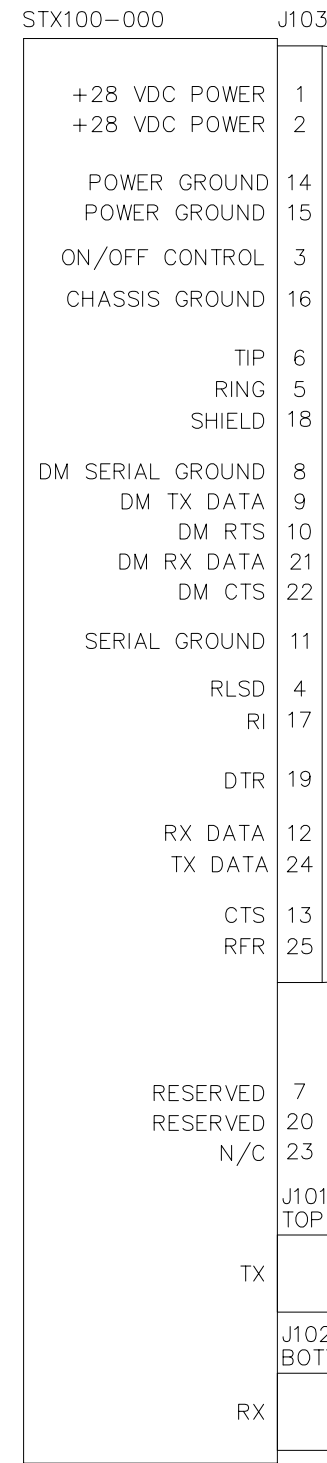
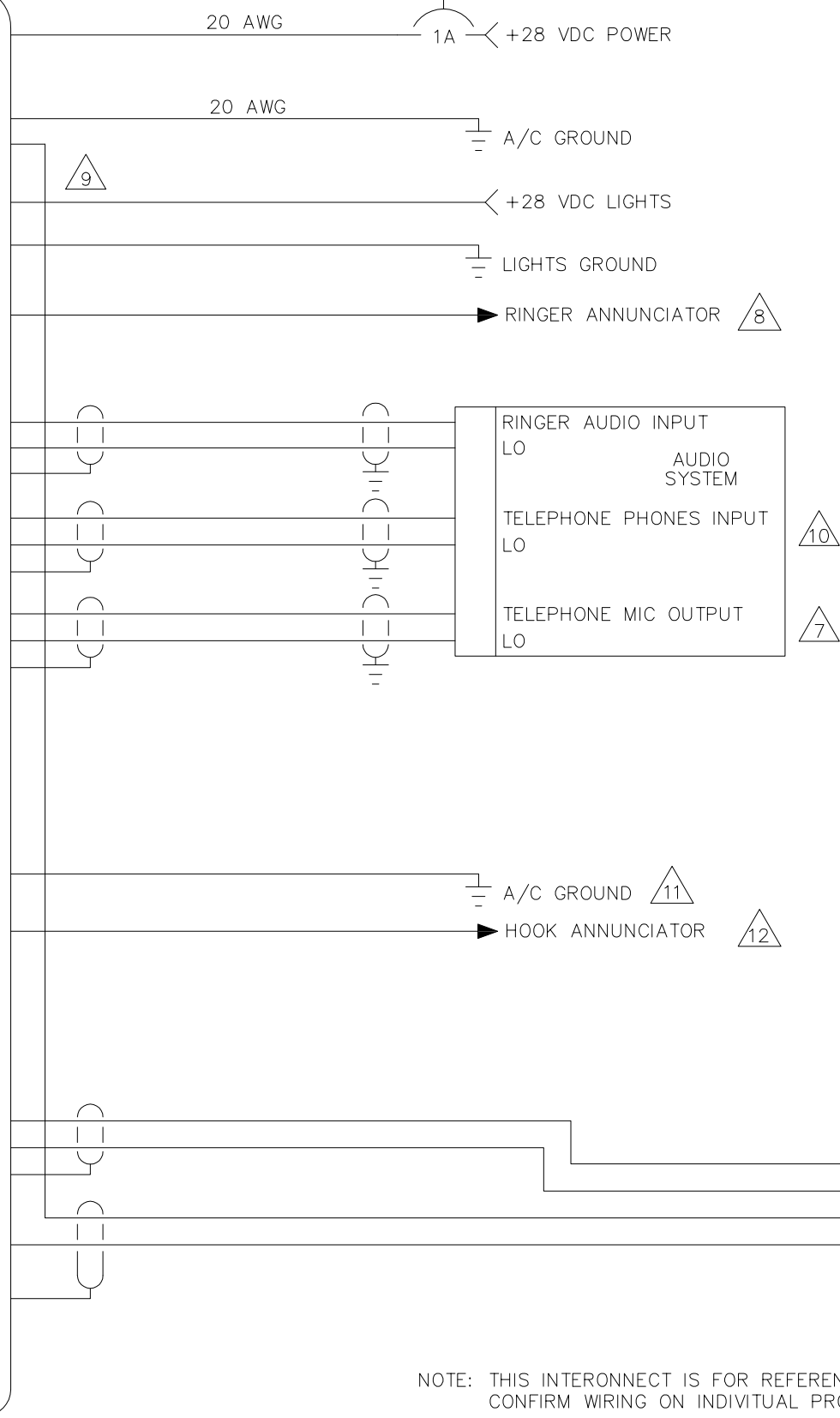

P103
25 PIN FEMALE D-MIN
MATING CONNECTOR

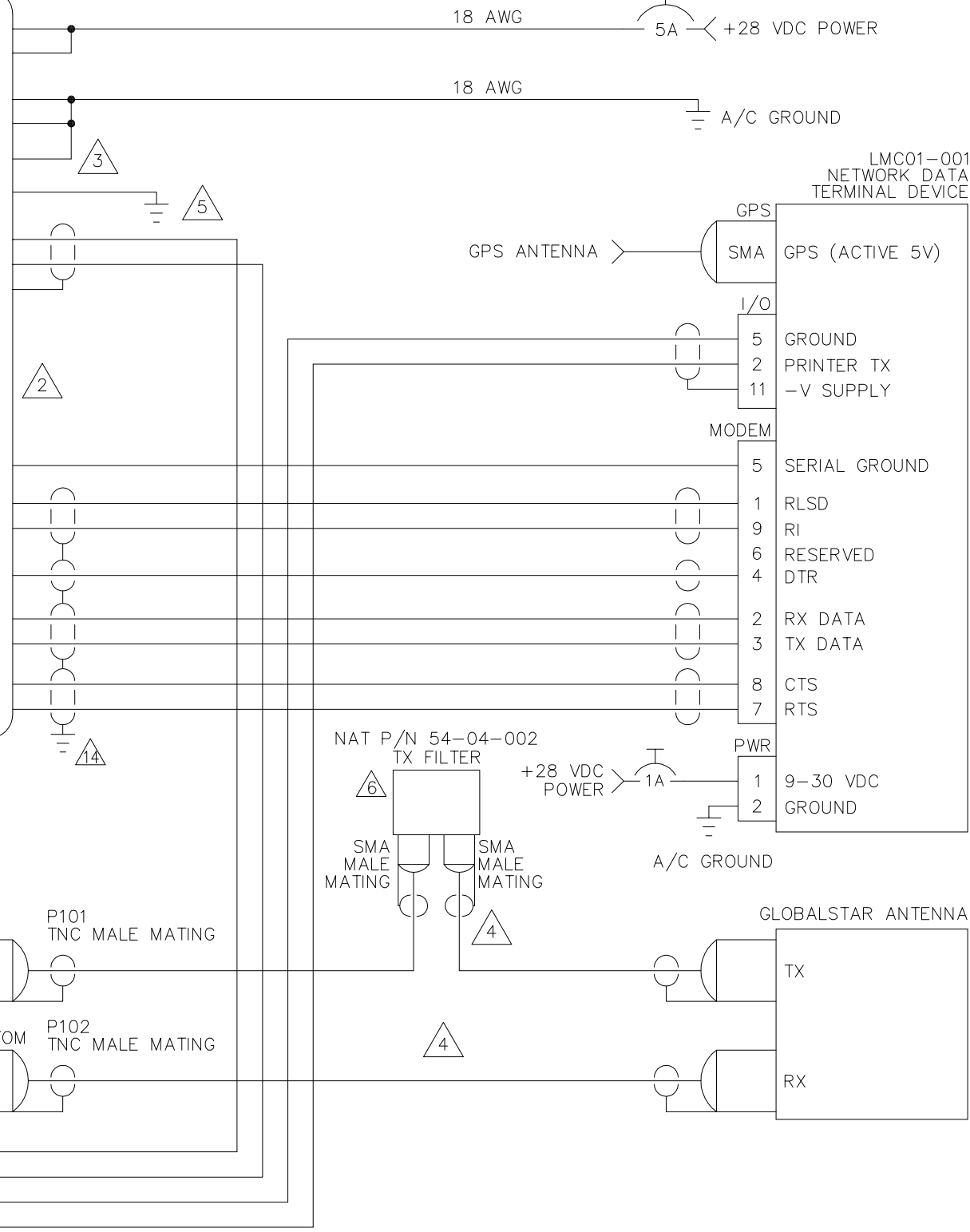

LMC01-001
NETWORK DATA
TERMINAL DEVICE



NOTE: THIS INTERCONNECT IS FOR REFERENCE PURPOSES ONLY.
CONFIRM WIRING ON INDIVIDUAL PRODUCT INTERCONNECT DRAWINGS.

CONFIDENTIAL AND PROPRIETARY TO NAT LTD.

| | | | | | |
|-----------|-----------|--|-----------|--|-------|
| DESIGNED | JH | NAT NORTHERN AIRBORNE TECHNOLOGY LTD. | | | |
| DRAWN | TAT | | | | |
| DATE | APR 20/05 | TITLE | | | |
| CHECKED | | NAT 205 | NAT 255 | STX100 GLOBALSTAR™ SATPHONE SYSTEM WITH PTA12-100 AND LMC01-001 | |
| APPROVED | NAT 114 | SIZE | CAGE CODE | PART NO. | REV. |
| FILE | 403-6.DWG | B | 3AB01 | STX100-000 | 1.00 |
| DWG. TYPE | | INTERCONNECT | | DWG. NO. | SHEET |
| | | | | STX100\000\403-7 | 2/2 |



PTA12-300 POTS Telephone Adapter with NVIS Display SM55-2 Installation and Operation Manual

Section 3 Operation

3.1 Introduction

Information in this section consists of functional and operational procedures for the PTA12-300 POTS Telephone Adapter with NVIS Display.

3.2 General Information

The PTA12-300 POTS Telephone Adapter with NVIS display is a keypad control and display unit for airborne telephone system applications. The PTA12-300 connects to a telephone system transceiver by a two-wire POTS (Plain Old Telephone Service) interface. The PTA12-300 can be connected to the aircraft audio controller(s) or directly to an aviation headset/handset.

Note: The PTA12-300 is designed to meet standard North American PSTN requirements, but it is not recommended or approved for landline applications.

The PTA12-300 POTS Telephone Adapter is a compact Dzus mounted POTS telephone interface with a keypad and display. Many of the PTA12-300 functions are controlled by a microcontroller.

The functions of the PTA12-300 include: speech audio circuits, hook switch, ring indication, flash, hold, redial, serial data communications, backlighting, display, speed dial, Globalstar™ satcom status, DTMF tone generation and ringer audio generate. The speech audio circuits include a mic input amplifier and a phones output amplifier with front panel volume control.

Hook switch control and indication is provided on the front panel. The hook switch may be controlled and its status viewed from a location remote to the PTA12-300 front panel. Ring indication is also provided on the front panel with a flashing green LED. A FLASH button is provided on the front panel to interrupt the hook. A HOLD button on the front panel mutes all audio to and from the headset and is indicated by a green LED. A REDIAL button on the front panel automatically redials the last number called.

The interface to the satcom system transceiver is achieved by a two-wire POTS port. A serial port allows for data communications to satcom systems.

The front panel keypad has NVIS compliant backlighting provided. The display is an LED dot matrix character display with brightness control. The display is filtered for NVIS radiance requirement.

Speed dial allows numbers to be stored and recalled from memory.

Indication of Globalstar™ satcom signal strength and system availability status is provided by LED lit dead-front text on the front panel.



PTA12-300 POTS Telephone Adapter with NVIS Display SM55-2 Installation and Operation Manual

3.3 Controls and Indicators

3.3.1 Display

The PTA12-300 has a 16-character LED NVIS friendly display, with each character block consisting of a 5x7 pixel matrix as shown in Figure 1. Display features depend on the status of the unit and are described in the relevant sections.

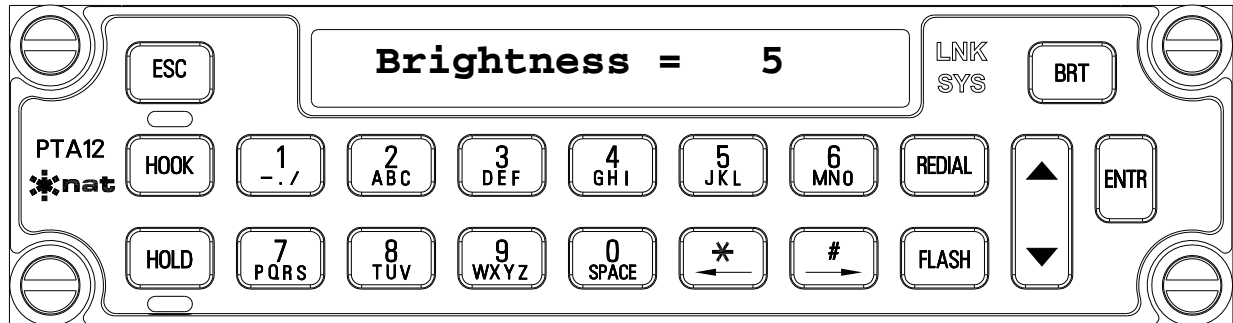

Figure 1: Front View

3.3.1.1 Display Brightness

The front panel BRT button controls display brightness. Each time the BRT button is pressed, the display brightness increases by one step. In Default Power-Up mode only, the display will show the current brightness level (1 through 8) until the next operator action. Once the maximum brightness (8) is reached the brightness level wraps around to the lowest setting (1).

The display is dimmed to half brightness upon activation of the front panel backlighting.

3.3.2 Keypad Controls

The keypad controls are silicone rubber tactile push-buttons backlit by white, green filtered LEDs, and are used to manage all the operator functions of the PTA12.

3.3.2.1 Number and Symbol Buttons

The number (0 through 9) and symbol (*, #) buttons on the keypad have different uses depending on the selected mode. Full information will be given in the relevant sections and in the keypad function table in Section 3.6.

3.3.2.2 HOOK

The HOOK button is pressed to initiate or receive a call. This corresponds to lifting the handset of a telephone 'off the hook'. Each time the HOOK button is pressed, the hook switch toggles on / off.

The 'hook status / ringer active' annunciator is a green LED 'dead-front' text to the left of the screen. The text is not visible when the unit is inactive ('on-hook') and will illuminate continuously when the unit is active ('off-hook'). If the unit is inactive ('on-hook'), this LED also acts as a 'Ringer Active' annunciator by



PTA12-300 POTS Telephone Adapter with NVIS Display SM55-2 Installation and Operation Manual

flashing when an incoming call activates the audible ringing tone on the Ringer Audio output, or in the headset, depending on the installation setting. If the unit is already in use ('off-hook'), the new caller will generally hear a 'busy' signal (depending on the telephone system transceiver used).

Note: The Ringing Detect circuit that activates the headset ringer, the Ringer Audio output and the flashing LED also sends a signal to a further discrete output for a remote indicator (light bulb, etc.) if required.

The hook switch may also be controlled by an external input. The HOOK button on the PTA12-300 front panel has master control of the hook switch control. When the PTA12-300 is configured for remote hook control and PTA12-300 has been selected by an audio panel TX selector, pressing the PTT for at least 0.5 second will activate the hook switch (like pressing and releasing the HOOK button). The hook switch may be released by deselecting the PTA12-300 on the audio panel.

The PTA12-300 may be configured to indicate hook status remotely. In this configuration, an external annunciation device may be used to indicate the status of the PTA12-300 hook switch. This is a discrete output that follows the hook status.

3.3.2.3 HOLD

The HOLD button allows the operator to put a call 'on hold' by muting the microphone and phones audio. This feature is only available when the unit is active ('off-hook').

The hold status annunciator is a green LED below the HOLD button. The LED illuminates to indicate that a call is on hold, and switches off when the call audio is returned to active status.

3.3.2.4 FLASH

The FLASH button is typically used in a system where 'call waiting' and 'call transfer' are supported. When the unit is active ('off-hook'), the FLASH button is used to interrupt a call and allow the user to respond to a second call. This feature is only available when the unit is active ('off-hook') or in Call mode.

3.3.2.5 REDIAL

The REDIAL button recalls and dials the last number dialed (up to 16 digits). This is the number dialed between an off-hook and on-hook cycle. This is non-volatile storage, i.e.: the last dialed number is 'stored' when the unit is powered down.

Pressing REDIAL in Call mode recalls the last number dialed, shows it on the display and dials it immediately.

If the unit is in Default Power-Up mode when the REDIAL button is pressed, the last number dialed is shown on the display. To dial this number, first press the HOOK switch to confirm a dial tone is present and then press the ENTR button to send the DTMF tone on the two-wire interface.

Note: If there are no numbers in the redial buffer, the screen will display Empty! and no number will be dialed.



PTA12-300 POTS Telephone Adapter with NVIS Display SM55-2 Installation and Operation Manual

3.3.2.6 Phones Volume (▲▼)

The UP/DOWN arrow button is a momentary digital rocker switch used to increase and decrease the phones output volume when the PTA12-300 is in Call mode (i.e. the hook switch is active), or when the hook switch is inactive but the Ringer Detect circuit is active.

The phones output volume increases by pressing the ▲ (up) arrow button and decreases with the ▼ (down) arrow button. There are a total of 32 steps from minimum volume to maximum volume and with each ▲ or ▼ press, the display indicates the volume level (1 through 32). The display will show Volume Up or Volume Dn (with the relevant volume level at the right of the display) until the next operator action.

The UP/DOWN arrow button may be used to adjust the phones volume by one step at a time by pressing and releasing the button within one second. The level may also be used to auto-advance by holding down either UP or DOWN for more than one second. In auto-advance mode the volume steps at approximately five levels per second. Once at the top of the volume range (level 32) the control remains at 32 and does not wrap around to level 1. The same is true for the bottom of the range (level 1). Once at level 1 subsequent presses of the DOWN arrow button does not change the level.

The last value of the phones volume is stored in non-volatile memory, and is retained upon power down.

3.3.3 Annunciators

The HOOK and HOLD annunciators are immediately to the left of the display, and the LNK and SYS annunciators are immediately to the right of the display. They are green LED 'dead-front' text annunciators, which means that they are not visible until they are illuminated.

3.3.3.1 HOOK and HOLD Annunciators

The functioning of the HOOK and HOLD annunciators is described in sections 3.3.2.2 and 3.3.3.3.

3.3.3.2 Satcom Annunciators

The other two annunciators, LNK and SYS, are only operational when the PTA12-300 is interfaced to an STX100 satcom data communications port.

3.3.3.3 LNK (Satcom Link)

The LNK text will not be visible (LED off) if the satcom link is down and will illuminate green (LED on) when the satcom link is established.

3.3.3.4 SYS (Satcom System)

The SYS text will not be visible (LED off) if the satcom system is busy and will illuminate green (LED on) when the satcom system is available for voice.



PTA12-300 POTS Telephone Adapter with NVIS Display SM55-2 Installation and Operation Manual

3.4 Name / Number Storage and Display

The PTA12-300 can store up to 16 sets of data, each consisting of two lines: the first line has an identifier (address number) followed by a name and the second line is the associated telephone number.

Each name line starts with the two-digit address number (01 through 16) followed by a colon and has up to 13 character spaces available to store the alphanumeric name. There are up to 16 character spaces for the phone number. The display only shows name or number information at one time. In Recall mode, pressing the ← (#) or → (*) buttons will toggle from name to number or number to name. Full information on storing and editing information is provided in Section 3.5.3.

Note: The # and * buttons may not be used in either the name or number since these buttons are used as ← and → when the PTA12-300 is in edit mode.

3.5 Modes of Operation

Upon initialization, the PTA12-300 is in a Default Power-Up mode and the display will show PTA12-300 X.XX.X, where x.xx.x is the firmware revision number. The unit will automatically enter this mode at power up, or when reset. From Default mode, 3 different modes of operation may be selected: Call mode, Recall mode or Edit mode (see Sections 3.5.1 through 3.5.3).

3.5.1 Call Mode

The PTA12-300 is put in Call mode by pressing the HOOK button. The green HOOK LED will illuminate, the display will show Call Mode (if entered from Default Power-Up mode) and the keypad can then be used just like a telephone to dial numbers.

3.5.1.1 Making a Call in Call Mode

In Call mode (hook switch active) the number (0 through 9) and symbol (*, #) buttons on the keypad are used to 'dial' the required telephone number by generating the corresponding DTMF tone on the POTS output. The digit that has been pressed is shown on the display and the corresponding DTMF tone is sent immediately. The whole number is retained on the display for visual confirmation that the correct number has been dialed. Pressing the HOOK button again terminates the call, turns off the green hook LED, and returns the unit to default mode.

As each button is pressed, audible confirmation is provided on the sidetone of the headset output.

For a summary of button functions available in Call mode refer to Table 2 in Section 3.6.

3.5.1.2 Receiving a call

The hook LED will flash to signal an incoming call. To answer, press the HOOK button (putting the unit into Call mode). The hook LED will then illuminate steady green until the call is terminated by pressing the HOOK button again.



PTA12-300 POTS Telephone Adapter with NVIS Display SM55-2 Installation and Operation Manual

3.5.2 Recall Mode

This mode is entered from Default mode by either keying in a valid number address (01 through 16) as described in Section 3.4, or by pressing the up/down arrow button.

Note: Unlike Edit or Call modes, there is no message on the display to advise that the unit is in Recall mode.

In Recall mode, numbers are retrieved from memory and displayed. The up/down arrow button (▲▼) scrolls through the list of all 16 addresses, whether they are blank or filled. The address name is displayed by default, but if the address name is blank, the corresponding number will be displayed. The ← or → button toggles between name and number.

The up/down arrow button (▲▼) is used to scroll through the list. If the up arrow button (▲) is pressed first, the display scrolls from position 01 upwards until the top of the list is reached. At the top of the list the scroll wraps around to the lowest address. The down arrow button (▼) scrolls downwards from position 16 to the lowest number (01) and then wraps around to the top of the list.

3.5.2.1 Making a Call in Recall Mode

The display will show each stored name or number as it is selected (either by scrolling or direct address selection). When the desired name/number is found and shown on the display, press the HOOK button.

The unit enters Call mode and the hook LED will illuminate green. When a dial tone is heard, press the ENTR button to dial the phone number. In Call mode the HOLD and FLASH functions are available for use. To terminate a call, press the HOOK button again. The unit will exit call mode and the hook LED will go out.

Note: In Recall mode, the ESC button may be used to cancel the current activity and return to Default mode.

3.5.3 Edit Mode

From Default mode, press the ENTR button to select Edit mode. An Edit Mode message is displayed for approximately 2 – 3 seconds and then a message is displayed on how to continue: ↑↓ or Address. It is not necessary to wait for this message before continuing.

If the up/down arrow button (▲▼) is pressed, the complete list of addresses scrolls up or down. This is identical to scrolling operation in Recall mode. In Edit mode, if an address number is keyed, the corresponding address number and name will be displayed without the need for scrolling; for example if the 0 button followed by the 1 button is pressed, the contents of location 01 are displayed.

Each name line starts with a two-digit address number (01 through 16) followed by a colon and has 13 character spaces available to store the alphanumeric name. There are 16 character spaces for the phone number. Any character shown on buttons 0 through 9 may be used to store a name. The relevant button is pressed until the required character is displayed and the ← or → buttons are used to move to the previous or next character if required; for example if the relevant letters are both on the same button. The phone number can consist of up to 16 digits, in numerical form only and each entered number will automatically index on to the next space. The display only shows name or number information at one time. Pressing the ← or → buttons will toggle from name to number or number to name.



PTA12-300 POTS Telephone Adapter with NVIS Display SM55-2 Installation and Operation Manual

3.5.3.1 Keypad Functions in Edit Mode

In Edit mode (hook switch inactive) the keypad buttons do not provide DTMF tones. In Edit mode the lower text portion of these buttons is also implemented. This means that characters 0 through 9, A through Z, -, ., / and space are displayed when the corresponding button is pressed. The desired character for each button is displayed by pressing the key button. Each key press will scroll through the viewable characters for the corresponding button pressed. The → and ← buttons provide horizontal cursor movement in Edit mode. The up/down arrow button (▲▼) provides number scrolling in Recall and Edit modes and provides phone volume adjustment in Call mode. For a summary of the front panel button functions available in Edit and Call mode see Table 2 in Section 3.6.

3.5.3.2 Editing or Entering Address Information

If there is nothing stored in the selected address Empty! will be displayed and pressing the ENTR button will bring up the prompt Enter Name. Using the keypad, characters are entered using the 0 through 9 buttons and edited using the ← and → buttons. When entering name information, alphanumeric characters are available and are selected by pressing the appropriate button. The alpha characters are displayed first and then the numbers. For the button marked 2ABC, the display order will be A, then B, then C, then 2 and will then wrap around to A again. Each time a different button is pressed, the cursor automatically advances by one position. If it is necessary to use the same button for two adjacent characters, the right arrow must be used to advance the cursor. See Table 1 in Section 3.6 for a complete button summary for Edit mode.

After the name has been entered, press the ENTR button to move to the next part of the address and the prompt Enter Number is displayed. Only numbers are available and are entered using the 0 through 9 buttons and edited using ← and → buttons. Each key press (except 0) will automatically advance the cursor by one position even if the same number is entered several times. The 0 (zero) button is also used to enter spaces. Pressing this button displays first 0, then space and then wraps around back to 0 again. When using the 0 button, any combination of adjacent zeroes and/or spaces will necessitate using the arrow button to advance the cursor.

To store the name and number into memory after the number has been entered, the ENTR button must be pressed. The completion message Stored! is then displayed to indicate that the address has been stored, and the unit returns to Edit mode.

To cancel all editing done to the selected address, press the ESC button instead of the ENTR button and the unit will return to Default mode.

If the selected address has stored data, the address name is displayed. If the ENTR button is pressed, the message Del ← or Edit → is displayed. If the current address is to be deleted, press the ← button, and to edit press the → button. If edit is selected, the name is displayed and editing is allowed. The ← button is then used to select the character(s) to be edited. Press the ENTR button to accept and store any changes, or the ESC button to cancel the edit activity. After the name and number have been stored, the message Stored! is displayed to indicate the completion of editing and the unit returns to Edit mode.

Note: If information is stored in the address line but no corresponding phone number is entered (or vice versa), the Empty! message will still be displayed when scrolling through the relevant lines even though there may be information in the other part of the address.

If delete is selected instead of edit, ENTR To Delete is displayed to confirm the delete operation. If the ESC button is pressed, the delete is canceled and the unit returns to Default mode. If the ENTR button is



PTA12-300 POTS Telephone Adapter with NVIS Display SM55-2 Installation and Operation Manual

pressed, the selected address data from both lines is deleted (cleared) and the completion message Deleted! is displayed. The unit then returns to Edit mode.

The ESC button may be used at any time to cancel the current operation. Pressing the ESC button from Edit mode returns the unit to Default power-up mode.

3.6 Keypad Function Tables

The PTA12-300 keypad buttons function differently depending on the current mode of the unit. A brief outline of the differences is given below as a quick reference guide. Table 1 shows Default and Recall modes and Table 2 shows Call and Edit modes.

| Button | Default Power-Up Mode Function | Recall Mode Function |
|--------|--|--|
| 0 – 9 | Number buttons are used only to enter address locations 01 through 16. This puts the PTA12-300 into Recall mode. | Number buttons are used only to enter address locations 01 through 16. |
| * | No function | Only ← available to toggle display between name and number |
| # | No function | Only → available to toggle display between name and number |
| ESC | Cancels current button activity | Default mode is entered |
| HOOK | Call mode is entered (hook switch is toggled to active) | Call mode is entered (hook switch is toggled to active) |
| HOLD | No function | No function |
| REDIAL | Retrieves the last number dialed and displays it. (To send the number, press HOOK and then ENTR) | No function |
| FLASH | No function | No function |
| UP | Puts the PTA12-300 into Recall mode. | Scrolls up through the list of stored numbers |
| DOWN | Puts the PTA12-300 into Recall mode. | Scrolls down through the list of stored numbers |
| BRT | Increases display brightness and wraps around from max to min brightness. Brightness level is displayed. | Increases display brightness and wraps around from max to min brightness |
| ENTR | Puts the PTA12-300 into Edit mode. | No function |

Table 1
Default and Recall Modes



**PTA12-300 POTS Telephone Adapter with NVIS Display
SM55-2 Installation and Operation Manual**

| Button | Call Mode Function | Edit Mode Function |
|---------------|--|---|
| 1 | DTMF tone 1 transmitted and digit 1 displayed | 1, -, ., or / displayed |
| 2 | DTMF tone 2 transmitted and digit 2 displayed | 2, A, B or C displayed |
| 3 | DTMF tone 3 transmitted and digit 3 displayed | 3, D, E or F displayed |
| 4 | DTMF tone 4 transmitted and digit 4 displayed | 4, G, H or I displayed |
| 5 | DTMF tone 5 transmitted and digit 5 displayed | 5, J, K or L displayed |
| 6 | DTMF tone 6 transmitted and digit 6 displayed | 6, M, N or O displayed |
| 7 | DTMF tone 7 transmitted and digit 7 displayed | 7, P, Q, R or S displayed |
| 8 | DTMF tone 8 transmitted and digit 8 displayed | 8, T, U or V displayed |
| 9 | DTMF tone 9 transmitted and digit 9 displayed | 9, W, X, Y or Z displayed |
| 0 | DTMF tone 0 transmitted and digit 0 displayed | 0 or character space displayed |
| * | DTMF tone * transmitted and char * displayed | Only ← available (moves cursor 1 position to left or selects delete data of a selected address) |
| # | DTMF tone # transmitted and char # displayed | Only → available (moves cursor 1 position to right or selects edit data of a selected address) |
| ESC | No function | Cancels current activity during store and returns to Default mode |
| HOOK | Toggles the hook switch to inactive, and enters Default mode | Activates the hook switch and enters Call mode |
| HOLD | Mutes mic and phones | No function |
| REDIAL | Retrieves the last number dialed, displays it, and calls the number | No function |
| FLASH | Takes hook switch inactive for selected flash pulse duration | No function |
| UP | Increases the phones volume | Scrolls up through the list of stored numbers |
| DOWN | Decreases the phones volume | Scrolls down through the list of stored numbers |
| BRT | Increases display brightness and wraps around from max to min brightness | Increases display brightness and wraps around from max to min brightness |
| ENTR | Sends a number dialed from Default or Recall mode | Accepts a data item or completes a sequence. |

Table 2
Call and Edit Modes

Section 3 ends