

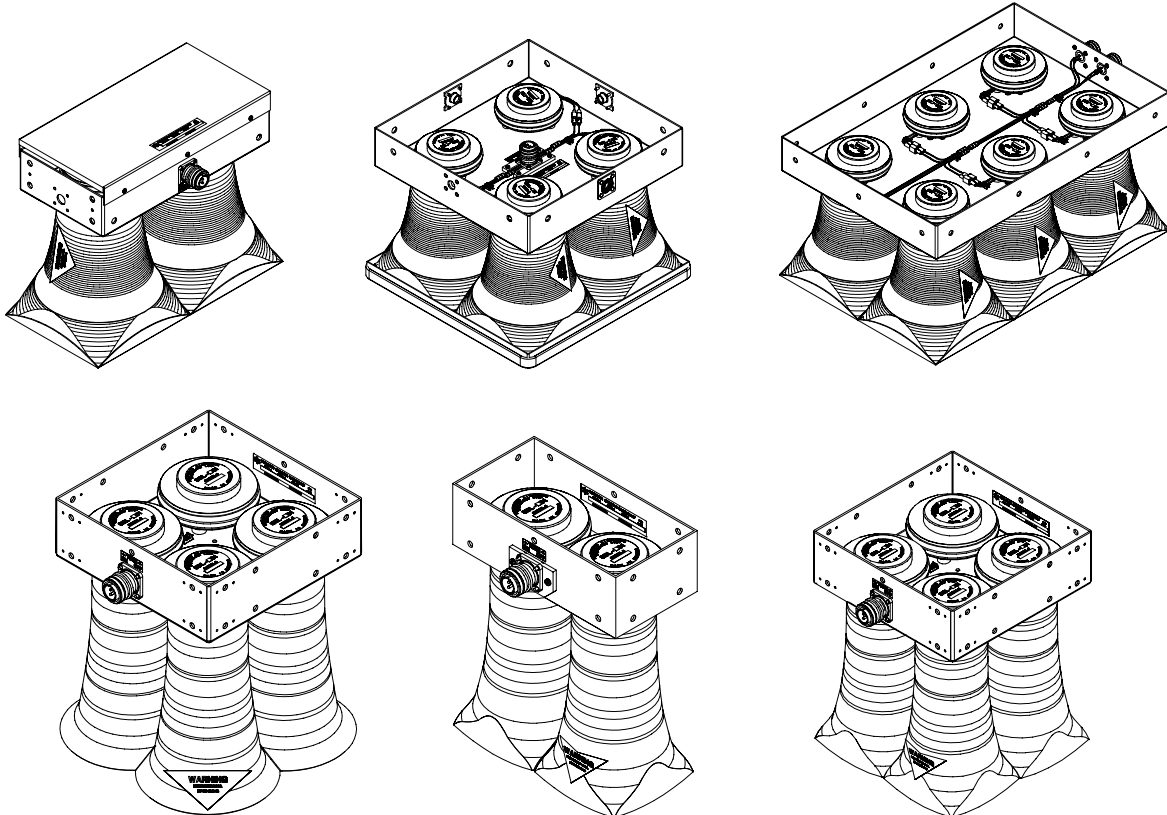

**SM51**

**TS9x Series  
Lightweight Speaker Array**



**INSTALLATION AND OPERATION MANUAL**

**REV 4.00 November 12, 2003**

**Northern Airborne Technology Ltd.  
1925 Kirschner Road  
Kelowna BC, Canada  
V1Y 4N7**

**Telephone (250) 763-2232  
Facsimile (250) 762-3374**

**Copyright 2003 by Northern Airborne Technology**

Periodically NAT will release manual amendments. In order to maintain the most accurate and up to date manual these amendments should be carried out immediately upon receipt and recorded on the following amendment record.

AMENDMENT RECORD				
Amendment Number	Amendment Date	Section(s) Changed	Date Entered	Entered By
1	Mar 10, 2009	2		<b>Performed at factory</b>

Insert any Amendment Instruction sheets after this page.

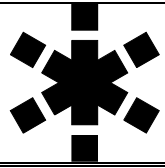

**nat**

**INSTALL\_OPS  
MANUAL AMENDMENT**

**Manual: SM51 (TS9x Series Speaker Array)    Amendment #: 1**  
**Document # SM51\Install\_Ops\809-0001    Amendment Date: Mar 10, 2009**

The purpose of this amendment is to add the latest drawing revision to the manual.

Amendment Instructions:

1	Remove Pages	Replace With Pages
	2-1 and 2-2 Rev 4.00	2-1 and 2-2 Rev 4.00 Amendment 1

2	Remove Drawings (Section 2)	Replace or add Drawings (Section 2)
	AA21-400\403-0 Rev 1.00	AA21-400\403-0 Rev 1.01

**Note:** Ensure that all drawings are inserted in the order shown on the latest drawing lists.

- 3    Update the Amendment Record sheet at the front of the manual.
- 4    Insert this page into the manual after the Amendment Record sheet (page ii).

Manual Amendment ends after the following amended pages

**Table of Contents**

<b>Section</b>	<b>Title</b>	<b>Page</b>
1.0	Description	
1.1	Introduction	1-1
1.2	Purpose of Equipment	1-1
1.3	Features	1-1
1.4	Specifications	1-1
1.4.1	Performance Specifications	1-1
1.4.2	Physical Specifications	1-2
1.5	System Configuration	1-2
2.0	Installation	
2.1	Introduction	2-1
2.2	Unpacking and Inspection	2-1
2.3	Installation Procedures	2-1
2.3.1	Warnings	2-1
2.3.2	Cautions	2-1
2.3.3	Cabling and Wiring	2-1
2.3.4	Mechanical Installation	2-2
2.3.5	Post-Installation Checks	2-2
2.4	Continued Airworthiness	2-2
2.5	Installation Drawings	2-2
3.0	Operation	
3.1	Operation Specifics	3-1

## Section 1.0 Description

### 1.1 Introduction

This manual contains information on the TS9x Lightweight Speaker arrays.

Information in this section consists of purpose of equipment, features and specifications.

### 1.2 Purpose of Equipment

The TS9x speaker arrays are lightweight, high output power loudspeakers for use in air-to-ground, air-to-sea, or ground-to-ground audible communication systems. The TS9x speaker array series are used with the PA250 and PA700 series amplifiers.

### 1.3 Features

This series of speakers is available in multiples of two bells, which allows the user to vary the range and/or dispersal pattern depending on the mounting configurations. TS92's are used for large area dispersion, and TS93/TS94's are for more focused applications. The driver assembly and mechanical parts are field replaceable for ease of maintenance.

### 1.4 Specifications

#### 1.4.1 Performance Specifications

Loudhailer	Total Bell Configuration	Amplifier	Input Power	Output Level @ 1m
<b>TS92-02</b>	2	PA250	28 Vdc	130 dB
<b>TS94-02</b>	2	PA250	28 Vdc	128 dB
<b>TS92-04</b>	4	PA250	28 Vdc	136 dB
<b>2 x TS92-02</b>	4	PA250	28 Vdc	136 dB
<b>TS92-04</b>	4	PA250	33 Vdc	137 dB
<b>2 x TS92-02</b>	4	PA250	33 Vdc	137 dB
<b>TS93-04</b>	4	PA250	28 Vdc	134 dB
<b>TS94-04</b>	4	PA250	28 Vdc	134 dB
<b>TS93-04</b>	4	PA250	33 Vdc	135 dB
<b>TS94-04</b>	4	PA250	33 Vdc	135 dB
<b>2 x TS92-04</b>	8	PA700	28 Vdc	140 dB
<b>2 x TS92-04</b>	8	PA700	33 Vdc	141 dB

At the time of publication, performance information was available only for the speakers listed above. For details of other units, please contact the Product Support department at NAT.

## 1.4.2 Physical Specifications

---

See **Mechanical Installation** drawings (TS9x-xxxx\922-0) for speaker array physical specifications (where x is the model reference of the specific unit under consideration, i.e. TS92-04XN\922-0.)

## 1.5 System Configuration

---

---

The TS9x Speaker Array should be chosen to match the audio output power of the PA System amplifier. As a general rule, the system should have one speaker driver (minimum) for each 100 watts of audio power.

For example: a 400 watt system requires 4 speaker drivers = TS9x-04xx

Failure to follow this rule can result in the speakers being overdriven, leading to high levels of distortion and premature failure of the speaker drivers.

End of section 1.0

## Section 2.0 Installation

### 2.1 Introduction

---

Information in this section consists of: unpacking and inspection procedures, installation procedures, post-installation checks, and installation drawings.

### 2.2 Unpacking and Inspection

---

Unpack the equipment carefully and locate the warranty card. Inspect the unit visually for damage due to shipping and report all such claims immediately to the carrier involved. Note that each unit should have the following:

- TS9x Lightweight Speaker Array
- Warranty Card
- Release certification

Verify that all items are present before proceeding and report any shortage immediately to your supplier.

Complete the warranty card information and send it to NAT when the installation is complete. If you fail to complete the warranty card, the warranty will be activated on date of shipment from NAT.

### 2.3 Installation Procedures

---

#### 2.3.1 Warnings

---

Stand clear, this equipment operates at an intense sound level. Personnel must be kept away from the direct loudspeaker beam.

#### 2.3.2 Cautions

---

Do not operate the equipment in a hangar or in confined areas.

Do not operate the equipment with snow, water or other foreign matter in the loudspeaker horn.

Do not clean the loudspeaker with compressed air.

#### 2.3.3 Cabling and Wiring

---

All unshielded wire should be MIL-W-22759 or equivalent. For shielded wire applications, use Tefzel MIL-M-27500 or MIL-M-81044 shielded wire with solder sleeves

(for shield terminations) to make the most compact and easily terminated interconnect. Follow the wiring diagrams in Section 2.5 as required.

### 2.3.4 Mechanical Installation

The installing agency is responsible for the design, engineering and installation of the mounting bracket for the TS9x Speaker Array. Careful consideration should be given to the operating environment and the mechanical forces acting upon the TS9x unit(s).

### 2.3.5 Post-Installation Checks

Ensure all connectors are tight and the speaker array mechanical installation is sound.

When the PA system installation is complete, carry out a full performance test to ensure that all components of the system (including the loudspeaker array) are functioning correctly. For full post-installation check information, refer to the relevant PA System and Power Amplifier service manuals.

## 2.4 Continued Airworthiness

Maintenance of the TS9x is 'on condition' only. Periodic maintenance of this product is not required.

## 2.5 Installation Drawings

DRAWING	REV.	DESCRIPTION	TYPE
AA21\400\403-0	1.01	Cabin PA System	Interconnect
AA22\492\403-1	1.00	PA/Siren System 250 Watt	Interconnect
AA22\492\403-2	1.01	PA/Siren System 700 Watt	Interconnect
PA250\407-0	1.00	PA250 Amplifier	Cabling Diagram
PA700\001\407-0	1.00	700 Watt System	Cable Diagram
PA700\001\407-1	1.00	1400 Watt System	Cable Diagram
PA700\001\407-2	1.00	2100 Watt System	Cable Diagram
TS92\02XM\922-0	1.01	Speaker Array 2 Bell Standard W/Clutch Mount	Mechanical Installation
TS92\02XN\922-0	1.01	Speaker Array 2 Bell Standard	Mechanical Installation
TS92\04XN\922-0	1.01	Speaker Array 4 Bell Standard	Mechanical Installation
TS92\06XN\922-0	1.01	Speaker Array 6 Bell Standard	Mechanical Installation
TS93\04XN\922-0	1.00	Speaker Array 4 Bell Cloverleaf	Mechanical Installation
TS94\02XN\922-0	1.00	Speaker Array 2 Bell Mini	Mechanical Installation
TS94\04XN\922-0	1.00	Speaker Array 4 Bell Mini	Mechanical Installation

Section 2.0 ends after these Drawings

REVISIONS			
REV	DESCRIPTION	DATE	BY
1.01	DOCCRO2739 - ADDED NOTE 8.	FEB 5/09	TAT

AA21-400  
CABIN PA SYSTEM J101

P101  
25 PIN FEMALE D-MIN  
MATING CONNECTOR

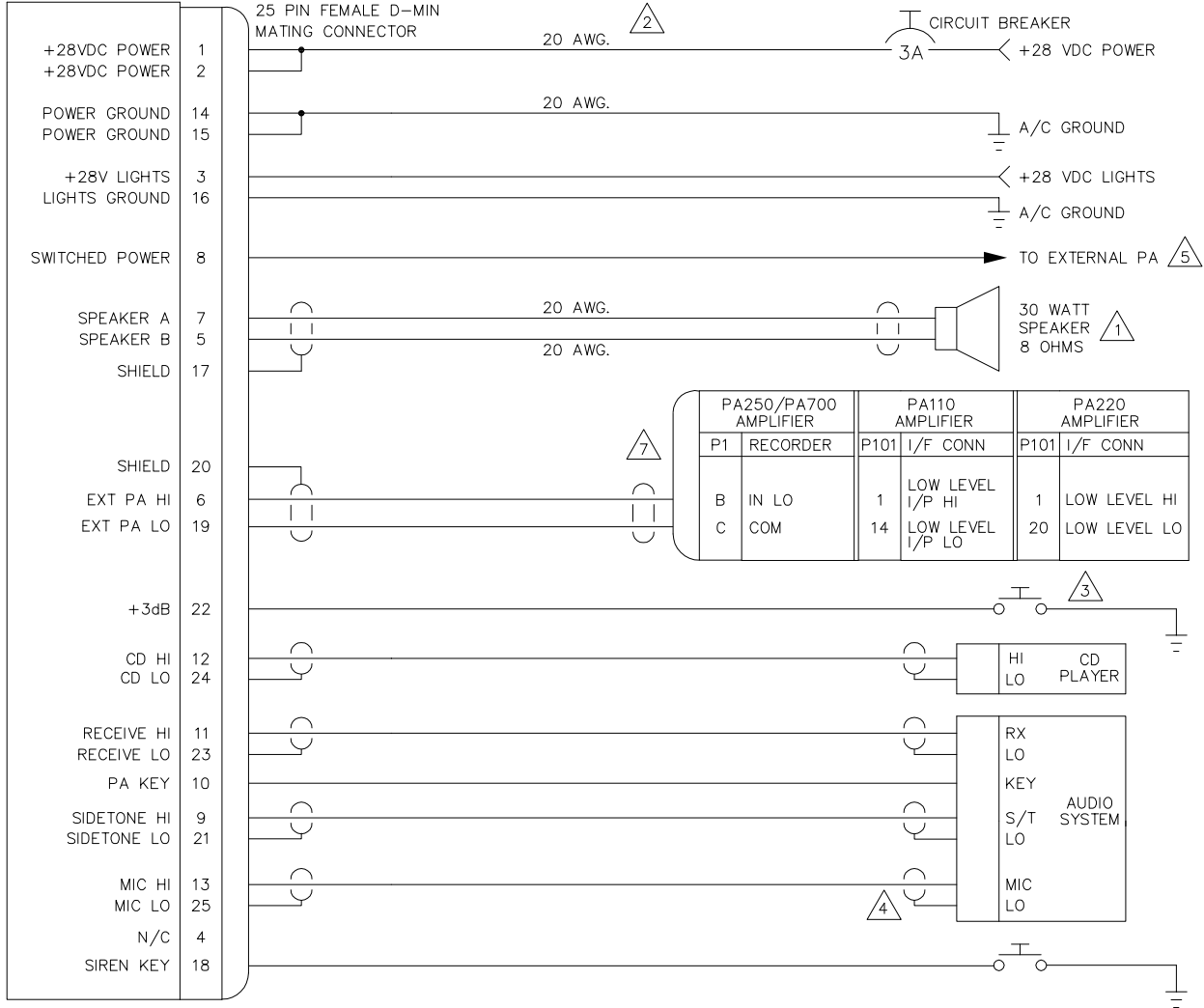

NOTES:

- 1 EQUIVALENT SERIES/PARALLEL SPEAKERS MAY BE USED.
- 2 ALL WIRES SHOULD BE 22 AWG UNLESS OTHERWISE SPECIFIED. ALL UNSHIELDED WIRE SHALL BE SELECTED IN ACCORDANCE WITH AC43.13-1B CHANGE 1, PARAGRAPHS 11-76 THROUGH 11-78. WIRE TYPES SHOULD BE TO MIL-W-22759 AS SPECIFIED IN AC43.13-1B CHANGE 1, PARAGRAPHS 11-85, 11-86 AND LISTED IN TABLE 11-11. ALL SHIELDED WIRE/CABLE SHOULD BE IN ACCORDANCE WITH MIL-C-27500.
- 3 GROUND TO REDUCE OUTPUT BY 3dB.
- 4 MIC LO MUST BE GROUNDED AT AUDIO PANEL.
- 5 +28VDC @ 400mA MAX.
- 6 JUMPER CONFIGURED. ONLY RECEIVE OR CD MAY BE USED AT ONE TIME.
- 7 REFER TO AA21 INSTALLATION AND OPERATION MANUAL FOR CORRESPONDING AA21 JUMPER SETTING.
- 8 WHEN CONNECTED TO AN AUDIO SYSTEM WITHOUT A PA KEY OUTPUT, CONNECT PIN 10 TO GROUND. WHEN CONNECTED TO AN AUDIO SYSTEM WITH A PA KEY OUTPUT, CONNECT AS SHOWN

DEFINITIONS:

N/C:  
NO CONNECTION. THE PIN IS NOT CONNECTED TO ANYTHING INTERNALLY, AND THEREFORE SHALL HAVE NO CONNECTION EXTERNALLY.

RESERVED:  
MAY BE CONNECTED AND USED IN THE FUTURE. THE CIRCUITRY MAY BE PRESENT OR ADDED TO ACTIVATE THE FUNCTION. THE PIN MAY BE USED FOR TEST PURPOSES. THERE IS NO EXTERNAL CONNECTION.

PROPRIETARY AND CONFIDENTIAL TO NAT LTD.

DESIGNED	RL	 <b>NAT</b> NORTHERN AIRBORNE TECHNOLOGY LTD.				
DRAWN	SRK					
DATE	NOV 9/99	TITLE				
CHECKED	NAT 255	CABIN PA SYSTEM				
APPROVED	NAT 131	SIZE	CAGE CODE	PART NO.	REV.	SHEET
FILE	403-0.DWG	A	3AB01	AA21-400	1.01	1/1
DWG. TYPE		INTERCONNECT		DWG. NO. AA21\400\403-0		

AA22-492

J101  
P101  
25 PIN FEMALE DMIN  
MATING CONNECTOR

1	+28 VDC POWER
2	+28 VDC POWER
3	+28 VDC LIGHTS
14	POWER GROUND
15	POWER GROUND
16	POWER GROUND
8	SWITCH POWER OUT
4	RESERVED
5	RESERVED
9	RESERVED
7	AUDIO OUT HI
6	AUDIO OUT HI
19	AUDIO OUT LO
11	RADIO INPUT HI
23	RADIO INPUT LO
12	PA INPUT HI
24	PA INPUT LO
13	MIC INPUT HI
25	MIC INPUT LO
10	SIREN KEY IN
17	SHIELD GROUND
18	GROUND
20	GROUND
21	GROUND
22	GROUND

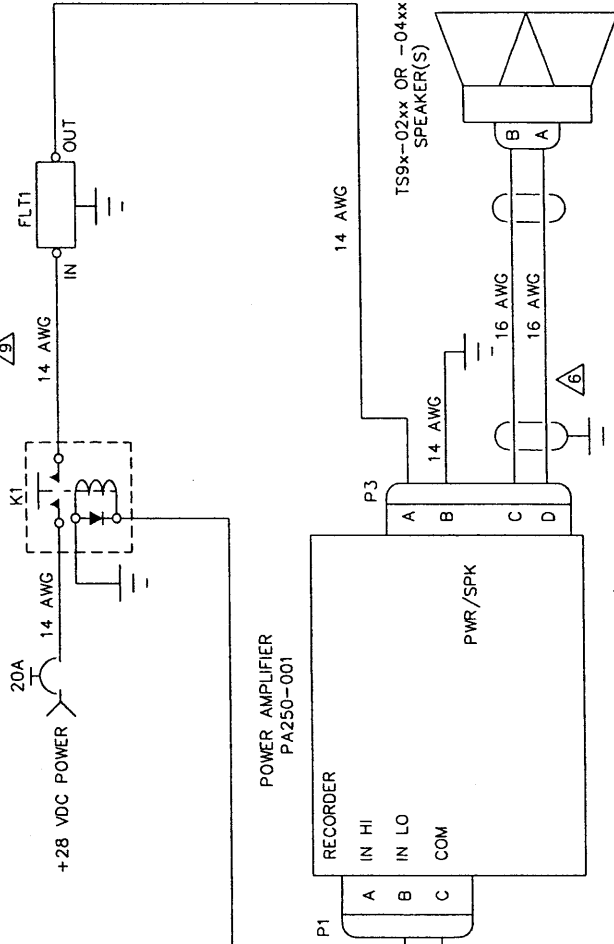
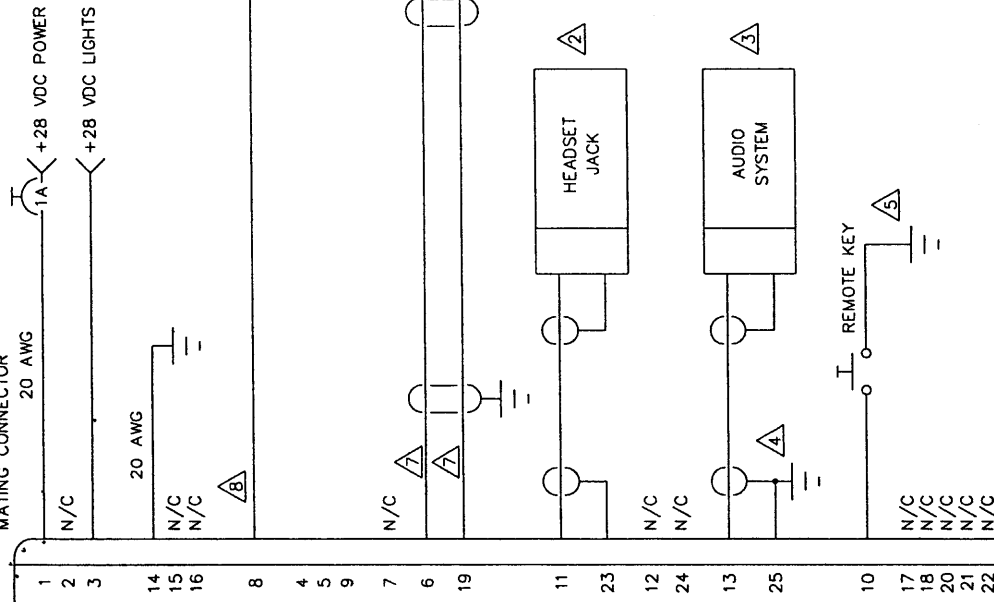

NOTES:

- 1 ALL WIRES SHOULD BE 22 AWG UNLESS OTHERWISE SPECIFIED. ALL WIRE SHOULD BE IN ACCORDANCE WITH MIL-W-22759. ALL SHIELDED WIRE/CABLE SHOULD BE IN ACCORDANCE WITH MIL-C-27500.
- 2 OPTIONAL PARALLEL TO HEADPHONE (1 ONLY) CONNECTION FOR MONITORING RADIOS VIA EXTERNAL P.A. SPEAKER.
- 3 OR CARBON-EQUIVALENT/AMPLIFIED DYNAMIC MICROPHONE.
- 4 MIC INPUT LO (PIN 25) MUST GO TO EXTERNAL GROUND TO EXCITE MICROPHONE, IF NOT PROVIDED BY AUDIO SYSTEM.
- 5 FOR CYCLIC-SWITCH KEYING, WIRE AS SHOWN. FOR FRONT-PANEL AUTO-KEYING, GROUND PIN 10.
- 6 SHIELD TO REDUCE INTERFERENCE WITH OTHER SYSTEMS.
- 7 ISOLATED TRANSFORMER OUTPUT. 'AUDIO OUT LO' MUST BE TERMINATED AT P1 'C'.
- 8 SWITCH POWER OUT (PIN 8) RATED 400mA @ 28VDC.
- 9 K1 RELAY NAT P/N 65-80-200 OR EQUIVALENT. FLT1 RF FILTER NAT P/N 22-00-003A OR EQUIVALENT.

PROPRIETARY AND CONFIDENTIAL TO NAT LTD.

DESIGNED	RL			
DRAWN	TAT			
DATE	SEP 25/00	TITLE		
CHECKED	NAT 114	PA/SIREN SYSTEM 250 WATT		
APPROVED	NAT 107	SIZE	CAGE CODE	REV.
		A	3AB01	1.00
FILE	403-1100.DWG	DWG. TYPE	INTERCONNECT	DWG. NO.
				AA22\492\403-1
				SHEET
				1/1

**nat** NORTHERN AIRBORNE TECHNOLOGY LTD.

REV	DESCRIPTION	DATE	BY
1.01	ECR #1481 - CHANGED NOTES 1, 3 & 7; ADDED NOTES 8 & 9; FORMAT CHANGES.	SEP 26/00	TAT

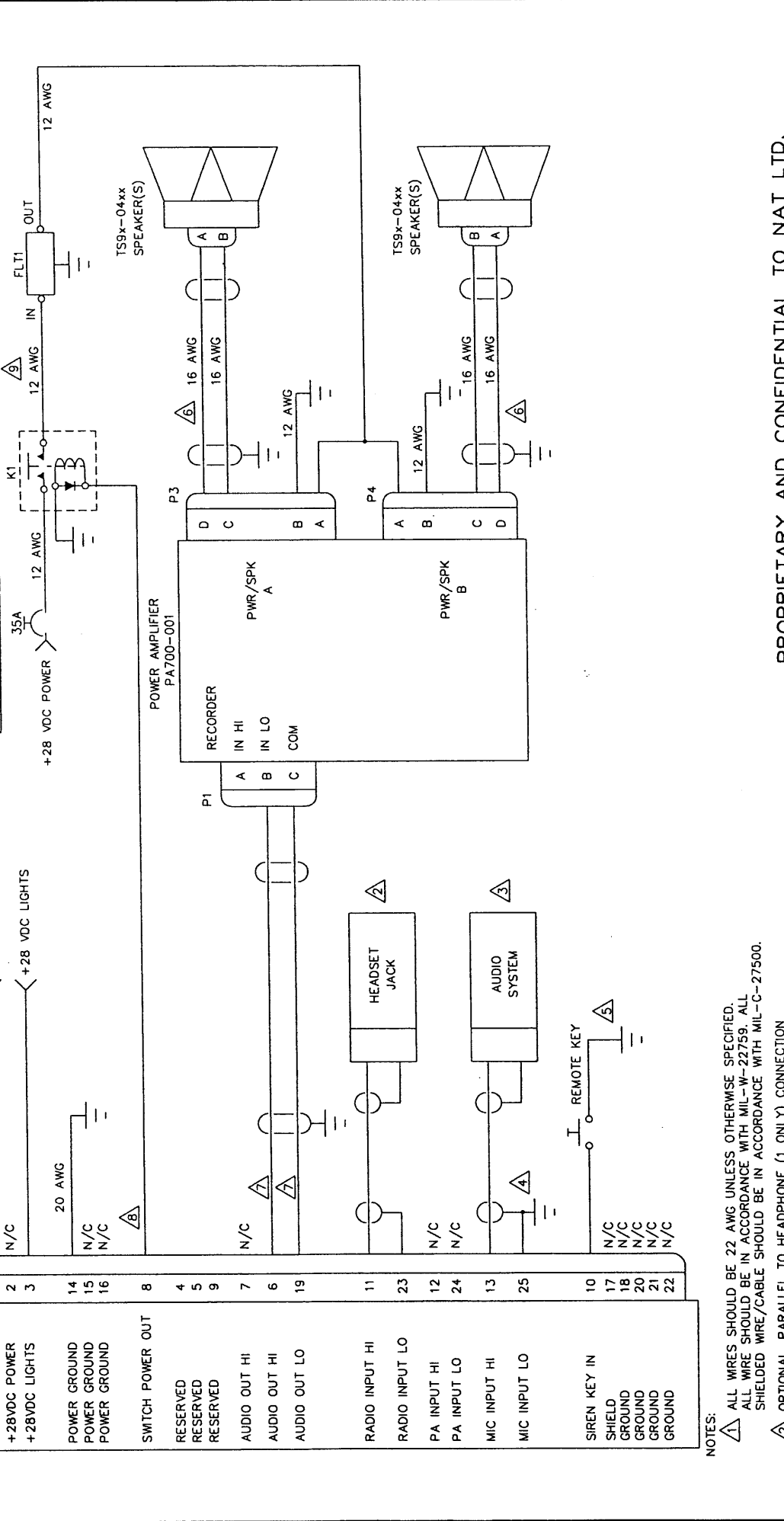

DESIGNED	RL	TGM	TITLE
DRAWN			PA/SIREN SYSTEM 700 WATT
DATE	JAN 12/98		
CHECKED	NAT 114	NAT 113	
APPROVED	NAT 107		
FILE	403-2101.DWG	DWG. TYPE	INTERCONNECT
	SIZE	CAGE CODE	PART NO.
	A	3AB01	AA22-492
	REV.		SHEET
	1.01		1/1
	DWG. NO.	AA22\492\403-2	

PROPRIETARY AND CONFIDENTIAL TO NAT LTD.

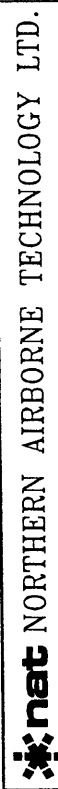



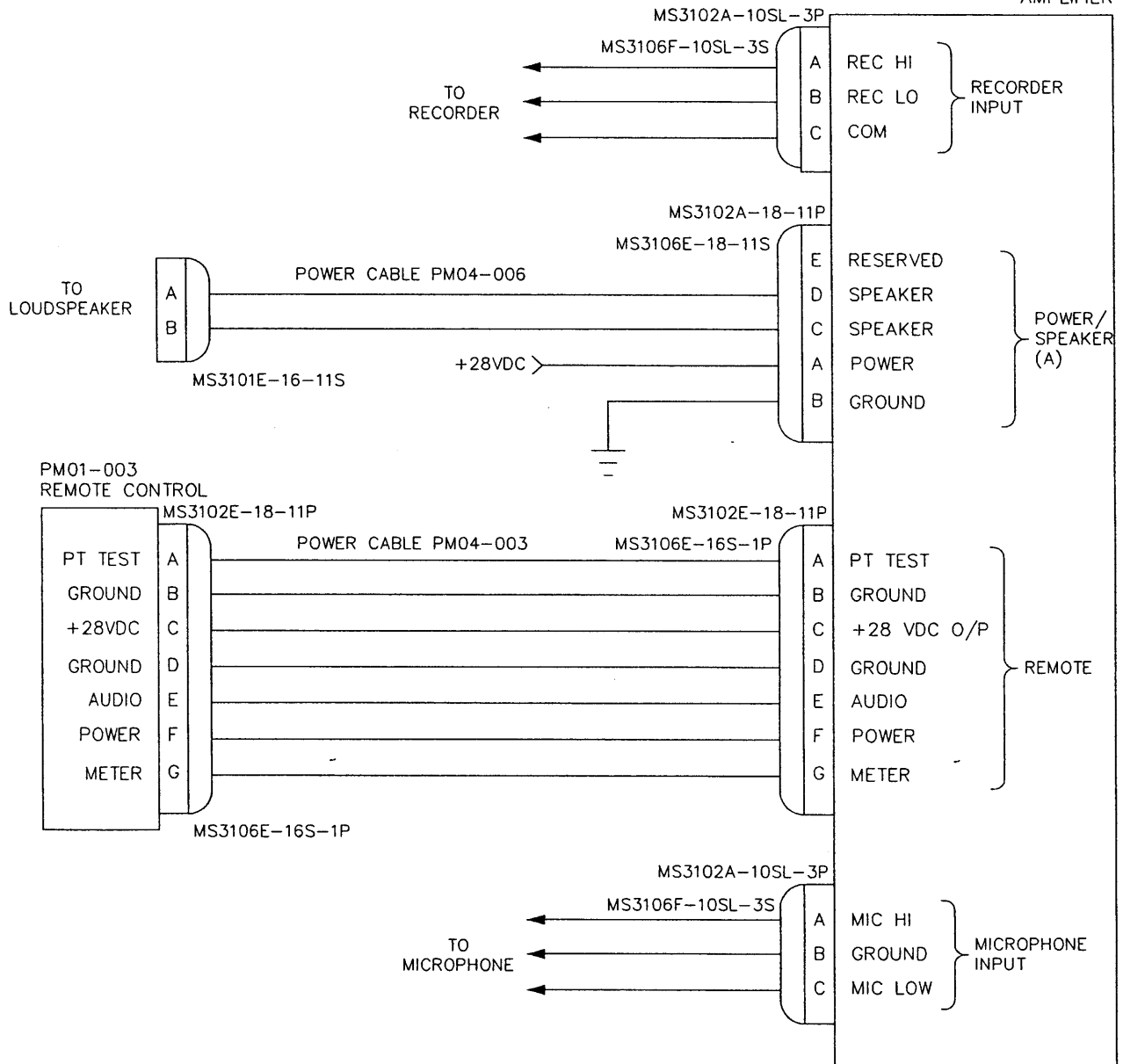

- NOTES:
- ALL WIRES SHOULD BE 22 AWG UNLESS OTHERWISE SPECIFIED. ALL WIRE SHOULD BE IN ACCORDANCE WITH MIL-W-22759. ALL SHIELDED WIRE/CABLE SHOULD BE IN ACCORDANCE WITH MIL-C-27500.
  - OPTIONAL. PARALLEL TO HEADPHONE (1 ONLY) CONNECTION FOR MONITORING RADIOS VIA EXTERNAL P.A. SPEAKER.
  - OR CARBON-EQUIVALENT/AMPLIFIED DYNAMIC MICROPHONE.
  - MIC INPUT LO (PIN 25) MUST GO TO EXTERNAL GROUND TO EXCITE MICROPHONE, IF NOT PROVIDED BY AUDIO SYSTEM.
  - FOR CYCLIC-SWITCH KEYING, WIRE AS SHOWN. FOR FRONT-PANEL AUTO-KEYING, GROUND PIN 10.
  - SHIELD TO REDUCE INTERFERENCE WITH OTHER SYSTEMS.
  - ISOLATED TRANSFORMER OUTPUT. 'AUDIO OUT LO' MUST BE TERMINATED AT PIN 'C'.
  - SWITCH POWER OUT (PIN 8) RATED 400mA @ 28VDC.
  - RELAY NAT P/N 65-80-200 OR EQUIVALENT.
  - RF FILTER NAT P/N 22-00-003A OR EQUIVALENT.

PA250-001  
AMPLIFIER



PROPRIETARY AND CONFIDENTIAL TO NAT LTD.

DESIGNED	-	 <b>nat</b> NORTHERN AIRBORNE TECHNOLOGY LTD.				
DRAWN	MWS					
DATE	OCT 12/00	TITLE PA250 AMPLIFIER				
CHECKED	 					
APPROVED		SIZE A	CAGE CODE 3AB01	PART NO. PA250	REV. 1.00	SHEET 1/1
FILE	407-0100.DWG	DWG. TYPE	CABLING DIAGRAM	DWG. NO.	PA250\407-0	

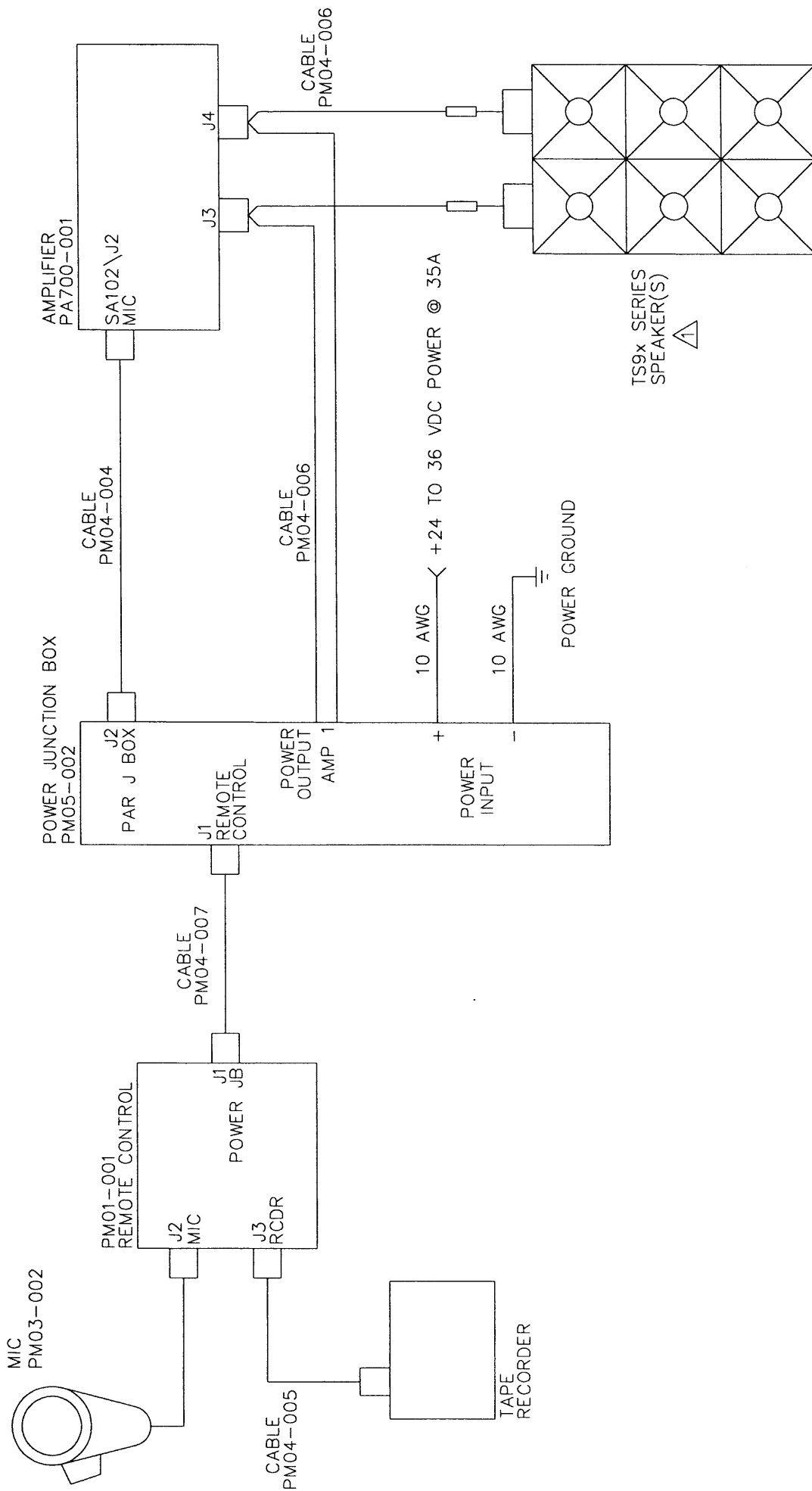

PROPRIETARY AND CONFIDENTIAL TO NAT LTD.

DESIGNED	JD				
DRAWN	TAT				
DATE	AUG 30/00	TITLE		700 WATT SYSTEM	
CHECKED	NAT 114	SIZE	A	CAGE CODE	3AB01
APPROVED	NAT 107	PART NO.	PA700-001	REV.	1.00
FILE	407-0100.DWG	DWG. TYPE	CABLE DIAGRAM	DWG. NO.	PA700\001\407-0
				SHEET	1/1

NOTES:  
 ⚠ CONSULT FACTORY FOR SPEAKER CONFIGURATION OPTIONS.



**nat** NORTHERN AIRBORNE TECHNOLOGY LTD.

MIC  
PM03-002

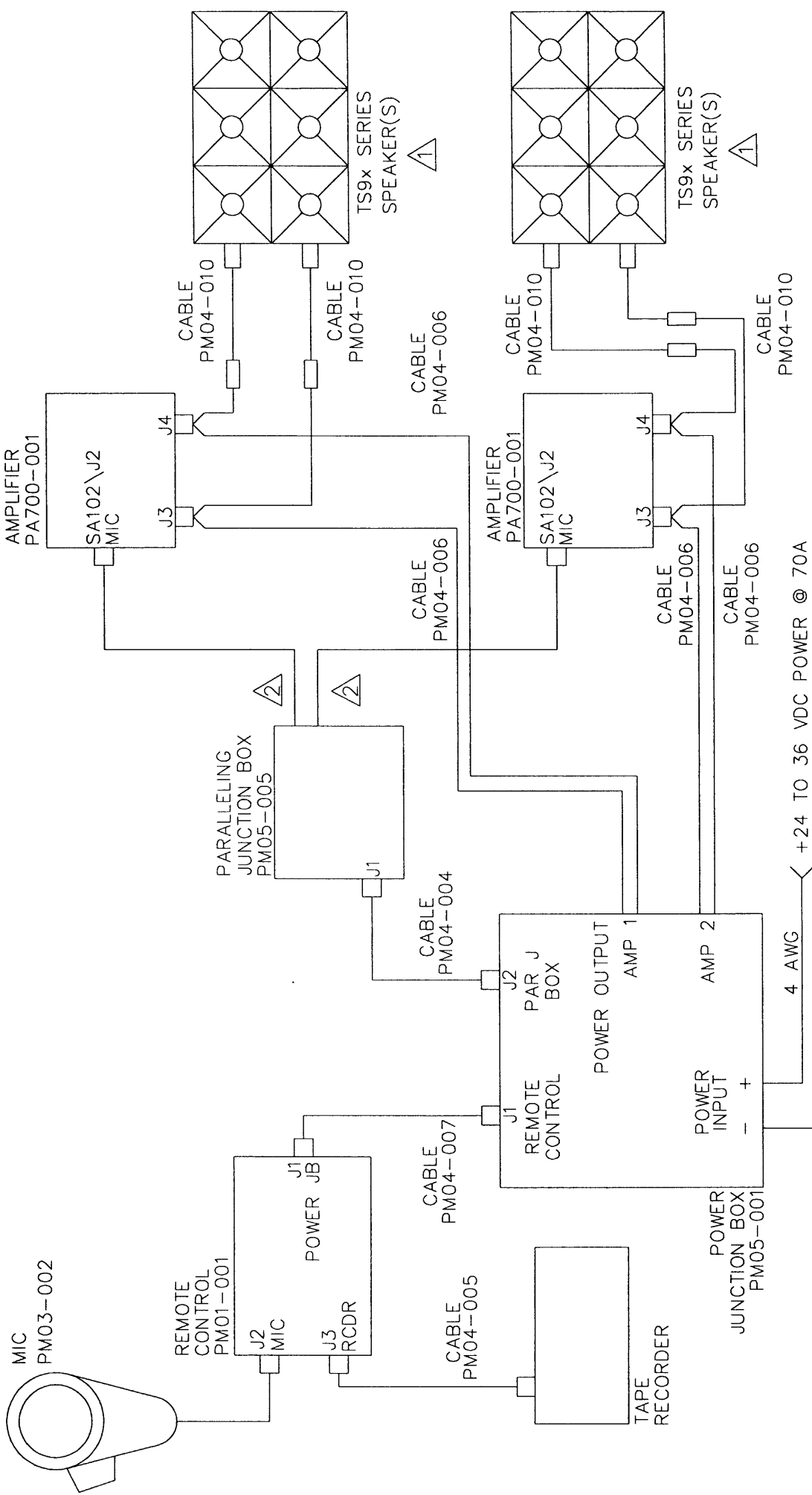

PROPRIETARY AND CONFIDENTIAL TO NAT LTD.

DESIGNED	JD	TITLE		
DRAWN	TAT	1400 WATT SYSTEM		
DATE	AUG 30/00	SIZE	CAGE CODE	PART NO.
CHECKED	NAT 114	A	3AB01	PA700-001
APPROVED	NAT 107	DWG. TYPE	CABLE DIAGRAM	DWG. NO. PA700\001\407-1
FILE	407-1100.DWG	REV.	1.00	SHEET 1/1



CONSULT FACTORY FOR SPEAKER CONFIGURATION OPTIONS.  
PENDANT CABLE ASSEMBLY, PART OF PM05-005.

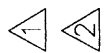

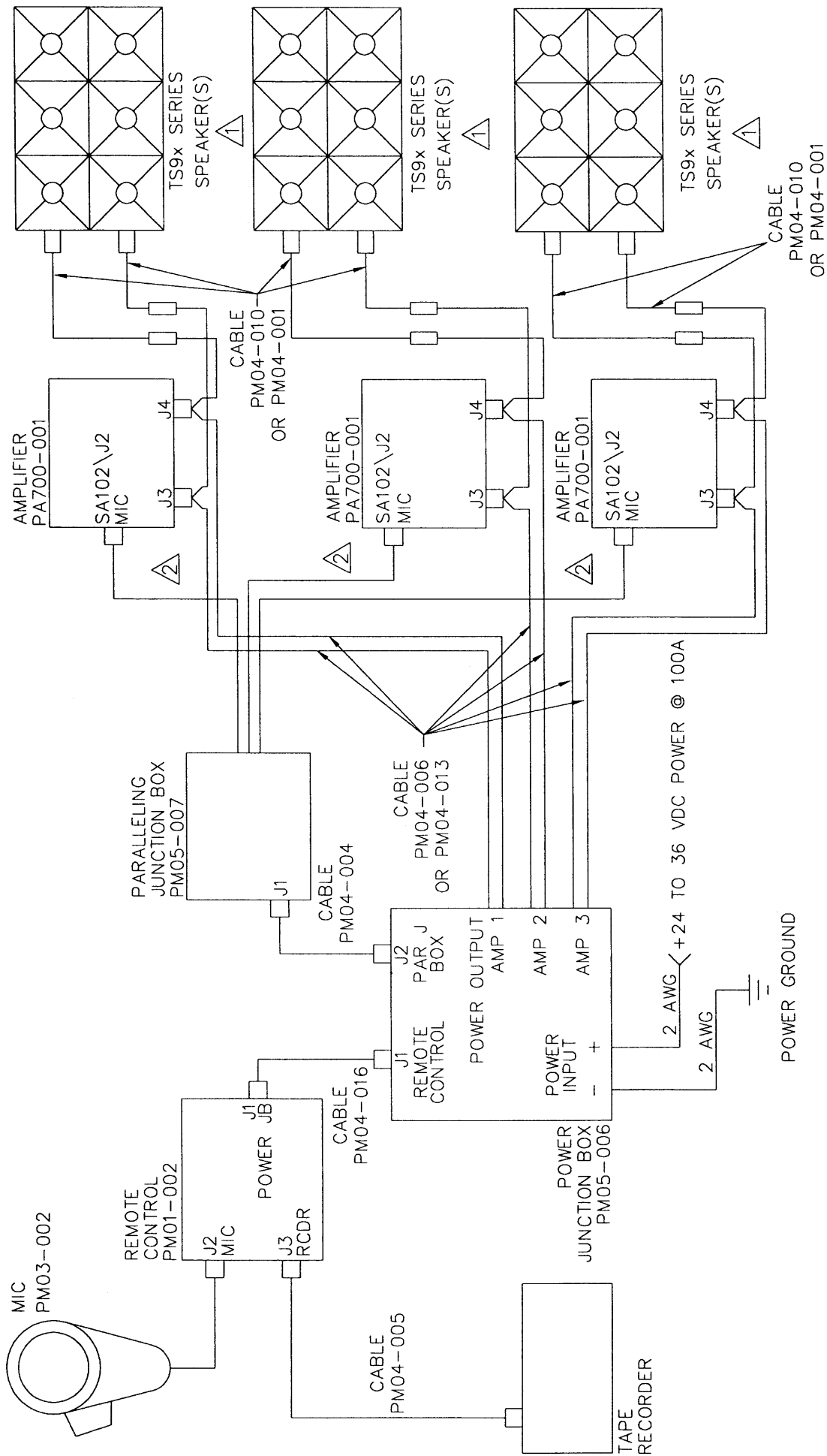

PROPRIETARY AND CONFIDENTIAL TO NAT LTD.

DESIGNED	JD	TITLE		SIZE	CAGE CODE	PART NO.	REV.	SHEET
DRAWN	TAT	AUG 30/00		A	3AB01	PA700-001	1.00	1/1
DATE		NAT 223		APPROVED	CABLE DIAGRAM		DWG. NO. PA700\001\407-2	
CHECKED	NAT 114	NAT 107		DWG. TYPE		DWG. NO. PA700\001\407-2		

**nat** NORTHERN AIRBORNE TECHNOLOGY LTD.

2100 WATT SYSTEM

FILE

407-2100.DWG

CONSULT FACTORY FOR SPEAKER CONFIGURATION OPTIONS.

PENDANT CABLE ASSEMBLY, PART OF PM05-007.



REVISIONS			
REV	DESCRIPTION	DATE	BY
1.01	ECR #1406 - ADDED MOUNTING HOLE DIMENSIONS, HOLE SCHEDULE AND NEW VIEW, FORMAT CHANGES.	JUN 1/99	TAT

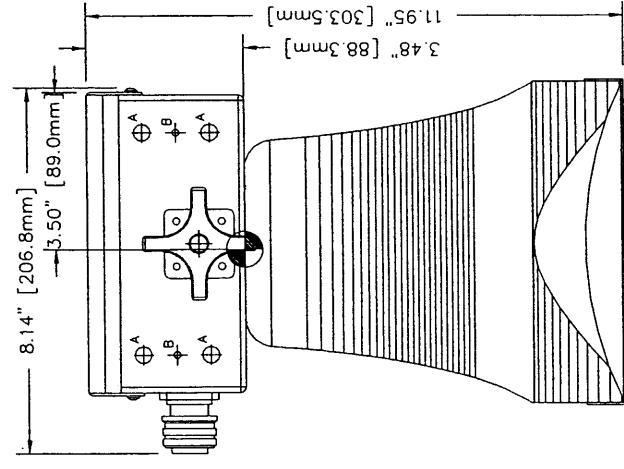
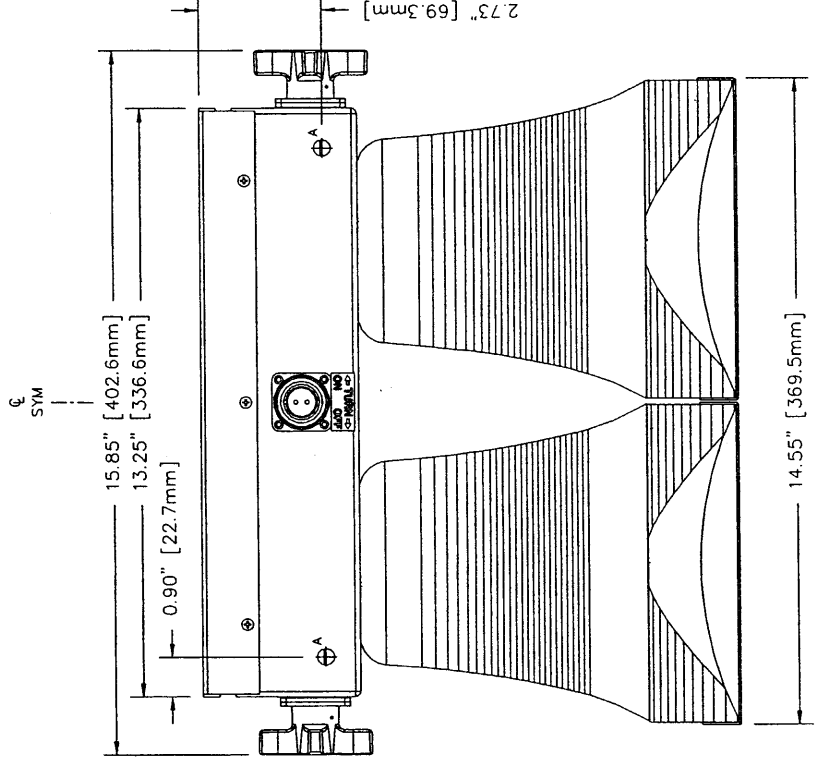
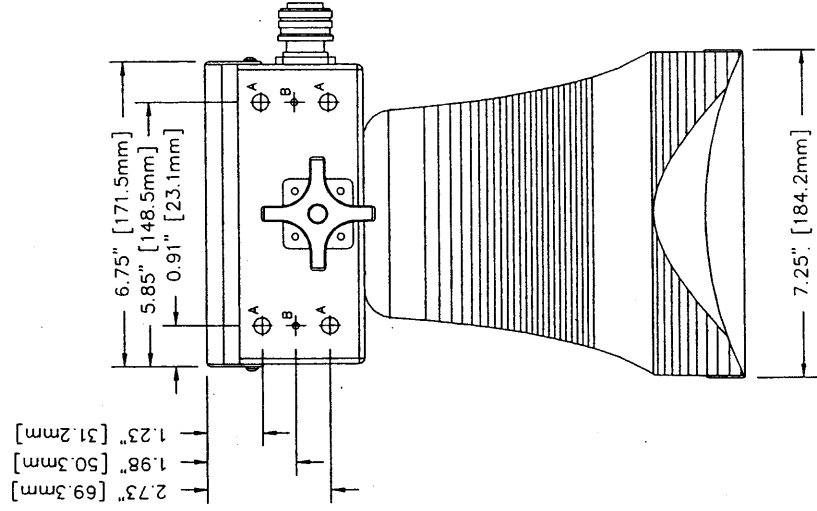
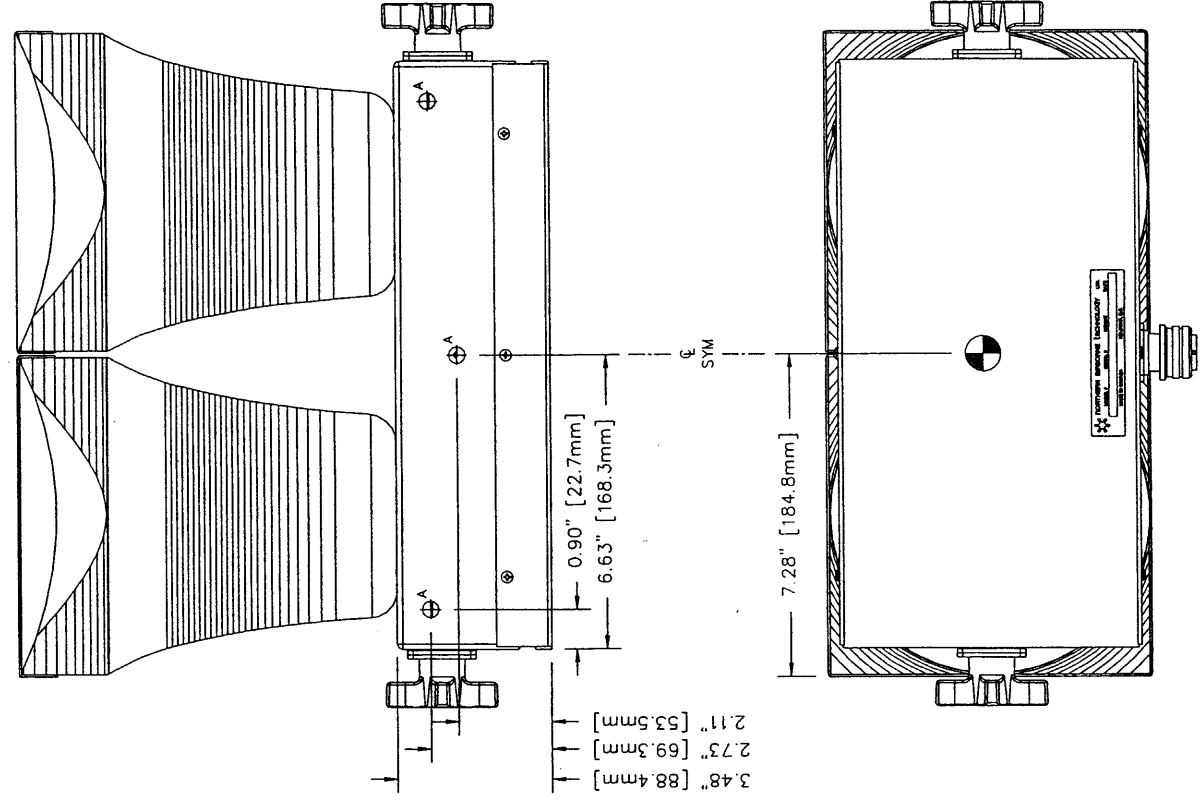

HOLE SCHEDULE		
IDENT	DIA	QTY COMMENTS
A	0.375	13
B	0.156	4

WEIGHT: 10.4 lbs. (4.7kg)  
 CENTER OF GRAVITY

PROPRIETARY AND CONFIDENTIAL TO NAT LTD.

TOLERANCES UNLESS STATED OTHERWISE	DIMENSIONS IN INCHES	DESIGNED	TGM	
0.X=+/-0.030	THIRD ANGLE PROJECTION	DRAWN	-	
0.XX=+/-0.010		DATE	JAN 15/99	
0.XXX=+/-0.005		CHECKED	NAT TRAP 11214	
0.XXXX=+/-0.002		APPROVED	NAT 107	
ANGLE=+/- 0.5 DEG.		MATERIAL		
FINISH		FILE	922-0101.DWG	
		DWG. TYPE	MECH. INSTALLATION	
		DWG. NO.	TS92\02XM\922-0	
<b>nat</b> NORTHERN AIRBORNE TECHNOLOGY LTD.				
SPEAKER ARRAY 2 BELL STANDARD WITH CLUTCH MOUNT				
REV.	SHEET	SIZE	CAGE CODE	PART NO.
1.01	1/1	B	3AB01	TS92-02XM

REVISIONS			
REV	DESCRIPTION	DATE	BY
1.01	ECR #1406 - ADDED MOUNTING HOLE DIMENSIONS, HOLE SCHEDULE AND NEW VIEW, FORMAT CHANGES.	JUN 1/99	TAT

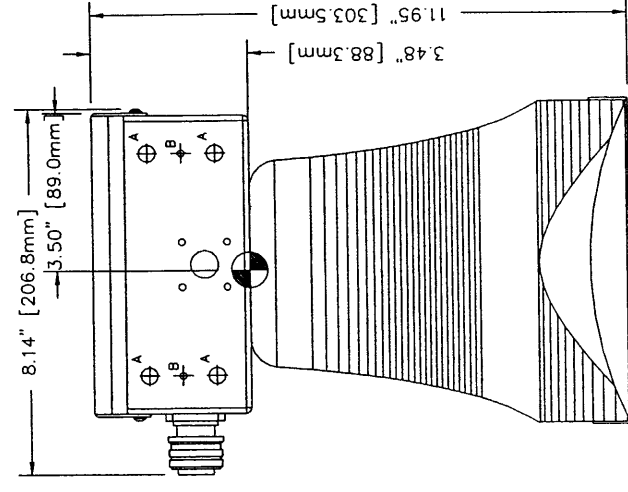
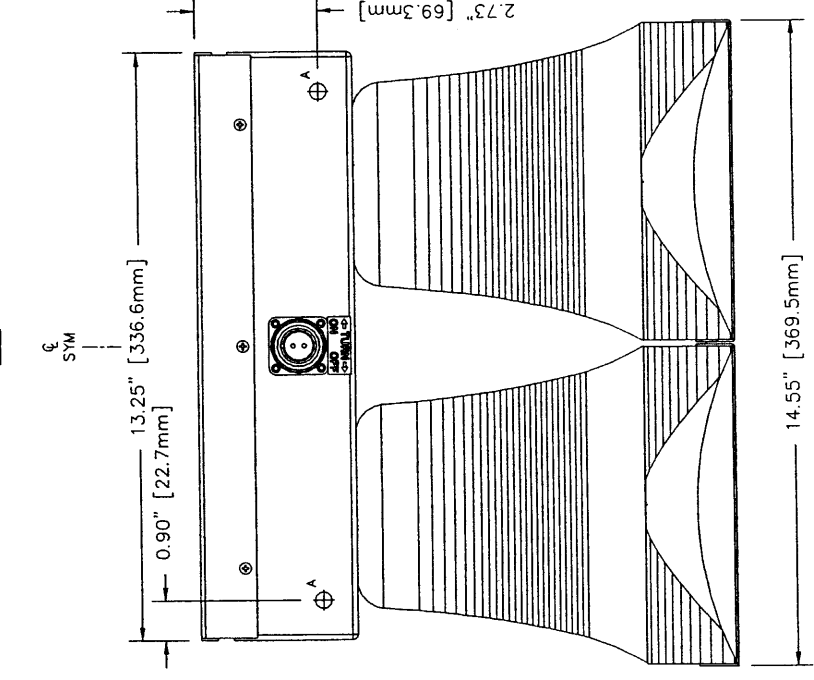
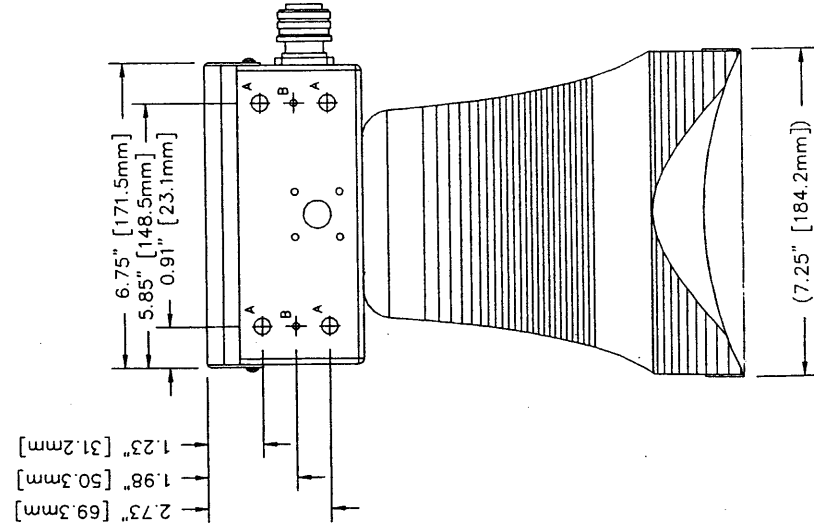
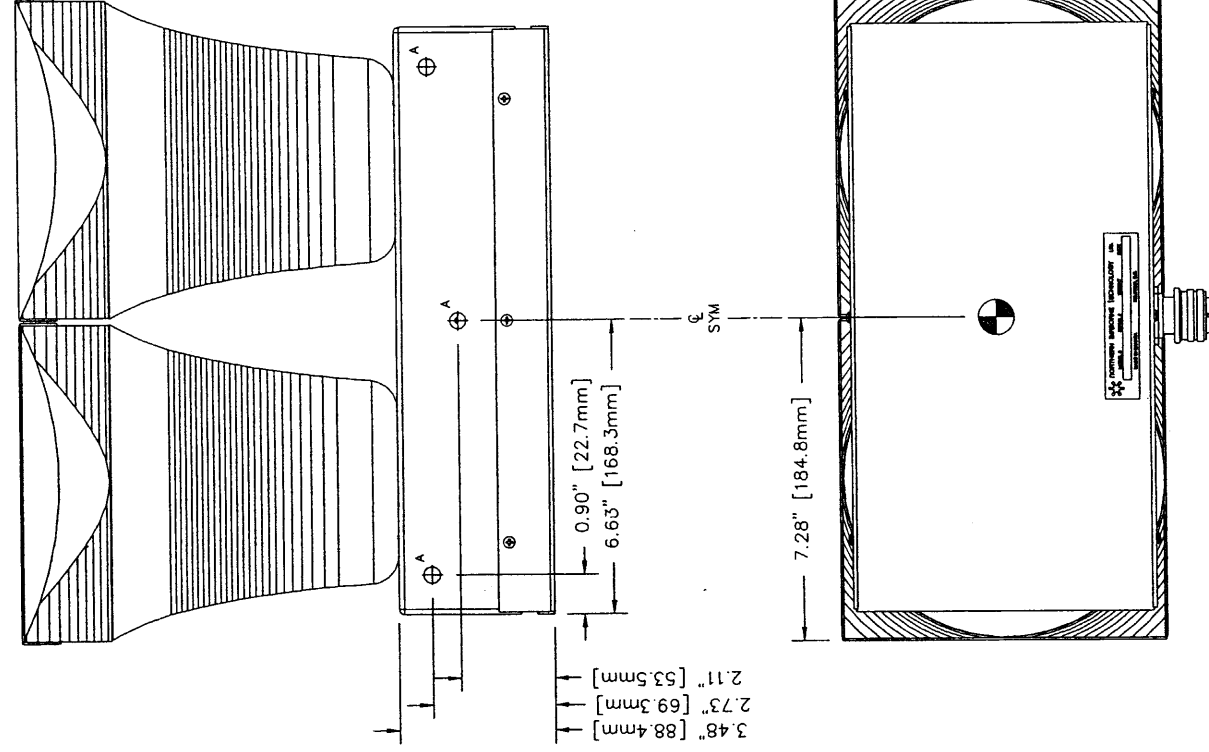

HOLE SCHEDULE		
IDENT	DIA	QTY COMMENTS
A	0.375	13
B	0.156	4

WEIGHT: 9 lbs. (4.1kg)  
 CENTER OF GRAVITY

PROPRIETARY AND CONFIDENTIAL TO NAT LTD.

TOLERANCES UNLESS STATED OTHERWISE	DIMENSIONS IN INCHES	DESIGNED	MWS/TAT
0.X=+/-0.030	THIRD ANGLE PROJECTION	DRAWN	
0.XX=+/-0.010		DATE	OCT 22/98
0.XXX=+/-0.005		CHECKED	NAT PROD NAT 14 214
0.XXXX=+/-0.002		APPROVED	NAT 107
ANGLE=+/- 0.5 DEG.		FILE	922-0101.DWG
MATERIAL		SIZE	B
FINISH		CAGE CODE	3AB01
		PART NO.	TS92-02XN
		REV.	1.01
		SHEET	1/1

nat NORTHERN AIRBORNE TECHNOLOGY LTD.

SPEAKER ARRAY  
 2 BELL STANDARD

DWG. NO. TS92\02XN\922-0

REVISIONS			
REV	DESCRIPTION	DATE	BY
1.01	ECR #1406 - ADDED MOUNTING HOLE DIMENSIONS AND HOLE SCHEDULE, FORMAT CHANGES.	JUN 2/99	TAT

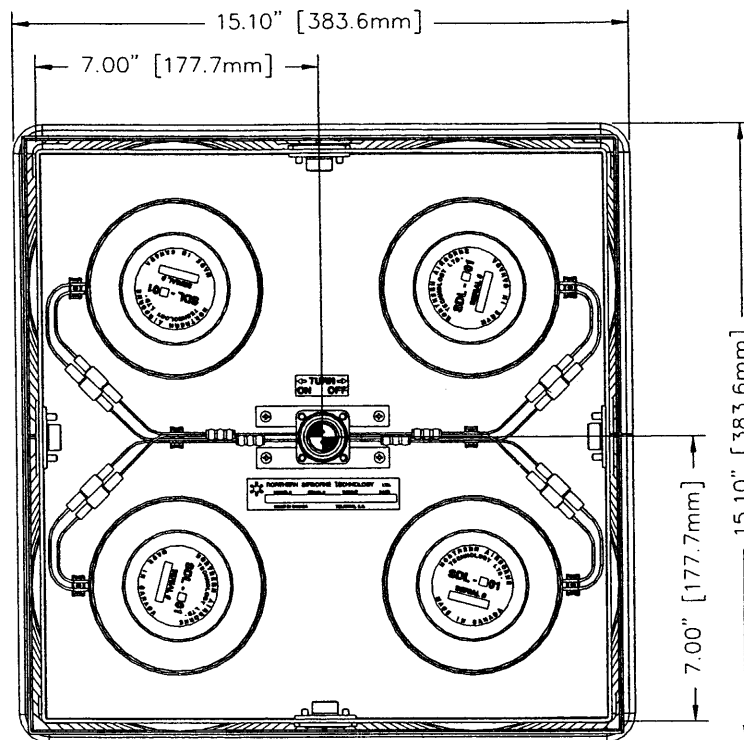

WEIGHT: 18 lbs. (8.2kg)  
 ● CENTER OF GRAVITY

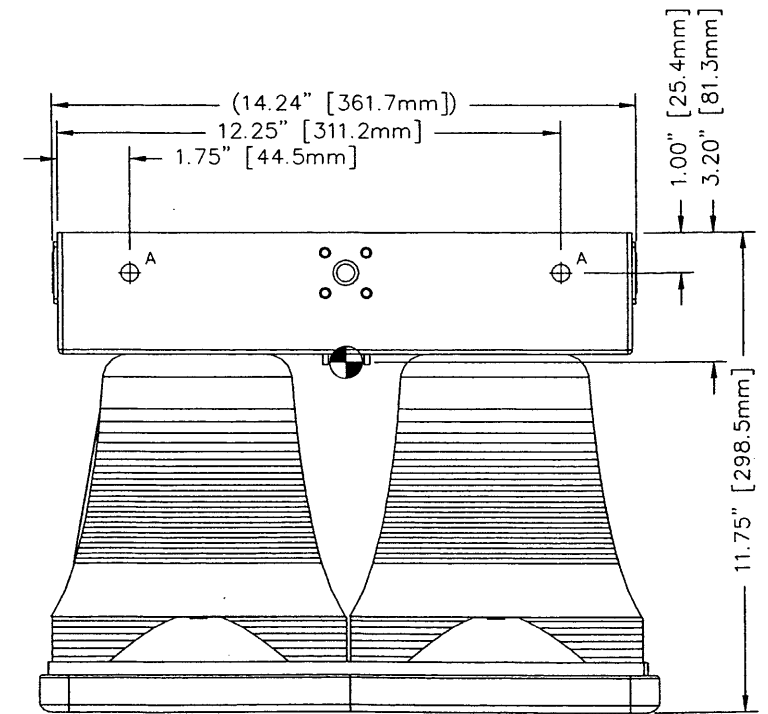
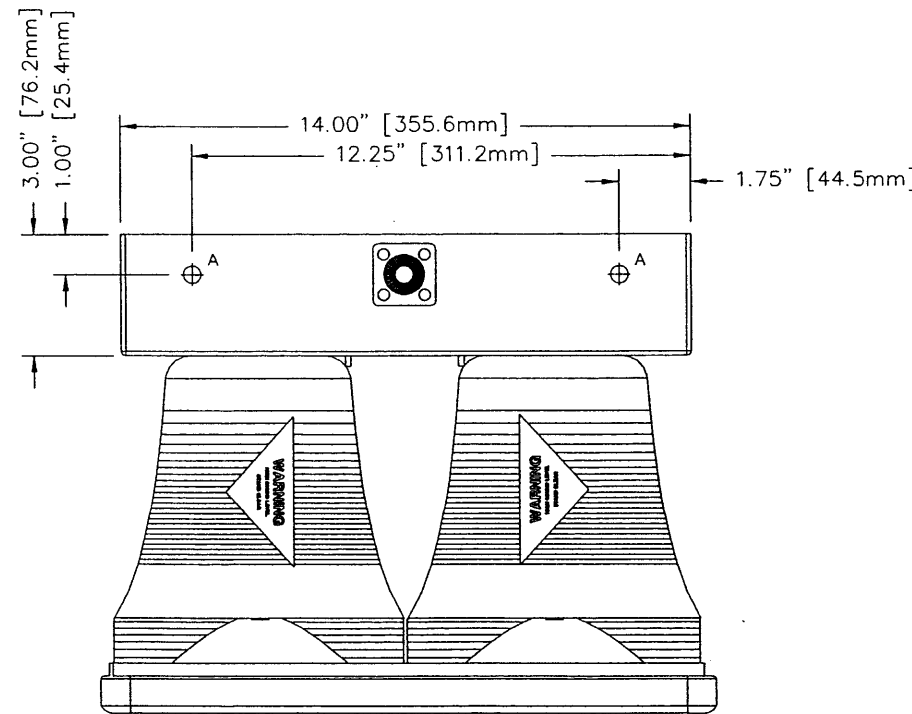
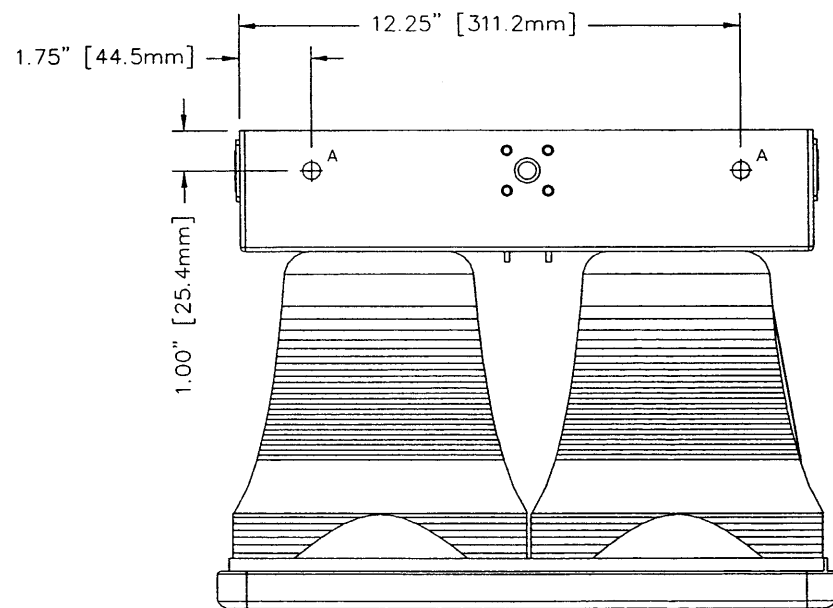

HOLE SCHEDULE			
IDENT	DIA	QTY	COMMENTS
A	0.438	8	

TOLERANCES UNLESS STATED OTHERWISE		DIMENSIONS IN INCHES		DESIGNED -		DRAWN MWS/TAT		DATE OCT 22/98		CHECKED NAT 112 NAT 214		APPROVED NAT 107		FILE 922-0101.DWG	
0.X=+/-0.030		THIRD ANGLE PROJECTION		DRAWN MWS/TAT		DATE OCT 22/98		CHECKED NAT 112 NAT 214		APPROVED NAT 107		FILE 922-0101.DWG		DWG. TYPE MECH. INSTALLATION	
0.XX=+/-0.010		0.XXX=+/-0.005		0.XXXX=+/-0.002		ANGLE=+/- 0.5 DEG.		MATERIAL		FINISH		SIZE B		CAGE CODE 3AB01	
0.XXX=+/-0.005		0.XXXX=+/-0.002		ANGLE=+/- 0.5 DEG.		MATERIAL		FINISH		SIZE B		CAGE CODE 3AB01		PART NO. TS92-04XN	
0.XXXX=+/-0.002		ANGLE=+/- 0.5 DEG.		MATERIAL		FINISH		SIZE B		CAGE CODE 3AB01		PART NO. TS92-04XN		REV. 1.01	
ANGLE=+/- 0.5 DEG.		MATERIAL		FINISH		SIZE B		CAGE CODE 3AB01		PART NO. TS92-04XN		REV. 1.01		SHEET 1/1	
MATERIAL		FINISH		SIZE B		CAGE CODE 3AB01		PART NO. TS92-04XN		REV. 1.01		SHEET 1/1		DWG. NO. TS92\04XN\922-0	
FINISH		SIZE B		CAGE CODE 3AB01		PART NO. TS92-04XN		REV. 1.01		SHEET 1/1		DWG. NO. TS92\04XN\922-0			

PROPRIETARY AND CONFIDENTIAL TO NAT LTD.

**nat** NORTHERN AIRBORNE TECHNOLOGY LTD.

TITLE  
 SPEAKER ARRAY  
 4 BELL STANDARD

SIZE B CAGE CODE 3AB01 PART NO. TS92-04XN REV. 1.01 SHEET 1/1

DWG. TYPE MECH. INSTALLATION DWG. NO. TS92\04XN\922-0

REVISIONS			
REV	DESCRIPTION	DATE	BY
1.01	ECR #1406 - ADDED MOUNTING HOLE DIMENSIONS, HOLE SCHEDULE, FORMAT CHANGES.	JUN 2/99	TAT

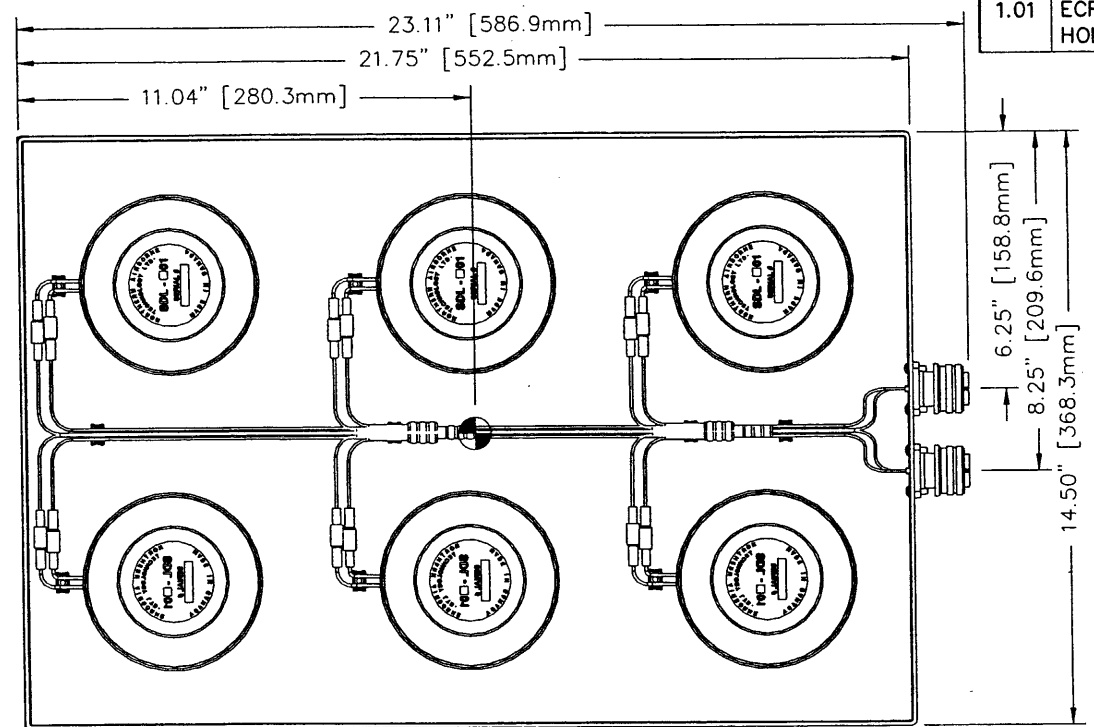

● CENTER OF GRAVITY  
WEIGHT: 24.5 lbs. (11.11kg)

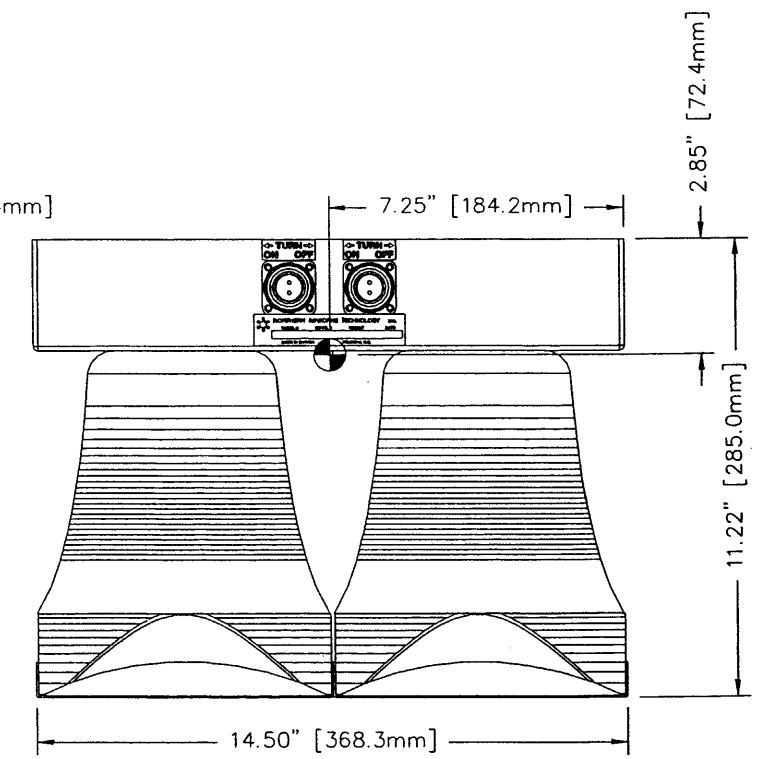
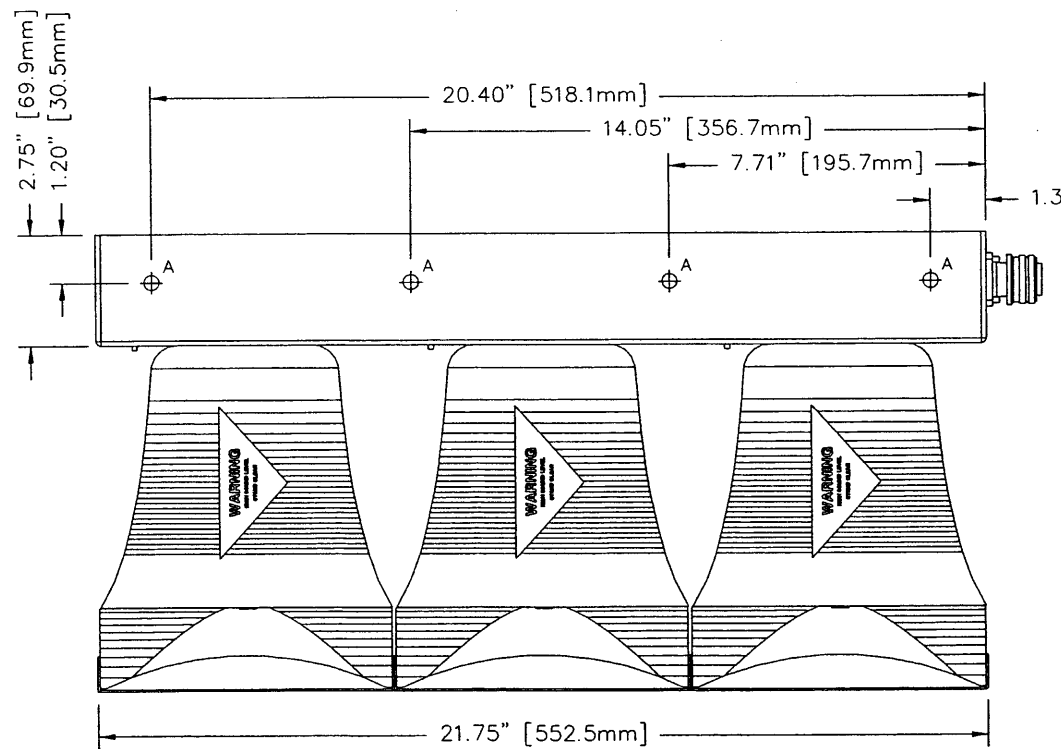
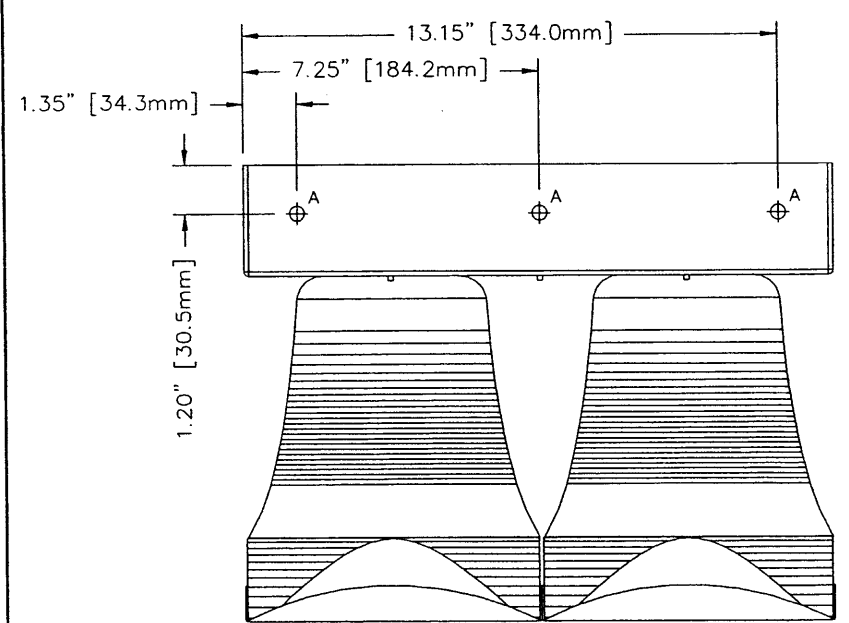

PROPRIETARY AND CONFIDENTIAL TO NAT LTD.

HOLE SCHEDULE			
IDENT	DIA	QTY	COMMENTS
A	0.375	11	

TOLERANCES UNLESS STATED OTHERWISE 0.X=+/-0.030 0.XX=+/-0.010 0.XXX=+/-0.005 0.XXXX=+/-0.002 ANGLE=+/- 0.5 DEG.	DIMENSIONS IN INCHES THIRD ANGLE PROJECTION	DESIGNED - DRAWN MWS/TAT DATE OCT 14/98 CHECKED NAT PRAT 11-214 APPROVED NAT 107	NAT NORTHERN AIRBORNE TECHNOLOGY LTD.	
MATERIAL			TITLE SPEAKER ARRAY 6 BELL STANDARD	
FINISH			SIZE B	CAGE CODE 3AB01
			PART NO. TS92-06XN	REV. 1.01
		FILE 922-0101.DWG	DWG. TYPE MECH. INSTALLATION	DWG. NO. TS92\06XN\922-0
				SHEET 1/1

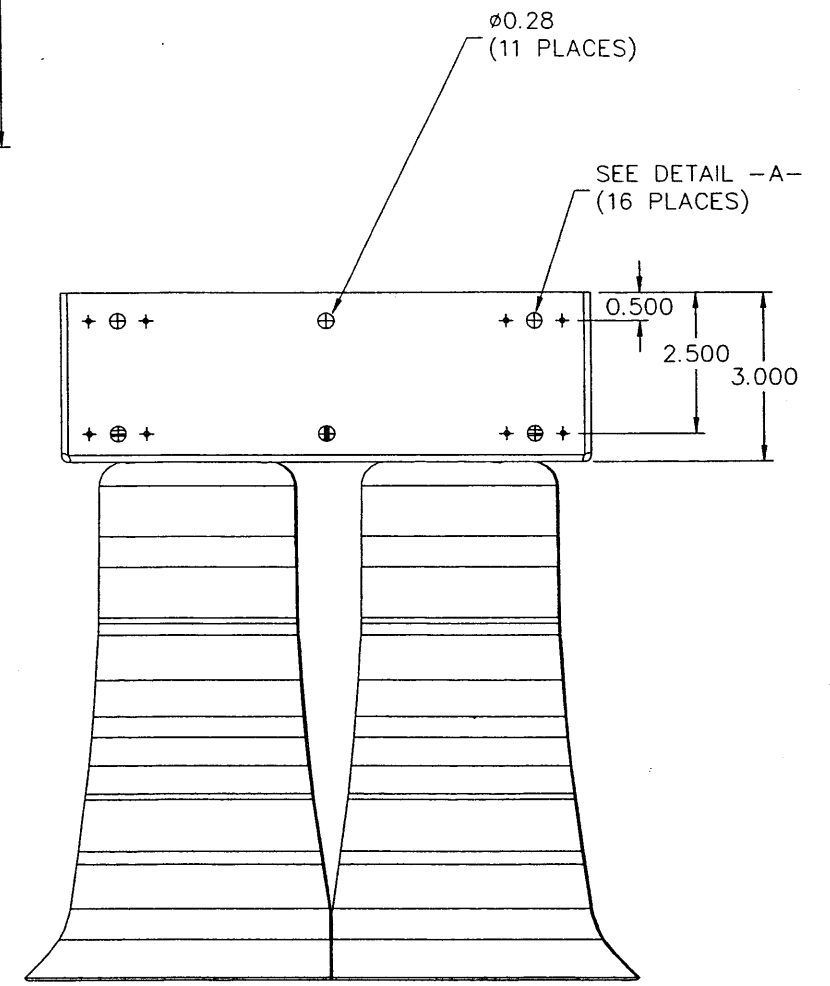
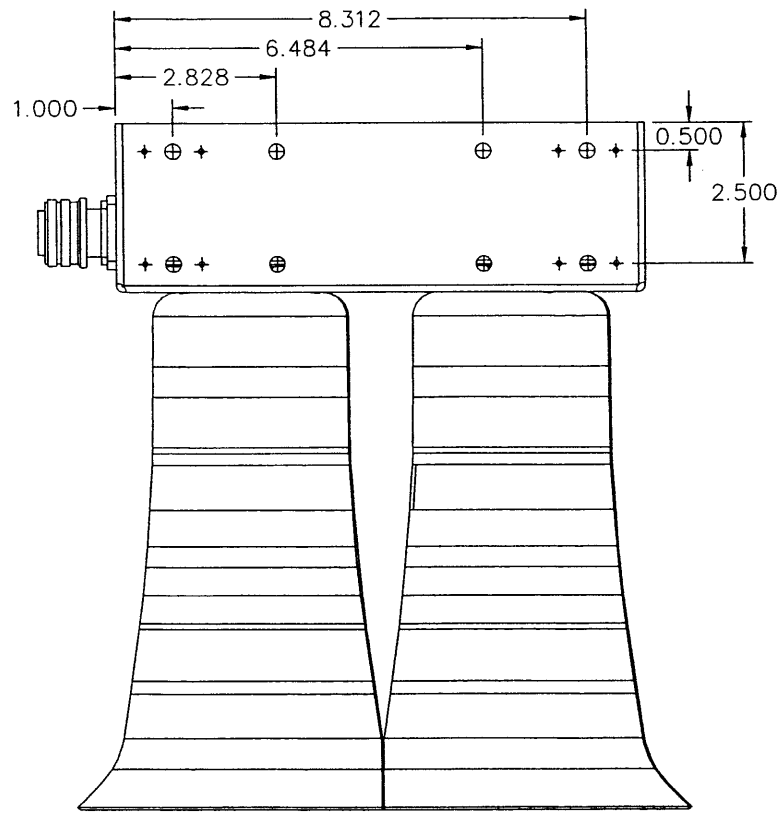
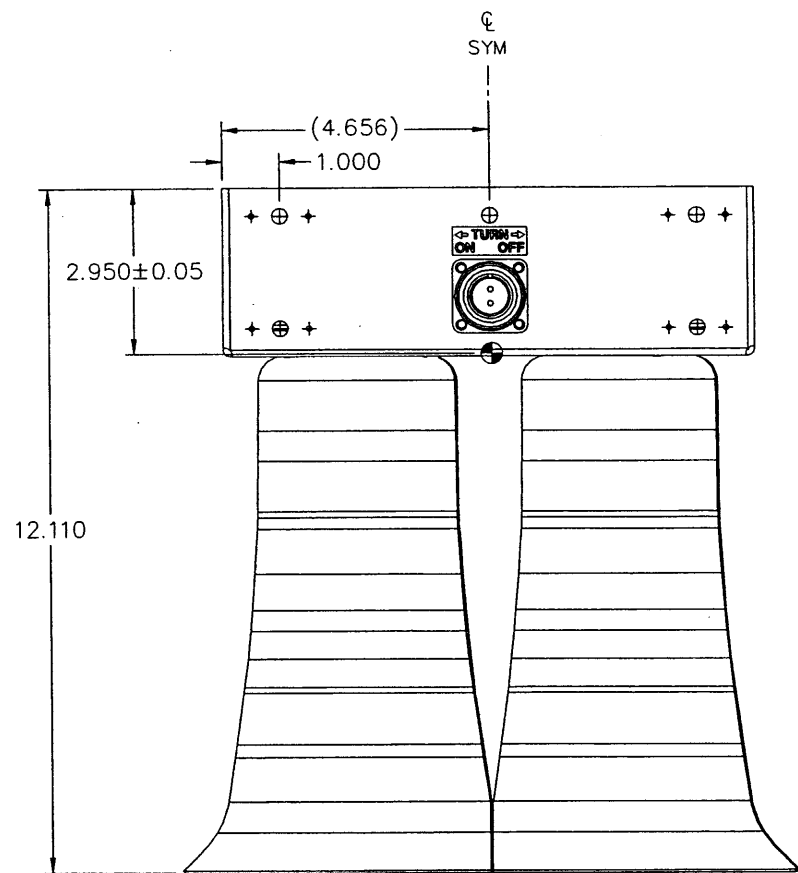
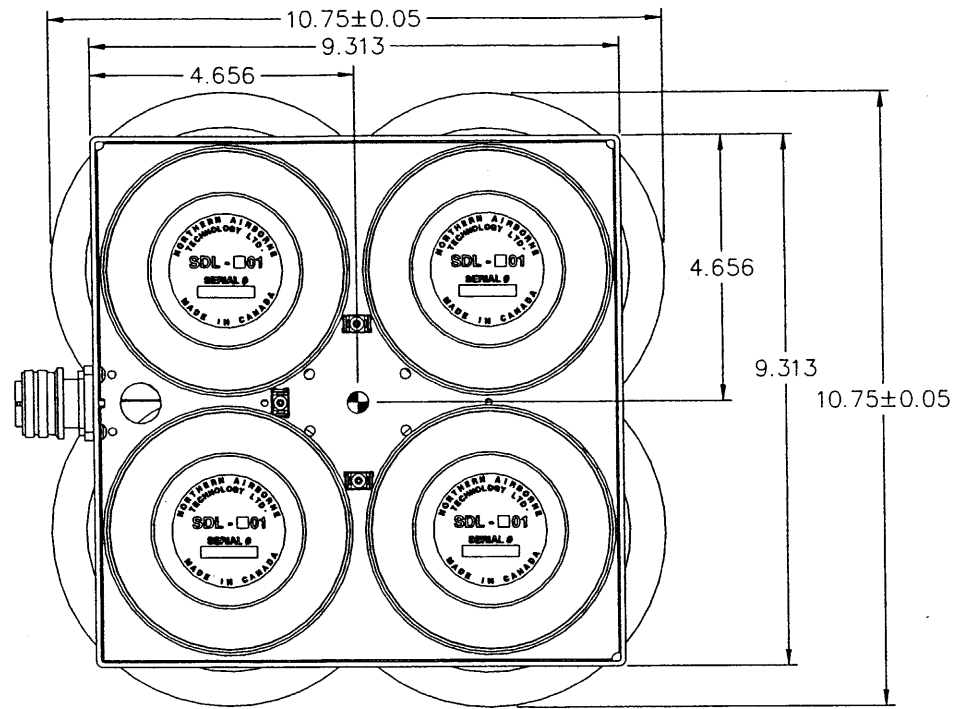
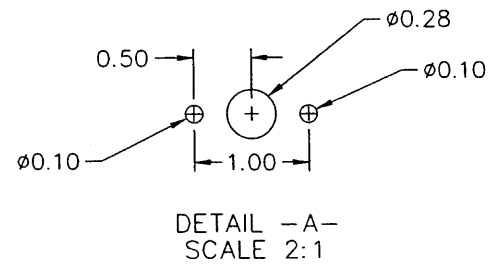

● CENTER OF GRAVITY  
WEIGHT: 16 lbs. (7.2kg)

PROPRIETARY AND CONFIDENTIAL TO NAT LTD.

TOLERANCES UNLESS STATED OTHERWISE 0.X=+/-0.030 0.XX=+/-0.010 0.XXX=+/-0.005 0.XXXX=+/-0.002 ANGLE=+/- 0.5 DEG.	DIMENSIONS IN INCHES THIRD ANGLE PROJECTION	DESIGNED	-				
		DRAWN	TAT/TGM				
MATERIAL	FINISH	DATE	JAN 4/99				
		CHECKED	NAT PROD. 1/214				
		APPROVED	NAT 107				
		FILE	922-0100.DWG	DWG. TYPE	MECH. INSTALLATION	DWG. NO.	TS93\04XN\922-0
		SIZE	B	CAGE CODE	3AB01	PART NO.	TS93-04XN
		REV.	1.00	SHEET	1/1		
		<p>●nat NORTHERN AIRBORNE TECHNOLOGY LTD.</p> <p>TITLE: SPEAKER ARRAY 4 BELL CLOVERLEAF</p>					

WEIGHT: 7.75 lbs. (3.5 kg)  
 ● CENTER OF GRAVITY

HOLE SCHEDULE			
IDENT	DIA	QTY	COMMENTS
A	0.281	19	

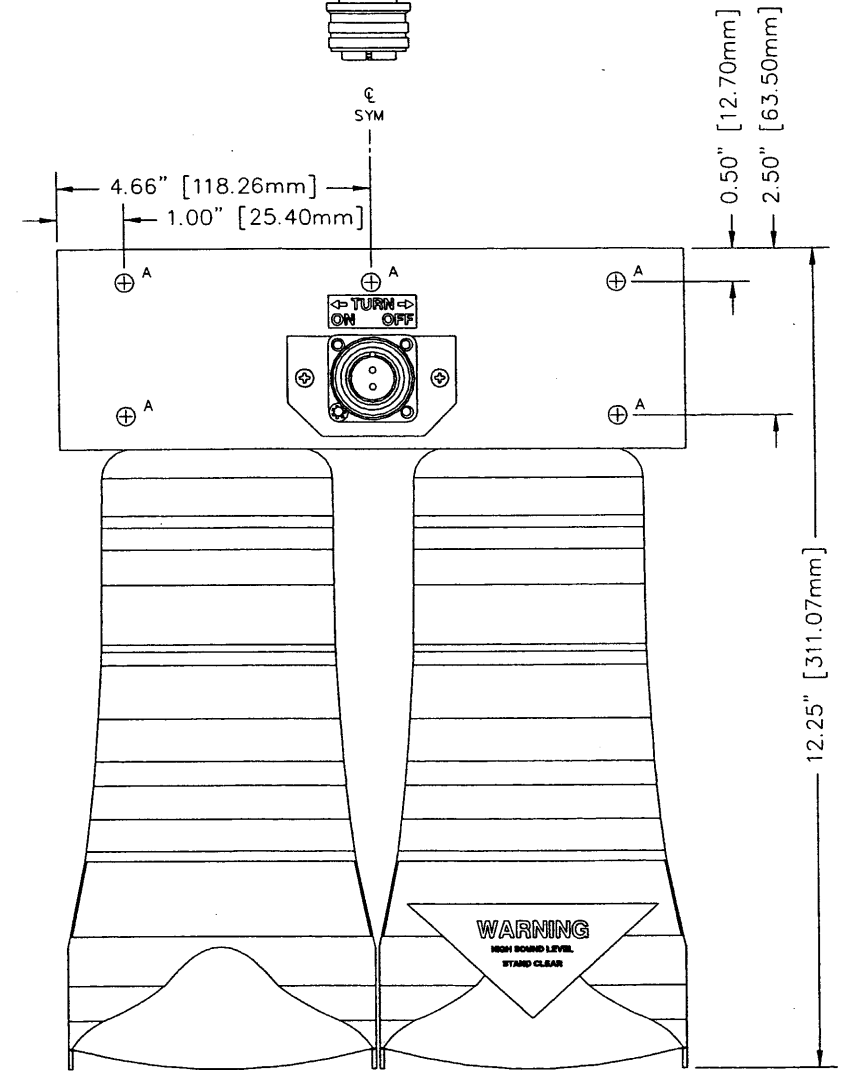
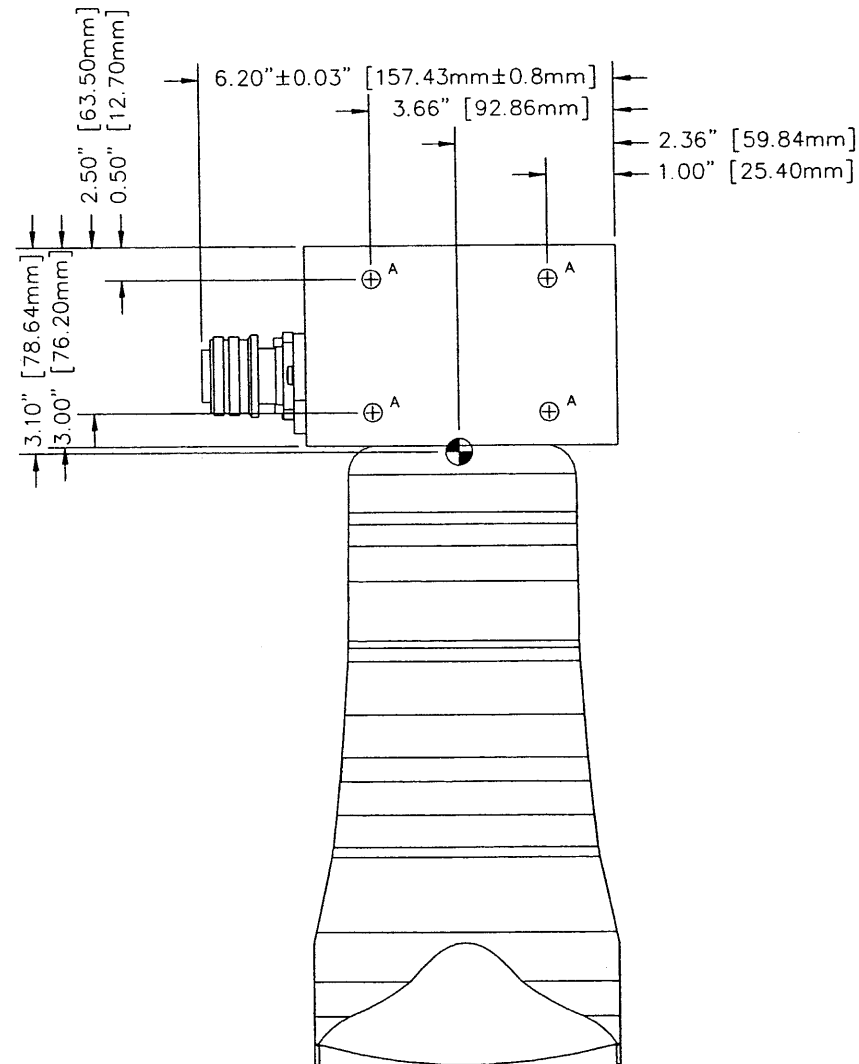
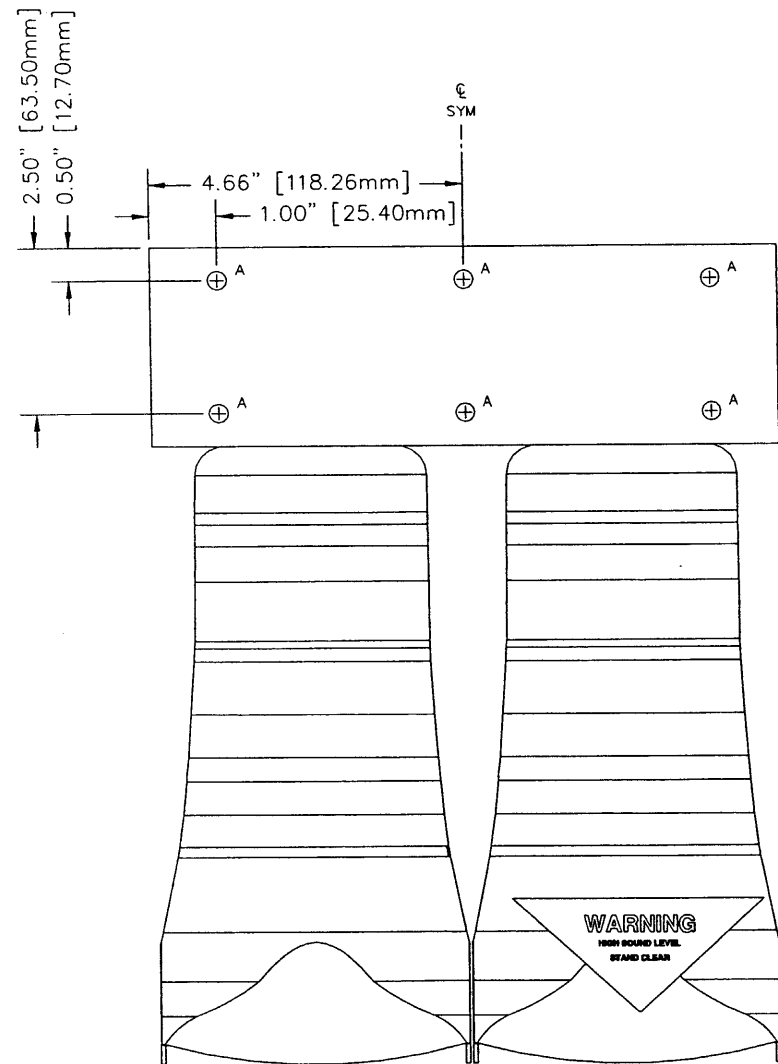
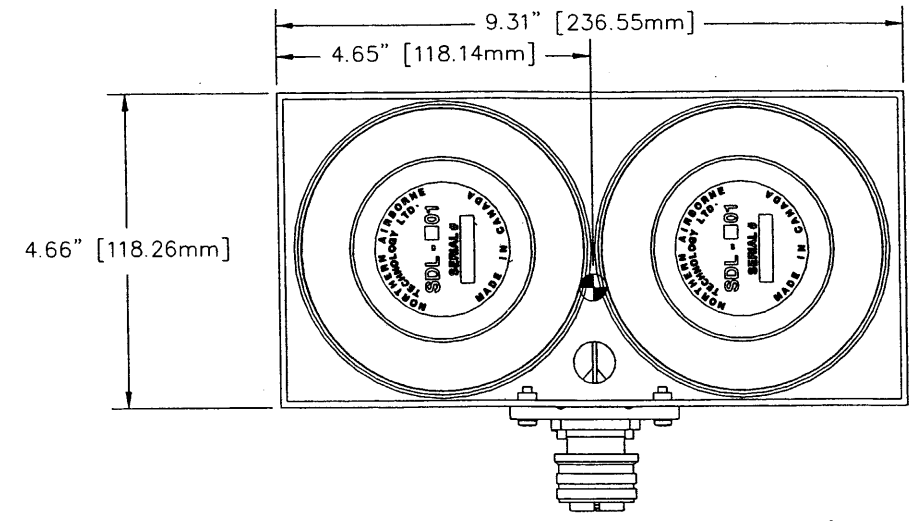

PROPRIETARY AND CONFIDENTIAL TO NAT LTD.

TOLERANCES UNLESS STATED OTHERWISE 0.X=+/-0.030 0.XX=+/-0.010 0.XXX=+/-0.005 0.XXXX=+/-0.002 ANGLE=+/- 0.5 DEG.	DIMENSIONS IN INCHES	DESIGNED	● <b>nat</b> NORTHERN AIRBORNE TECHNOLOGY LTD.								
	THIRD ANGLE PROJECTION	DRAWN	TAT	TITLE							
MATERIAL	FINISH	DATE	JUN 9/99	SPEAKER ARRAY							
		CHECKED	NAT PRO 112214	2 BELL MINI							
APPROVED	NAT 107	SIZE	B	CAGE CODE	3AB01	PART NO.	TS94-02XN	REV.	1.00	SHEET	1/1
FILE		922-0100.DWG	DWG. TYPE	MECH. INSTALLATION	DWG. NO.	TS94\02XN\922-0					

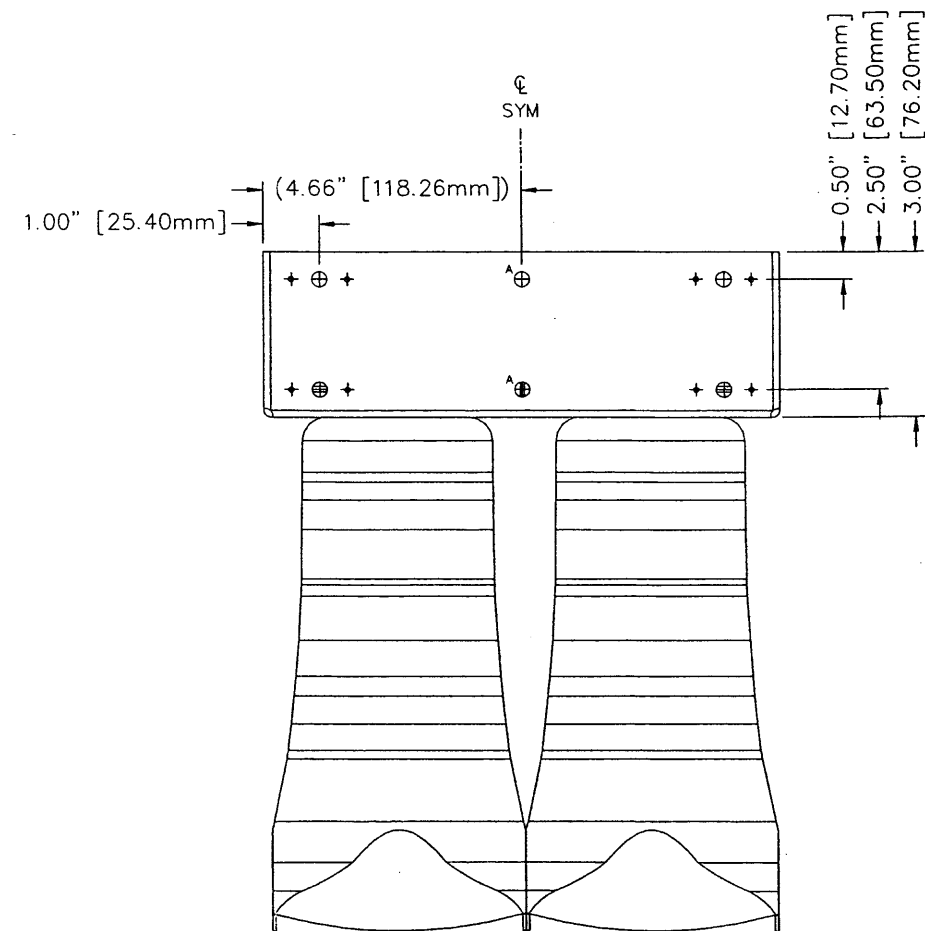
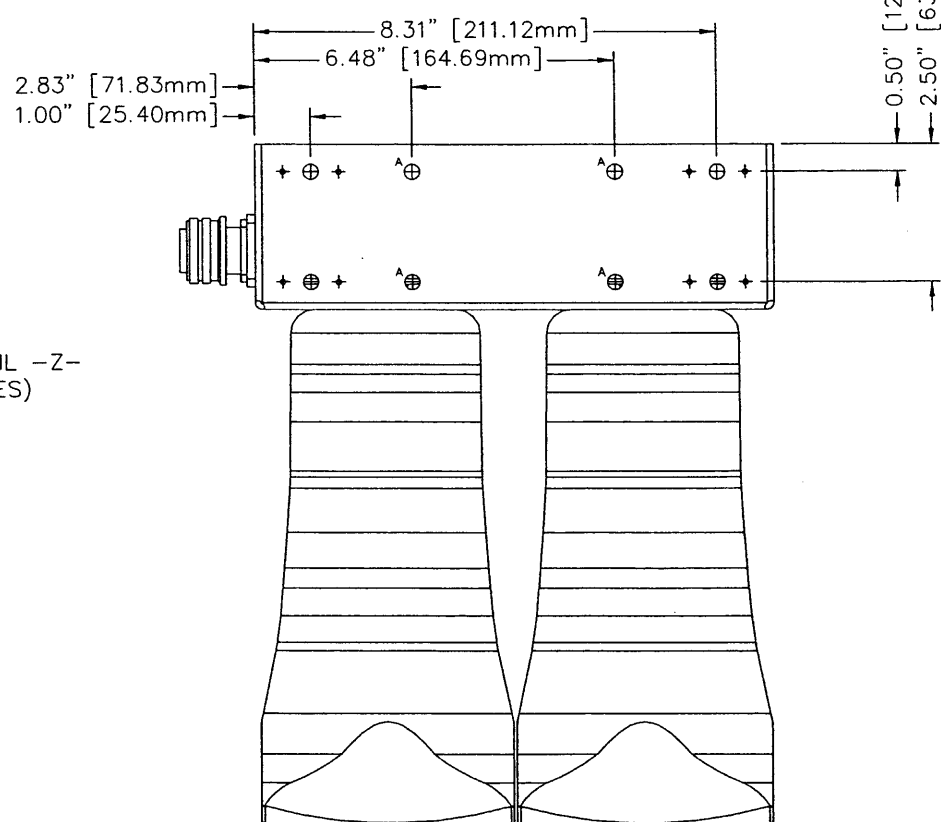
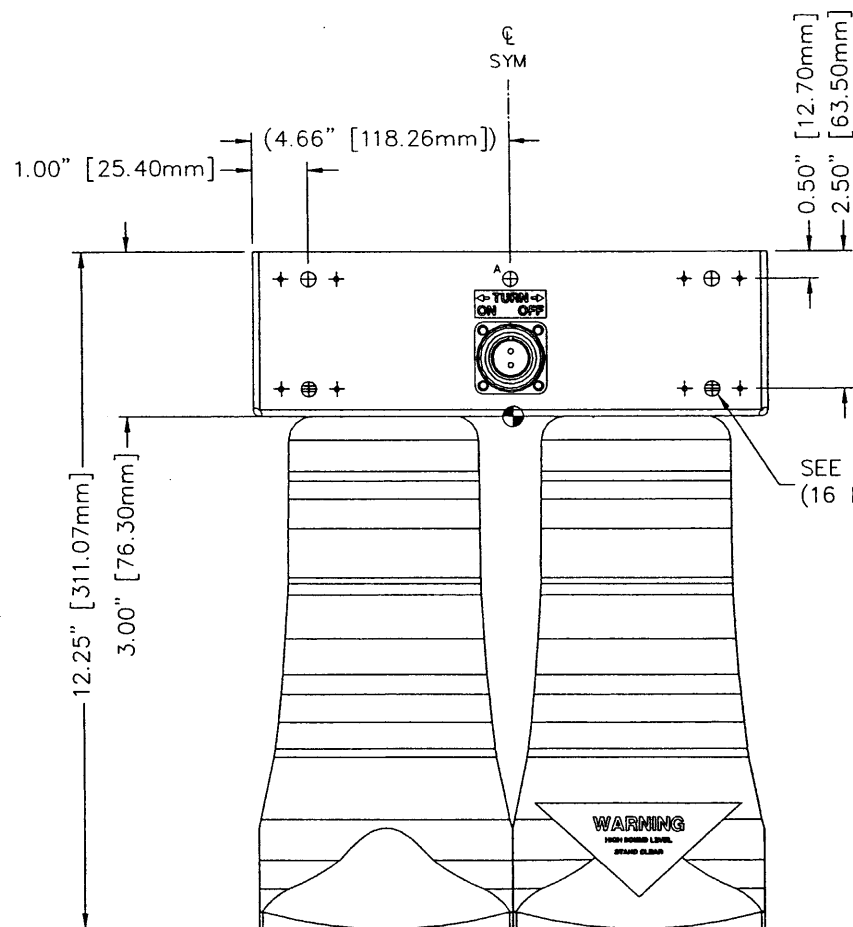
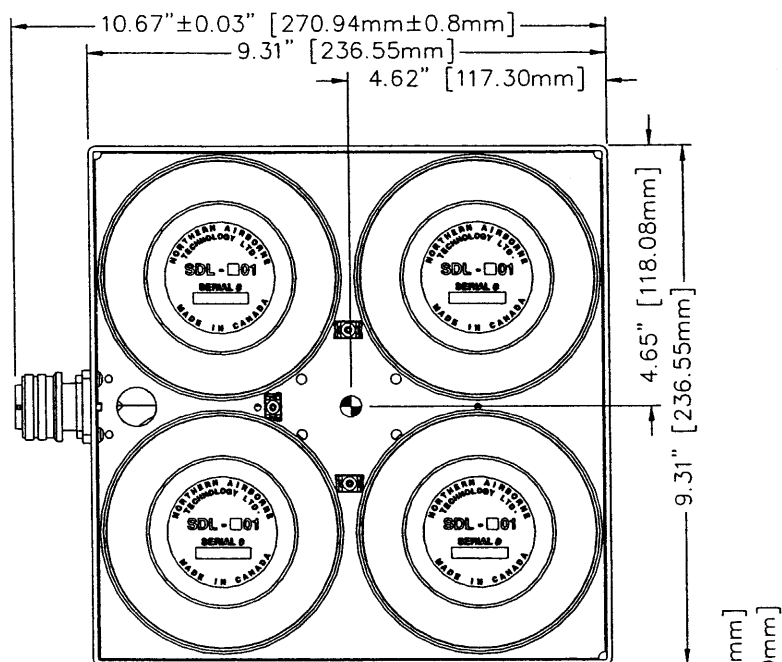
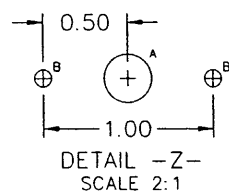

PROPRIETARY AND CONFIDENTIAL TO NAT LTD.

HOLE SCHEDULE			
IDENT	DIA	QTY	COMMENTS
A	0.28	27	
B	0.10	32	
Z	-	16	SEE DETAIL -Z-

⊙ CENTER OF GRAVITY  
WEIGHT: 16.0 lbs. (7.2 kg)

TOLERANCES UNLESS STATED OTHERWISE 0.X=+/-0.030 0.XX=+/-0.010 0.XXX=+/-0.005 0.XXXX=+/-0.002 ANGLE=+/- 0.5 DEG.	DIMENSIONS IN INCHES THIRD ANGLE PROJECTION	DESIGNED - DRAWN TAT DATE JUN 9/99 CHECKED NAT PROD 112 APPROVED NAT 107	NAT NORTHERN AIRBORNE TECHNOLOGY LTD.	
MATERIAL		TITLE SPEAKER ARRAY 4 BELL MINI		
FINISH		SIZE B	CAGE CODE 3AB01	PART NO. TS94-04XN
FILE 922-0100.DWG		DWG. TYPE MECH. INSTALLATION	DWG. NO. TS94\04XN\922-0	REV. 1.00 SHEET 1/1

## Section 3.0 Operation

### 3.1 Operation Specifics

---

The TS9x Lightweight Speaker Array has no normal user operational aspects.

End of section 3.0