



**SM50**

**AMS50-000  
Stereo Audio Panel with Marker**



## INSTALLATION AND OPERATION MANUAL

REV 4.00 November 12, 2003

Northern Airborne Technology Ltd.  
1925 Kirschner Road  
Kelowna BC, Canada  
V1Y 4N7

Telephone (250) 763-2232  
Facsimile (250) 762-3374

Copyright 2003 by Northern Airborne Technology



Periodically NAT will release manual amendments. In order to maintain the most accurate and up to date manual these amendments should be carried out immediately upon receipt and recorded on the following amendment record.

AMENDMENT RECORD				
Amendment Number	Amendment Date	Section(s) Changed	Date Entered	Entered By
1	Jan 18\05	2		<b>Performed at factory</b>
2	Mar 20\06	2, 3		<b>Performed at factory</b>

Insert any Amendment Instruction sheets after this page.



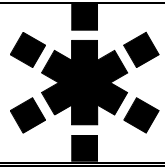

**nat**<sup>®</sup>

**INSTALL\_OPS  
MANUAL AMENDMENT**

**Manual: SM50 (AMS50)**

**Amendment #: 2**

**Document # SM50\Install\_Ops\809-0002**

**Amendment Date: Mar 20, 2006**

The purpose of this amendment is to correct the PTT function description and change a connector reference.

**Amendment Instructions:**

1	Remove Pages	Replace With Pages
	2-9 and 2-10 Rev 4.00 Amendment # 1	2-9 and 2-10 Rev 4.00 Amendment # 2
	3-1 and 3-2 Rev 4.00	3-1 and 3-2 Rev 4.00 Amendment # 2

2 Update the Amendment Record sheet at the front of the manual.

3 Insert this page into the manual after the Amendment Record sheet (page ii).

**Manual Amendment ends after the following amended pages**



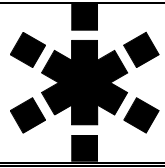

**nat**

**INSTALL\_OPS  
MANUAL AMENDMENT**

**Manual: SM50 (AMS50)**

**Amendment #: 1**

**Document # SM50\Install\_Ops\809-0001**

**Amendment Date: Jan 18, 2005**

The purpose of this amendment is to add the Environmental Qualification Form (521-0) to section 2.5 and to update section 2.3.3 Cable and Wiring statement paragraph 1.

1	Remove Pages	Replace With Pages
	2-1, 2-2, 2-9 and 2-10 Rev 4.00	2-1, 2-2, 2-9 and 2-10 Amendment #1 Rev 4.00

2	Remove Drawings/Documents (Section 2)	Replace or add Drawings/Documents (Section 2)
	-	AMS50\000\521-0 Rev 1.00

**Note:** Ensure that all drawings are inserted in the order shown on the latest drawing lists.

3 Update the Amendment Record sheet at the front of the manual.

4 Insert this page into the manual after the Amendment Record sheet (page ii).

Manual Amendment ends after the following amended pages



## Table of Contents

Section	Title	Page
1.0	Description	
1.1	Introduction	1-1
1.2	Purpose of Equipment	1-1
1.3	Features	1-1
1.4	Specifications	1-2
1.4.1	Electrical Specifications	1-2
1.4.2	Physical Specifications	1-4
1.4.3	Environmental Specifications	1-4
1.4.4	Certification	1-4
1.5	Unit Nomenclature	1-5
1.5.1	Marker Beacon	1-5
1.5.2	Special Features	1-5
1.5.3	Cosmetic Differences	1-5
2.0	Installation	
2.1	Introduction	2-1
2.2	Unpacking and Inspection	2-1
2.2.1	Warranty	2-1
2.3	Installation Procedures	2-1
2.3.1	Warnings	2-1
2.3.2	Cautions	2-2
2.3.3	Cabling and Wiring	2-2
2.3.4	Accessories Supplied	2-3
2.3.5	Mechanical Installation	2-4
2.3.6	Installation Options and Features	2-5
2.3.7	Adjustments	2-7
2.3.8	Post-Installation Checks	2-9
2.4	Continued Airworthiness	2-10
2.5	Installation Drawings	2-10



### 3.0 Operation

---

3.1	Introduction	3-1
3.2	Controls and Indicators	3-1
3.2.1	Transmit Operation	3-1
3.2.2	Receive Functions	3-2
3.2.3	ICS Functions	3-3
3.2.4	Speaker and Test Buttons	3-4
3.2.5	ICS and VOX Volume Control	3-5
3.2.6	Marker Beacon	3-6
3.2.7	Automatic Fail-safe	3-6
3.2.8	Optional Features	3-7
3.3	Start-Up Selections	3-7



## Section 1.0 Description

### 1.1 Introduction

---

This manual contains information on the AMS50-000 Stereo Audio Panel.

Information in this section consists of purpose of equipment, features and specifications.

### 1.2 Purpose of Equipment

---

The AMS50-000 is a full-function stereo audio panel with a six-place, voice-activated (VOX) intercom and an optional built-in Marker Beacon receiver. The front panel controls feature clean responsive switching for crucial audio management. Transmitter and receiver selections are quick and precise using soft touch push-buttons. Positive feedback is provided in two formats: tactile and visual (colored LED's).

### 1.3 Features

---

Radio functions include independently selectable transmit capability for Pilot and Co-pilot on 3 COM radios. Pilot's transmit selection also has remote capability (yoke or cyclic). Receive audio selections include: COM1, COM2, COM3, MKR, NAV1, NAV2, DME and AUX. COM3 is configurable at time of installation for use with an aviation phone.

The built-in six-place VOX intercom system with ALL, CREW, and PLT ISO modes, features NAT's Active Noise Filtering (ANF™) system. This advanced technology filters out unwanted ambient noise entering the intercom channel, thus better isolating the human voice. Clear, clean intercom communications result in a safer and more comfortable flight.

Wind, engine and other fatigue noises are significantly reduced within the intercom system by utilizing independent microphone circuits. By 'turning on' only the active microphone, internal communications are quieter and less stressful.

Protection circuits help to prevent accidental damage from overvoltage and reverse voltage conditions.

Accommodation is provided for two (2) direct unswitched inputs for functions such as telephone ringer, Rad Alt, GPS alerts, and an Option Select input controls firmware related functions (i.e. Karaoke).

Automatic fail-safe operation is provided in the event of a power failure. The Pilot is routed directly to COM1 and the unswitched direct audio inputs. This mode can also be manually selected using the OFF (EMG) switch (see section 3.2.5.3 of this manual.)

## 1.4 Specifications

### 1.4.1 Electrical Specifications

#### Power Supply

Input voltage:	11-33 Vdc @ 3.0 A max. (one input for both) Note: For emergency voltages below 11 Vdc, the Manual Fail-safe mode must be used.
Internal supply:	± 8 Vdc for ICS and music to phones, + 12 Vdc for speaker and front panel lighting + 5 Vdc for logic circuitry
Nominal Lighting Voltage:	27.5 Vdc @ 10 mA max } 13.8 Vdc @ 10 mA max } two separate inputs

#### Input Signals

Microphone:	6 inputs, 250 mVrms into 150 Ω (Fixed)
Receive Audio:	3 COM inputs , 5 NAV inputs. (COM3 configurable for use with aviation phone). 2.5 Vrms into 510 Ω (Fixed)
RX detection:	50 mVrms min
Sidetone Level:	2 mW (1 Vrms) min into 510 Ω
Keylines:	Two TX keys (Pilot and Co-pilot).
Music input:	Stereo input, switchable between portable cassette/CD player or rack mounted CD player.
Portable Cassette or CD:	400 mVrms (Nominal) into 610 Ω 250 mVrms to 700 mVrms
Rack mounted CD Player:	2.5 Vrms (Nominal) into 3.5 kΩ 1.0 Vrms to 4.5 Vrms

#### Output Signals

Headphones:	6 stereo outputs, at full volume, > 70 mW into 300 Ω, < 10% THD each side. (> 100 mW into 150 Ω).
ICS Volume Range:	40 ± 5 dB
Radio Audio Adjustments:	Controlled at each radio source.
Speaker:	Adjustable: 0-7 W into 4 Ω @ 27.5 Vdc supply 0-3.5 W into 4 Ω @ 13.8 Vdc supply
COM MIC	3 outputs @ 250 mVrms into 150 Ω each, controlled by either PLT or CPLT.
PA MIC	1 output @ 250 mVrms into 150 Ω, controlled by either PLT or CPLT.

Performance/Function

TSO-C50c	RTCA DO-170 Class II
Rated Output Power	40 mW into 300 $\Omega$ (each phone channel)
Rated Speaker Output Power	7 W into 4 $\Omega$ (3.5 W into 8 $\Omega$ ) 2 W into 4 $\Omega$ @ 13.8 Vdc power
Audio freq. response:	
Receive	< 3 dB from 350 - 6000 Hz
Intercom	< 3 dB from 350 - 3000 Hz
Music	< 3 dB from 50 - 15000 Hz
Speaker	< 3 dB from 450 - 6000 Hz
Distortion:	< 10% at rated power
Input - Input crosstalk:	> 30 dB
Input - Output crosstalk:	> 50 dB
Input - Mic crosstalk:	< 1.0 mVrms
Audio noise:	< -50 dB
Output Regulation:	< 3 dB output power variance < 10% THD
Audio Communication:	Loud & Clear
ICS Volume controls:	40 $\pm$ 5 dB
Receive Input impedance:	510 $\Omega$ $\pm$ 5%
Mic Input impedance:	150 $\Omega$ $\pm$ 5%
Music Input impedance:	610 $\Omega$ $\pm$ 5% and 3.5 k $\Omega$ $\pm$ 10%

Marker Beacon

TSO-C35d	Class A
Receiver Frequency:	75 MHz
Sensitivity:	
Lo	1000 $\mu$ V
Hi	200 $\mu$ V
Selectivity:	6 dB (min.) @ $\pm$ 10 kHz 40 dB (max.) @ $\pm$ 200 kHz
Input Impedance:	50 $\Omega$ (ohm)
Lamp Output:	400 Hz Blue indicator marked 'O' (Outer) 1300 Hz Amber indicator marked 'M' (Middle) 3000 Hz White indicator marked 'A' (Airways)
External lamps:	Active Lo 125 mA max. sink current.

Middle Marker sense:	Active Hi (4.5 Vdc) during Middle Marker acquisition, for autopilot.
Audio level:	Phones audio level side adjustable: 0.5 - 2.5 Vrms.
Distortion:	<30% (Input signal from receiver threshold to 50 mV.)

#### 1.4.2 Physical Specifications

---

Enclosure size behind panel:	
Height	1.13" (28.7 mm) max.
Length	6.70" (170.2 mm) max.
Width	6.25" (158.8 mm) max.
Weight	2 lb. (909 g)
Mounting	Tray mount with center securing rod - 3/32" hex (Allen) key.
Connectors	44-pin card edge connectors. Crimp contacts #18-22 AWG and #22-26 AWG gold plating over nickel plate.
Material/Finish	
Chassis & Cover	Brushed aluminum with chromate conversion.
Tray	Stainless Steel

#### 1.4.3 Environmental Specifications

---

Temperature:	
Operating	-20°C to +55°C
Survival	-55°C to +85°C
Altitude	50,000 ft
Humidity	95%
Shock, Crash Safety	6g, 20g
DO-138	[Z]

RTCA DO-160D Env. Cat. [A1D1]-BAB[(SBM)(UF)]XXXXXXABABA[(TTX)]MXXXX.

#### 1.4.4 Certification

---

Audio Selector Panels and Amplifiers:	RTCA DO-170, Class II RTCA DO-160D
Airborne Radio Marker Receiver:	RTCA DO-143, Class A RTCA DO-138, DO-160D

## 1.5 Unit Nomenclature

---

Variants of the AMS50 series Stereo Audio Panel will be covered by manual supplements to be inserted in Section 8 (Supplements) of this manual, and are identified as follows:

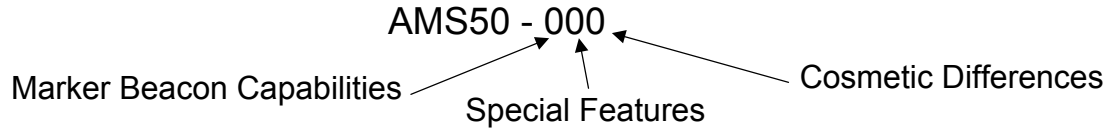

### 1.5.1 Marker Beacon

---

The digit in the first position of the unit suffix indicates the Marker Beacon Capabilities.

AMS50 - 000

<b>0</b>	=	Marker Beacon Capabilities
<b>1</b>	=	No Marker Beacon Capabilities

### 1.5.2 Special Features

---

The digit in the second position of the unit suffix indicates any special features installed.

AMS50 - 000

<b>0</b>	=	No Special Features
<b>Other</b>	=	Special Features (see relevant supplement for details.)

### 1.5.3 Cosmetic Differences

---

The digit in the third position of the unit suffix indicates Cosmetic Differences.

AMS50 - 000

<b>0</b>	=	Black faceplate with silver crown
<b>1</b>	=	Black faceplate with black crown
<b>Other</b>	=	Other cosmetic differences (see relevant supplement for details.)

End of section 1.0



## Section 2.0 Installation

### 2.1 Introduction

---

Information in this section consists of: unpacking and inspection procedures, installation procedures, post-installation checks, and installation drawings.

### 2.2 Unpacking and Inspection

---

Unpack the equipment carefully and locate the warranty card. Inspect the unit visually for damage due to shipping and report all such claims immediately to the carrier involved. Note that each unit should have the following:

- AMS50 Stereo Audio Panel
- Warranty Card
- Operator's Manual
- Release certification

Verify that all items are present before proceeding and report any shortage immediately to your supplier.

#### 2.2.1 Warranty

---

Complete the warranty card information and send it to NAT when the installation is complete. If you fail to complete the warranty card, the warranty will be activated on date of shipment from NAT.

**Note:** An appropriately rated facility, e.g. Certified Aircraft Repair Station, must install this equipment in accordance with applicable regulations. NAT Ltd's warranty is not valid unless the equipment is installed by an authorized NAT Dealer. Failure to follow any of the installation instructions, or installation by a non-certified individual or agency will void the warranty, and may result in a non-airworthy installation.

### 2.3 Installation Procedures

---

#### 2.3.1 Warnings

---

Do not bundle any lines from this unit with transmitter coax lines. Do not bundle any audio or DC power lines from this unit with 400 Hz synchro wiring or AC power lines. Do not position this unit or wiring from this unit next to any device with a strong alternating magnetic field such as an inverter, or significant audio interference will result.

### 2.3.2 Cautions

---

How and where grounds are tied together is very important in an audio panel installation. Twisted shielded paired wires shall be used for all audio lines from radios that have separate audio HI/LO connections. In all cases, the shield on these lines shall be grounded at both ends of the cable.

- ⇒ In all installations, use shielded cable exactly as shown and ground as indicated. Significant ground loop and noise problems may result from not following these guidelines.
- ⇒ Do not ground the microphone or headphone jacks.
- ⇒ Do not connect the microphone and headphone shields together.
- ⇒ Use caution when routing microphone wiring as it carries low level signals prone to coupling from other sources.
- ⇒ Do not take a ground from the instrument panel or similar location that shares a ground return with a turn and bank, horizon or other motor driven instrument. This may cause the unit to pick up the sound of the motor as ground loop interference.

### 2.3.3 Cabling and Wiring

---

All unshielded wire shall be selected in accordance with AC43.13-1B Change 1, Paragraphs 11-76 through 11-78. Wire types should be to MIL-W-22759 as specified in AC43.13-1B Change 1, Paragraphs 11-85, 11-86, and listed in Table 11-11. For shielded wire applications, use Tefzel MIL-C-27500 shielded wire with solder sleeves (for shield terminations) to make the most compact and easily terminated interconnect. Follow the wiring diagrams in Section 2.5 as required.

All wiring should be at least 22 AWG, except power and ground lines which should be at least 18 AWG. Ensure that all ground connections are clean and well secured.

To prevent system failure or inadequate equipment protection, supply power from a separate 3.0 Amp breaker not connected to any other source.

The AMS50 uses a special connector that mates directly with the printed circuit board inside the unit.

### 2.3.4 Accessories Supplied

An installation kit p/n AMS50-IKC (crimp) is provided to complete the installation. The kit consists of the following:

#### Crimp Kit

Quantity	Description	NAT Part #
4	M1 Screw, Panhead, Phillips, Steel, 4-40 x 5/8"	25-10-218
1	M2 Screw, Panhead, Phillips, Steel, 4-40 x 3/4"	25-10-219
1	M3 Bracket, Rear Support	50-06-003
2	M4 Card Edge 09-50-6225	20-66-044
85	M5 Contacts, Card Edge Crimp, #22-26 08-05-0303	20-26-006
6	M6 Contacts, Card Edge Crimp, #18-20 08-05-0301	20-26-005
2	M7 Polarizing Key, Card Edge Connectors	20-98-007
1	M8 Clamp and Strain Relief 3/16"	56-40-000
1	M9 Bracket, Angle	50-05-R139
1	M10 Chassis, Tray	50-02-049
4	M11 Washer, Locking, Split, 3mm	25-21-103
1	M12 Nut, Nylon Locking, Steel, Miniature	25-02-440M
1	M13 Washer, Flat, S/S #4	25-20-004

#### CONNECTOR VIEWS FROM FRONT OF TRAY

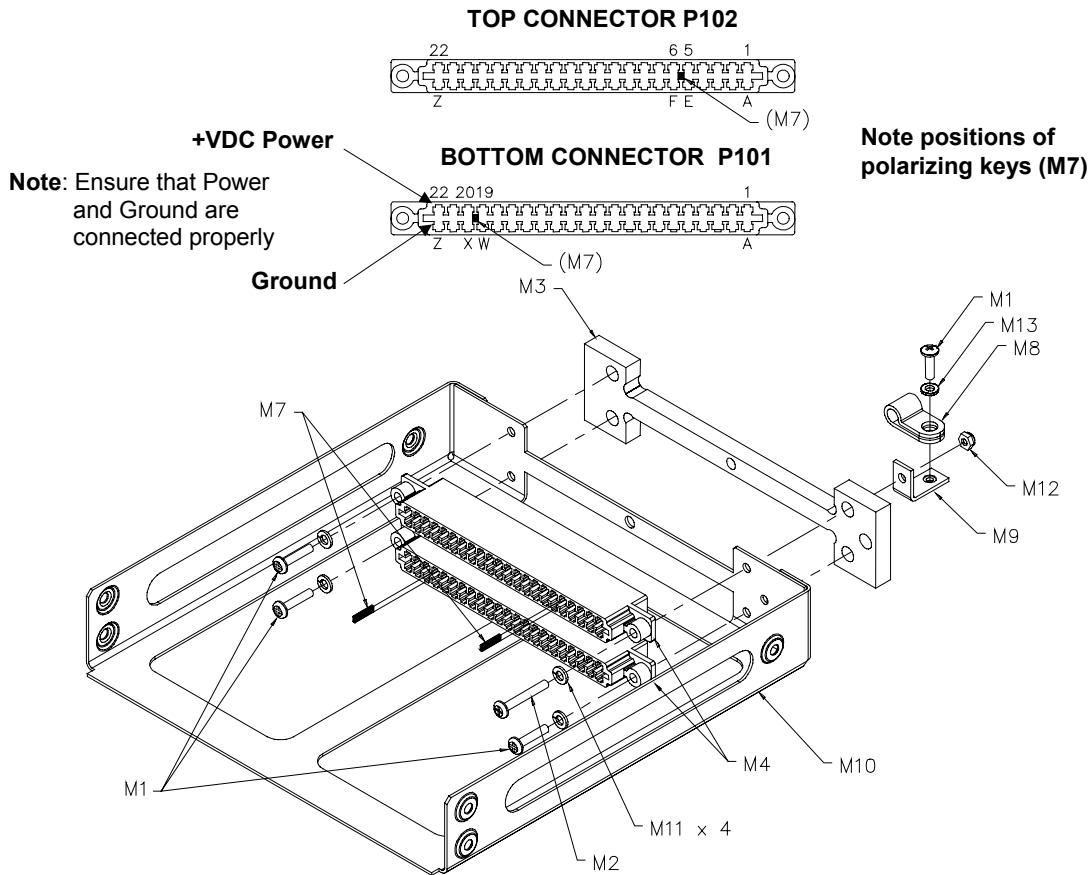

Fig. 1  
AMS50 Tray

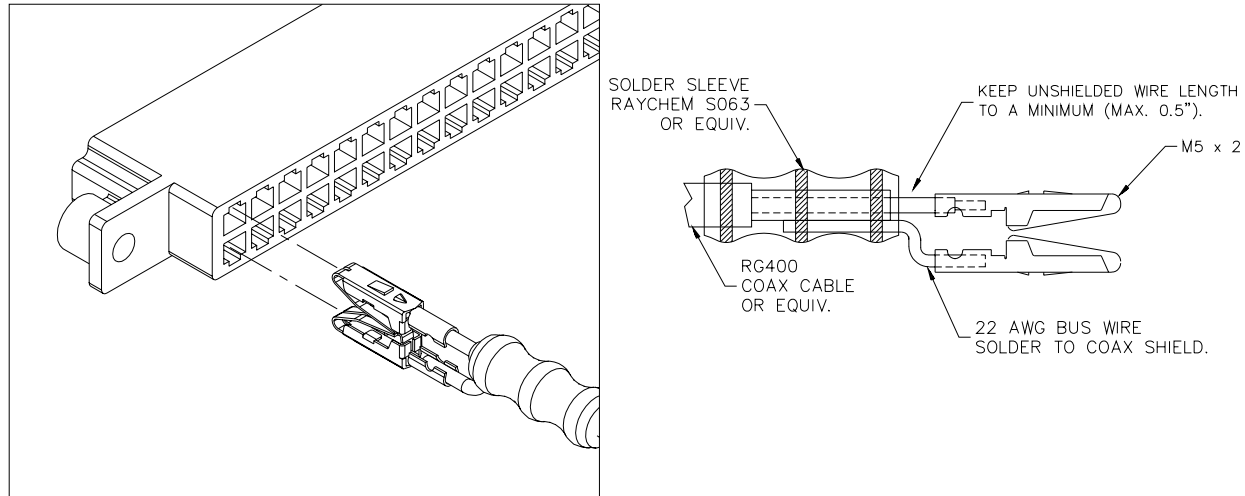

Fig. 2  
Marker Antenna Coax Connection

### 2.3.5 Mechanical Installation

2.3.5.1 The AMS50 may be mounted in any location with adequate area for the front panel and depth behind the panel for the unit, connector and wiring harness. Since the AMS50 is shorter than transceivers, the unit is generally mounted above the radio stack. In installations where the AMS50 is not supported by a radio stack, it is recommended that the rear of the tray is supported by brackets (not provided) to the airframe.

2.3.5.2 To mount the AMS50 tray, make a panel cutout using the dimensions shown in the **Mechanical Installation** drawing AMS50\000\922-0.

Note: The front lip of the mounting tray must be flush with the front edge of the instrument panel.

Mark, punch and drill the holes for the mounting rack using the dimensions on the **Mechanical Installation** drawing AMS50\000\922-0. Cross-check all hole positions with the mounting tray. Secure the mounting tray to the instrument panel using four (4) 6-32 hardware sets (flathead screws, washers and fibre nuts). Utilize support brackets on the rear of the tray if needed.

2.3.5.3 The AMS50 uses connectors that mate directly with the printed circuit board inside the unit. They are mounted to the tray using screws supplied in the install kit. Refer to the installation kit information in Section 2.3.4 for the correct hardware attachment.

Note: Ensure correct positioning of the card edge connectors (M4) and polarizing keys (M7) before installing to the AMS50 tray.

2.3.5.4. Slide the unit into the mounting tray until the locking rod contacts the rear of the mounting rack.

- 2.3.5.5 Insert a 3/32" Allen wrench through the hole in the front panel and turn clockwise until the unit is secure in the mounting tray. DO NOT OVERTIGHTEN.

Note: Manufacturing coatings may cause the locking rod to be a tight fit in the nut at the rear of the tray. Apply moderate force to overcome any resistance.

- 2.3.5.6 To remove the AMS50, turn the locking rod counterclockwise until the unit disengages from the mounting rack. If the unit is a tight mechanical fit, it may be necessary to pull the unit forwards as the locking rod is unscrewed.

## 2.3.6 Installation Options and Features

---

It is important to establish which options and features are required at the time of installation.

### 2.3.6.1 Telephone or Cell Phone Interlock (Field Selectable)

COM3 can be configured at installation as a telephone interlock. With the PHONE SEL pins (<12> and <N>) jumpered at connector P101, the keyline is automatically keyed with COM3 mic selection (i.e. there is no need for a separate PTT action). The mic is automatically connected to COM3 mic output, and in 'non-split' mode, both the Pilot's and Co-pilot's mics are active. If the ringer audio is provided on a separate line to the phone audio, consider using the AUX Rx input or a direct audio input.

If the telephone system that is being interfaced does not meet these specifications, an adapter is required i.e. AA34-300.

### 2.3.6.2 Option Select

The AMS50 is supplied with one external input (P101 pin <14>) to control firmware related functions. The AMS50-000 is configured to use this input for Music Mute defeat. When activated by a hard or switched ground, the music does not mute in the **CREW** and **ALL** mode, allowing both music and intercom simultaneously ('karaoke'). In **PLT ISO** the music is always muted for the Pilot only. When the remote switch is not activated, the normal muting scenarios are followed.

### 2.3.6.3 Stereo Music Installations

The AMS50 can accept stereo music input from portable entertainment units, CD players and other integrated on-board systems. Stereo output delivers high quality music to stereo aviation headsets or standard monaural general aviation headsets. Frequency response is 50 Hz to 15 kHz. Music muting occurs during all RX, TX, ATC or intercom activity, with a progressive return to the previous level. Music volume is controlled at the music source.

#### **CAUTION**

If monaural headsets are used, ensure that the outputs of the left and right channels are **not** connected together, and that only one channel is connected to the monaural phones jack.

### 2.3.6.4 Direct Audio Inputs

Accommodation is made for two (2) direct unswitched inputs (P101 pins <10>, <L>, <11> and <M>) for functions such as Rad Alt, telephone ringer audio, GPS alerts, etc. The direct inputs are not muted to the Pilot's headset.

### 2.3.6.5 Radio PTT Inputs

Separate PTT inputs are provided for the Pilot (P201 pin <10>) and Co-pilot (P201 pin <11>). Activation of a PTT input connects the user's microphone to the selected COM, and activates the output PTT to the selected COM.

When PTT is pressed, all audio (except the sidetone of the selected COM and direct audio inputs) is removed from the headphones of the particular PTT user, unless there is a telephone interconnect. All cockpit speaker audio is muted during radio PTT operations.

### 2.3.6.6 Pilot Remote TX Selection

Pilot selection of transmitters can also be made via a remote-mounted momentary switch, using P201 pins <L> and <M>.

### 2.3.6.7 Panel Lights

To set the AMS50 panel backlighting intensity to remain at maximum and not dim with the aircraft dimming buss, jumper the light power (P101 pin <20> or pin <21>) to the main dc power input of the AMS50 (P101 pin <22>).

### 2.3.7 Adjustments

---

See **Adjustment Hole Marks** drawing AMS50\000\908-0 at the end of this section of the manual for all adjustment locations.

The unit ships from the factory with all internal adjustments set to the normal test levels. Once installed in the aircraft, it may be desirable to change some of these settings to best suit the local operating environment.

<b>CAUTION</b>
----------------

Before performing the following adjustments ensure receive (radio) audio source is set to produce 2.5 Vrms  $\pm 10\%$  at the input to the AMS50, or the mute functions may not operate correctly.

#### 2.3.7.1 Music Mute

The music mute level sets the volume that the music will drop to during a music mute condition. There are separate level adjustments for the crew (**C MUSIC MUTE**) and passengers (**P MUSIC MUTE**).

To set the mute level, set the AMS50 to **ALL** mode and the **VOX** knob to live (fully ccw). Inject music and adjust the associated mute trim pot to set the desired level of muting (cw to increase and ccw to decrease). The fully ccw position gives a minimum muting of 30%. At 12 o'clock the muting level is 50% and at fully cw the muting level is 100% (music fully muted).

**Note:** In **CREW** mode, the crew's music level is automatically set to the muted level selected above.

### 2.3.7.2 MUSIC SOURCE Selection

The **MUSIC SOURCE** switch allows the user to input music from either a portable cassette/CD player (phone output) or CD changer/am/fm cassette player (line out). Select this switch to the right (**PTBL**) to accept music from the 'phone' output of a portable cassette/CD player. Select this switch to the left (**CHG**) to accept music from a CD changer/am/fm cassette player. When using a portable cassette/CD player, NAT recommends that the phone output is used for interface to increase tone control and volume. (The 'line out' output lacks volume and tone control.) Start with the volume about half way to confirm operation then adjust as desired.

#### CAUTION

Certain aircraft installations may use a car type, am/fm cassette or CD player with no 'line out' output. To use the 'speaker' outputs from the stereo unit, a floating ground adapter and input attenuation network (resistors) may be required to provide the correct system interconnect and to prevent damage to the music input(s) of the AMS50 and the speaker output circuits of the music source. Set the **MUSIC SOURCE** switch to the left (**CHG**).

### 2.3.7.3 Speaker output (SPKR)

The speaker audio is adjustable between 0-7 W into a 4  $\Omega$  load by rotating the **SPKR** pot on the rear of the unit.

#### CAUTION

The speaker is a bridged output. DO NOT ground either of the output leads. The speaker output does not need to be loaded if a speaker is not installed.

### 2.3.7.4 Backlighting and Indicator Intensity Adjustments

The intensity of the backlighting (**BACK LIGHT**) and indicators (**IND**) can be adjusted to match neighbouring avionics by rotating the respective pots on the bottom of the unit.

### 2.3.7.5 Marker adjustments.

The **MKR HI**, **MKR LO** and **MKR LEVEL** switches should only be used in conjunction with the **Acceptance Test Procedure** AMS50\614-0 found in the Maintenance Section (Section 5) of this manual.

## 2.3.8 Post-Installation Checks

---

### 2.3.8.1 Voltage/resistance checks

**Do not attach the AMS50 until the following conditions are met.**

Check the following:

- a) Check P101, pin <20> for dimmer buss voltage relative to ground (28 V installations).
- b) Check P101, pin <21> for dimmer buss voltage relative to ground (14 V installations).
- c) Check P101, pin <22> for +11 to 33 Vdc relative to ground.
- d) Check P101, pins <X> and <Z> for continuity to ground (less than 0.5  $\Omega$ ).
- e) Check P201, pins <L> and <M> for continuity to ground (less than 0.5  $\Omega$ ) with the remote select switch activated to the relevant position.

### 2.3.8.2 Power On checks

Install the AMS50 and power up the aircraft's systems. Verify normal operation of all functions. Refer to Section 3 (Operation) for specific operational details.

- a) Begin with only the Pilot's headset installed, no hand mic. Check for correct radio operation, both receive and transmit. Check yoke (or cyclic) switch action. Check radio audio inputs and selection of same.
- b) If there is a music source in the system turn it on and verify that music is muted in the **CREW** mode and removed in the **PLT ISO** mode. Check for proper mute operation.

Note: Unusual buzzes, hums or other background audio are symptomatic of multiple grounds, or noisy external systems such as blowers or pumps sharing wiring with the audio system. Failure to key or correctly modulate a transmitter is often the result of forgetting to connect all required grounds to the radio or external audio system.

- c) Check the ICS Modes (**ALL**, **CREW**, **PLT ISO**), and the **SPLIT** transmit selection and manual Fail-safe operation.
- d) Plug in the Co-pilot's headset. Check for correct ICS and **SPLIT** transmit operation. Check that the Co-pilot loses transmit capability during **PLT ISO**. Check yoke switch functions.
- e) Plug in the hand mic, if installed, and test for correct operation in all modes.
- f) Plug in any remaining headsets, and check for correct ICS operation.

**Note:** Incorrect jack wiring is a common fault for rear passenger stations, and may cause a wide range of problems.

- g) Using the appropriate ramp test equipment, test the Marker Receiver for correct operation (lights and audio).
- h) To verify proper operation, all functions and levels should be checked in-flight.

**Upon satisfactory completion of all performance checks, make the required log entries and complete the necessary Regulatory Agency paperwork before releasing the aircraft for service.**

## **2.4 Continued Airworthiness**

Maintenance of the AMS50 is 'on condition' only. Periodic maintenance of this product is not required.

## **2.5 Installation Drawings**

<b>DRAWING</b>	<b>REV.</b>	<b>DESCRIPTION</b>	<b>TYPE</b>	<b>SERIAL #</b>
AMS50\000\403-0	1.00	Stereo Audio Panel with Marker	Interconnect	All
AMS50\000\403-1	1.00	Stereo Audio Panel with Marker	Interconnect	All
AMS50\000\403-2	1.00	Stereo Audio Panel with Marker	Interconnect	All
AMS50\000\405-0	1.00	Stereo Audio Panel with Marker	Connector Map	All
AMS50\000\521-0	1.00	Stereo Audio Panel with Marker	Environmental Qual Form	2000 and up
AMS50\000\905-0	1.00	Stereo Audio Panel with Marker	Faceplate	All
AMS50\000\908-0	1.00	Stereo Audio Panel with Marker	Adjustment Hole Marks	All
AMS50\000\922-0	1.00	Stereo Audio Panel with Marker	Mechanical Installation	All

Section 2.0 ends after these Drawings

AMS50 INSTALLATION NOTES

NOTES:

- ① ALL WIRES SHOULD BE 22 AWG UNLESS OTHERWISE SPECIFIED. ALL WIRE SHOULD BE IN ACCORDANCE WITH MIL-W-22759. ALL SHIELDED WIRE/CABLE SHOULD BE IN ACCORDANCE WITH MIL-C-27500.
- ② PARALLEL CONNECTIONS FOR ADDITIONAL PAX HEADPHONES (MAX 4).
- ③ DO NOT GROUND MICROPHONE OR HEADPHONE LO CONNECTIONS TO AIRFRAME. MIC AND PHONE JACKS SHOULD BE ISOLATED FROM AIRFRAME.
- ④ IF AIRCRAFT ENTERTAINMENT SYSTEM (MUSIC) HAS BALANCED SPEAKER OUTPUTS, A FLOATING GROUND ADAPTER BETWEEN THE AUDIO PANEL AND THE ENTERTAINMENT SYSTEM WILL BE REQUIRED.
- ⑤ CHASSIS GROUND LEAD LESS THAN 1m LENGTH.
- ⑥ FIXED LEVEL DIRECT AUDIO INPUT. NO ADJUSTMENT.
- ⑦ BRIDGED OUTPUT. DO NOT GROUND EITHER SPEAKER WIRE.
- ⑧ INSTALL PHN SEL JUMPER TO ACTIVATE TELEPHONE OPTION. REFER TO INSTALL MANUAL FOR DETAILS. CONNECT AS SHOWN ONLY WITH A TELEPHONE INSTALLATION.
- ⑨ LIGHT POWER MAY BE CONNECTED TO MAIN POWER IF THE USER DOES NOT WANT BACKLIGHTING TO DIM WITH THE AIRCRAFT DIMMING BUS.
- ⑩ O/P ACTIVE HI (4.5VDC @ 200uA)
- ⑪ MARKER BEACON ANTENNA. COMANT P/N CI102 OR EQUIVALENT.
- ⑫ PROVIDE LAMP VOLTAGE SOURCE AS PER LAMP RATING. MAX CURRENT PER LINE IS 125 mA.
- ⑬ SEE NAT SERVICE MANUAL SM50 SECTION 2 FOR INSTALLATION OPTIONS.

DEFINITIONS:

N/C: NO CONNECTION. THE PIN IS NOT CONNECTED TO ANYTHING INTERNALLY, AND THEREFORE SHALL HAVE NO CONNECTION EXTERNALLY.

RESERVED: MAY BE CONNECTED AND USED IN THE FUTURE. THE CIRCUITRY MAY BE PRESENT OR ADDED TO ACTIVATE THE FUNCTION. THE PIN MAY BE USED FOR TEST PURPOSES. THERE IS NO EXTERNAL CONNECTION.

PROPRIETARY AND CONFIDENTIAL TO NAT LTD.

DESIGNED	TAB	<b>NAT</b> NORTHERN AIRBORNE TECHNOLOGY LTD.				
DRAWN	MWS					
DATE	MAY 28/01	TITLE STEREO AUDIO PANEL WITH MARKER				
CHECKED	NAT 114 223					
APPROVED	NAT 107	SIZE	CAGE CODE	PART NO.	REV.	SHEET
FILE	403-0100.DWG	A	3AB01	AMS50-0xx	1.00	1/3
		DWG. TYPE	INTERCONNECT	DWG. NO. AMS50\000\403-0		



AMS50

J101

P101  
44 PIN FEMALE EDGE  
MATING CONNECTOR  
BOTTOM CONNECTOR

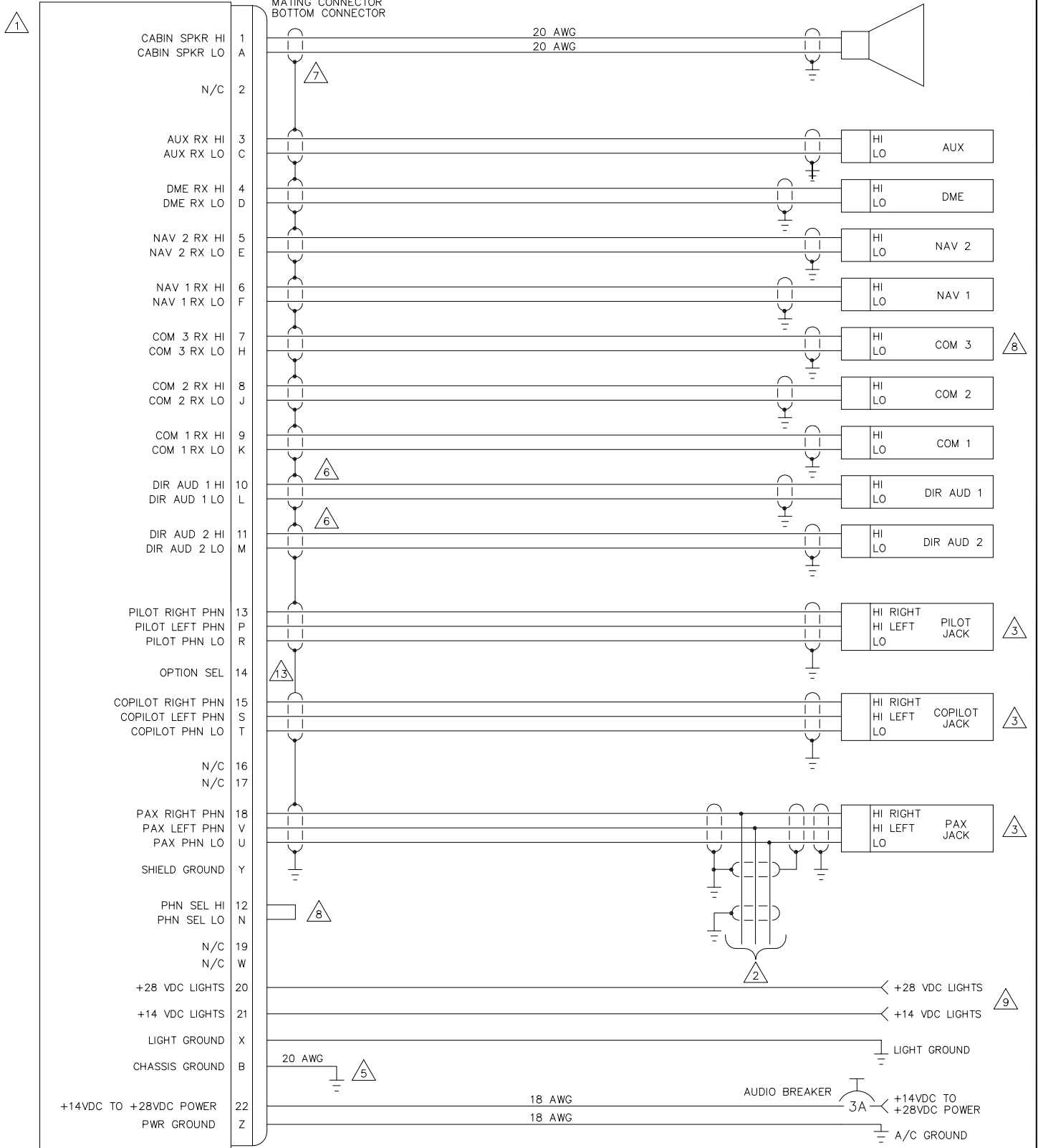

PROPRIETARY AND CONFIDENTIAL TO NAT LTD.

DESIGNED	TAB	<b>NAT</b> NORTHERN AIRBORNE TECHNOLOGY LTD.				
DRAWN	MWS					
DATE	MAY 28/01	TITLE STEREO AUDIO PANEL WITH MARKER				
CHECKED						
APPROVED		SIZE	CAGE CODE	PART NO.	REV.	SHEET
FILE	403-0100.DWG	A	3AB01	AMS50-0xx	1.00	2/3
DWG. TYPE		INTERCONNECT		DWG. NO. AMS50\000\403-1		



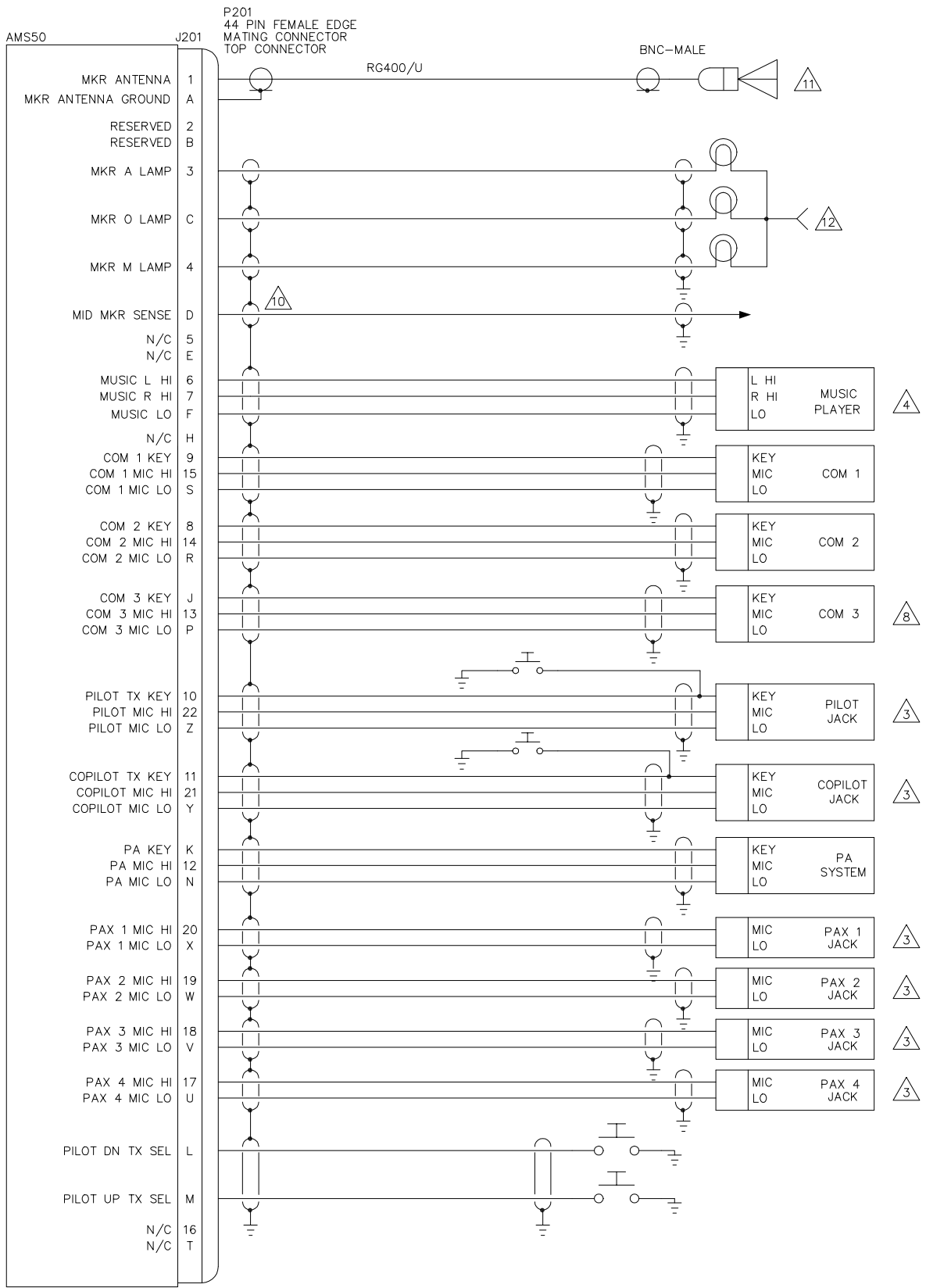

PROPRIETARY AND CONFIDENTIAL TO NAT LTD.

DESIGNED	TAB	 <b>NAT</b> NORTHERN AIRBORNE TECHNOLOGY LTD.				
DRAWN	MWS					
DATE	MAY 28/01	TITLE				
CHECKED	<b>NAT 114</b> <b>NAT 223</b>	STEREO AUDIO PANEL WITH MARKER				
APPROVED	<b>NAT 107</b>	SIZE	CAGE CODE	PART NO.	REV.	SHEET
FILE	403-0100.DWG	A	3AB01	AMS50-0xx	1.00	3/3
DWG. TYPE		INTERCONNECT		DWG. NO. AMS50\000\403-2		



P201

44 PIN FEMALE EDGE  
MATING CONNECTOR  
TOP CONNECTOR

MKR ANTENNA	RESERVED	MKR LAMP	MKR LAMP	N/C	MUSIC HI	MUSIC HI	COM 2 KEY	COM 1 KEY	PILOT TX KEY	COPILOT TX KEY	PAMIC HI	COM 3 MIC HI	COM 2 MIC HI	COM 1 MIC HI	N/C	PAX 4 MIC HI	PAX 3 MIC HI	PAX 2 MIC HI	PAX 1 MIC HI	COPILOT MIC HI	PILOT MIC HI
1	2	3	4	5	6	7	8	9	10	11	12	13	14	15	16	17	18	19	20	21	22
A	B	C	D	E	F	H	J	K	L	M	N	P	R	S	T	U	V	W	X	Y	Z
MKR ANTENNA GROUND	RESERVED	MKR O LAMP	MID MKR SENSE	N/C	MUSIC LO	N/C	COM 3 KEY	PAX KEY	PILOT DN TX SEL	PILOT UP TX SEL	PAMIC LO	COM 3 MIC LO	COM 2 MIC LO	COM 1 MIC LO	N/C	PAX 4 MIC LO	PAX 3 MIC LO	PAX 2 MIC LO	PAX 1 MIC LO	COPILOT MIC LO	PILOT MIC LO



P101

44 PIN FEMALE EDGE  
MATING CONNECTOR  
BOTTOM CONNECTOR

CABIN SPKR HI	N/C	AUX RX HI	DME RX HI	NAV 2 RX HI	NAV 1 RX HI	COM 3 RX HI	COM 2 RX HI	COM 1 RX HI	DIR AUD 1 HI	DIR AUD 2 HI	PHN SEL HI	PILOT RIGHT PHN	OPTION SEL	COPILOT RIGHT PHN	N/C	N/C	PAX RIGHT PHN	N/C	+28 VDC LIGHTS	+14 VDC LIGHTS	+14 VDC TO +28VDC POWER
1	2	3	4	5	6	7	8	9	10	11	12	13	14	15	16	17	18	19	20	21	22
A	B	C	D	E	F	H	J	K	L	M	N	P	R	S	T	U	V	W	X	Y	Z
CABIN SPKR LO	CHASSIS GROUND	AUX RX LO	DME RX LO	NAV 2 RX LO	NAV 1 RX LO	COM 3 RX LO	COM 2 RX LO	COM 1 RX LO	DIR AUD 1 LO	DIR AUD 2 LO	PHN SEL LO	PILOT LEFT PHN	PILOT PHN LO	COPILOT LEFT PHN	COPILOT PHN LO	PAX PHN LO	PAX LEFT PHN	N/C	LIGHT GROUND	SHIELD GROUND	PWR GROUND

VIEW IS FROM REAR OF AIRFRAME CONNECTOR

PROPRIETARY AND CONFIDENTIAL TO NAT LTD.

DESIGNED	TAB	 <b>NAT</b> NORTHERN AIRBORNE TECHNOLOGY LTD.				
DRAWN	MWS					
DATE	MAY 07/01	TITLE				
CHECKED		STEREO AUDIO PANEL WITH MARKER				
APPROVED		SIZE	CAGE CODE	PART NO.	REV.	SHEET
FILE	405-0100.DWG	A	3AB01	AMS50-0xx	1.00	1/1
DWG. TYPE		CONNECTOR MAP			DWG. NO. AMS50\000\405-0	





# ENVIRONMENTAL QUALIFICATION FORM

Description: Stereo Audio Panel with Marker Document #: AMS50\000\521-0

NAT Part #: AMS50-0XX TSO #: C50c, C35d

Manufacturer's Specification and/or Other Applicable Specification: \_\_\_\_\_

**RTCA: DO-160D, DO-138**

Manufacturer: Northern Airborne Technology Ltd.

Address: #14 - 1925 Kirschner Rd., Kelowna, BC, Canada. V1Y 4N7

Prepared By:



Checked By:

NAT  
208



Approved By:



Conditions	DO-160D Section	Description of Conducted Tests
Temperature and Altitude	4.0	Equipment tested to Categories A1, D1
Low Temperature High Temperature	4.5.1 4.5.2 & 4.5.3	-20C Operating Low Temperature +55C Operating High temperature +70C Short-term Operating High Temperature
Altitude Decompression Overpressure	4.6.1 4.6.2 4.6.3	Maximum Operating Altitude 50,000 ft.
Temperature Variation	5.0	Equipment tested to Category B
Humidity	6.0	Equipment tested to Category A
Shock	7.0	Equipment tested to Category B
Operational Crash Safety	7.2 7.3	Test Procedure 1 (Impulse) Test Procedure 2 (Sustained)
Vibration	8.0	Equipment tested to categories SBM, UF
Explosion	9.0	Equipment identified as Category X no test required
Waterproofness	10.0	Equipment identified as Category X no test required

Rev: 1.00

Dec 6, 2001

Page 1 of 3

ENG-FORM: 521-0102.DOT

**CONFIDENTIAL AND PROPRIETARY TO NORTHERN AIRBORNE TECHNOLOGY LTD.**

<b>Conditions</b>	<b>DO-160D Section</b>	<b>Description of Conducted Tests</b>
Fluids Susceptibility	11.0	Equipment identified as Category X no test required
Sand and Dust	12.0	Equipment identified as Category X no test required
Fungus	13.0	Equipment identified as Category X no test required
Salt Spray	14.0	Equipment identified as Category X no test required
Magnetic Effect	15.0	Equipment is Class Z
Power input	16.0	Equipment tested to Category B Equipment was tested to subparagraph 16.5.1.4 b, requirement for equipment with digital circuits. Equipment was not tested to Emergency Operating Voltages. Abnormal Surge Voltage, subparagraph 16.5.4, for 28V operation tested to 60 Vdc for 100 ms and 37.8 Vdc for 1 second.
Voltage Spike	17.0	Equipment tested to Category A
Audio Frequency Susceptibility	18.0	Equipment tested to Category B
Induced Signal Susceptibility	19.0	Equipment tested to Category A
Radio Frequency Susceptibility	20.0	Equipment tested to Category TTX
Radio Frequency Emission	21.0	Equipment tested to Category M
Lightning Induced Transient Susceptibility	22.0	Equipment identified as Category X no test required
Lightning Direct Effects test	23.0	Equipment identified as Category X no test required



Conditions	DO-160D Section	Description of Conducted Tests
Icing	24.0	Equipment identified as Category X no test required
Electrostatic Discharge (ESD)	25.0	Equipment identified as Category X no test required

Conditions	DO-138 Section	Description of Conducted Tests
RF Susceptibility	13.0	Marker Receiver tested to Category Z

**REMARKS**

- Tests were conducted at Northern Airborne Technology Ltd.

End of Environmental Qualification Form



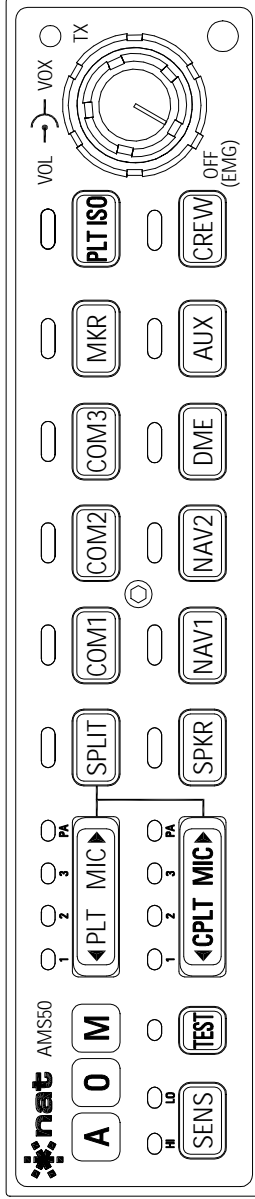

PROPRIETARY AND CONFIDENTIAL TO NAT LTD.

DESIGNED	TAB	<b>nat</b> NORTHERN AIRBORNE TECHNOLOGY LTD.	
DRAWN	MWS		
DATE	APR 25/01	TITLE	
CHECKED	NAT 208	SIZE	STEREO AUDIO PANEL WITH MARKER
APPROVED	NAT 107	CAGE CODE	REV. SHEET
FILE	905-0100.DWG	PART NO.	AMS50-0xx
		DWG. TYPE	1.00 1/1
		FACEPLATE	DWG. NO. AMS50\000\905-0







REVISIONS			
REV	DESCRIPTION	DATE	BY
1.01	ECR #2152 - REMOVED LABEL TEXT, CHANGED ALL OUTSIDE DIMENSIONS TO MAX, ADDED POS'N TOLERANCE TO MTG HOLES, FORMAT CHANGES.	FEB 07/02	MWS

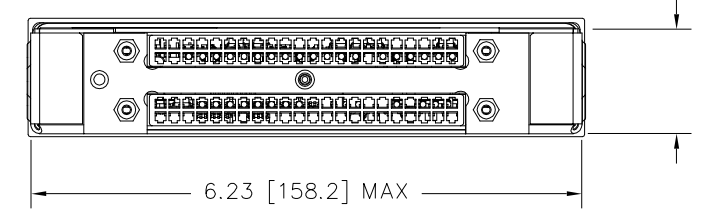
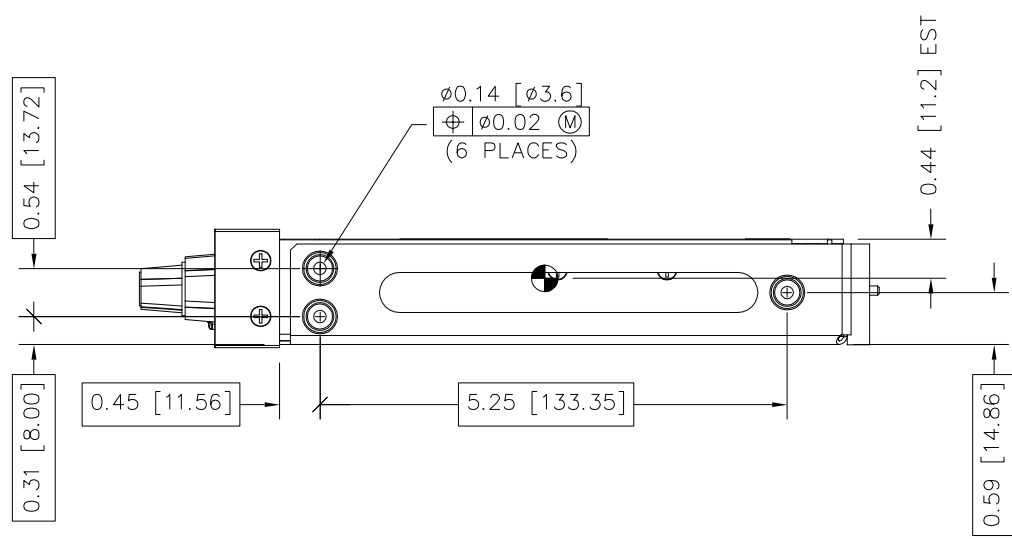
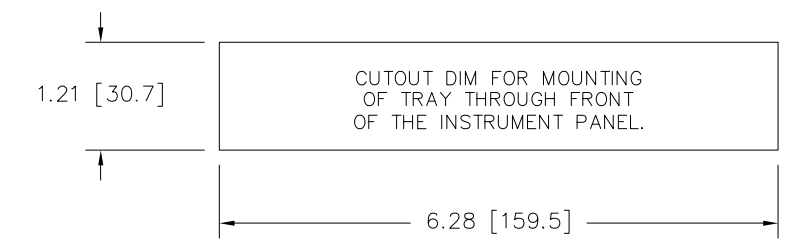
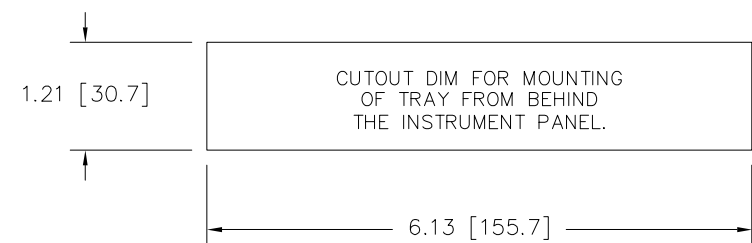
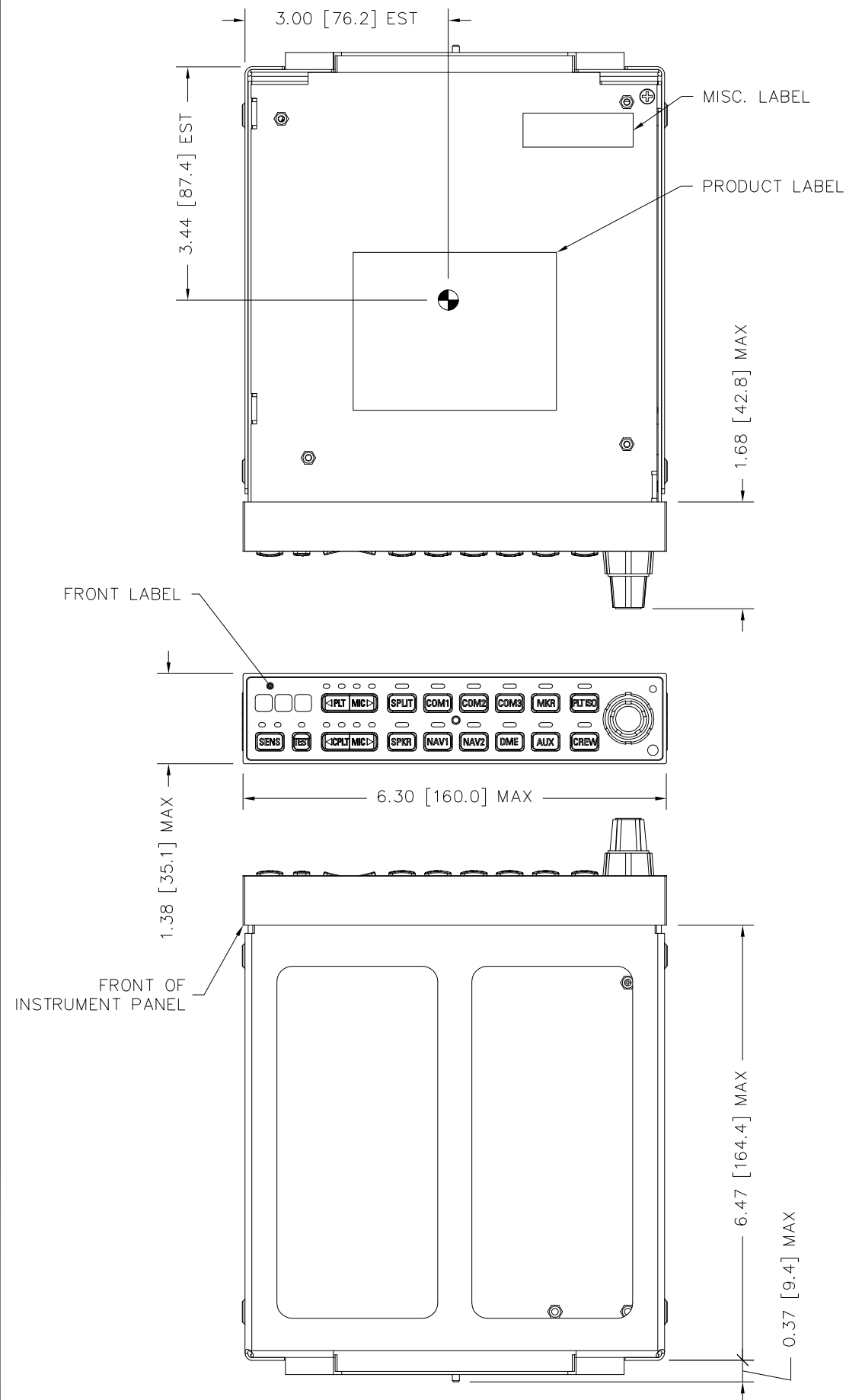

NOTES:  
1. DIMENSIONING AND TOLERANCING IN ACCORDANCE WITH ASME Y14.5M-1994

● CENTER OF GRAVITY

CONFIDENTIAL AND PROPRIETARY TO NAT LTD.

DIMENSIONS ARE INCHES [mm]	DESIGNED DRAWN	TAB MWS	<b>nat</b> NORTHERN AIRBORNE TECHNOLOGY LTD.				
THIRD ANGLE PROJECTION	DATE	MAY 03/01	TITLE STEREO AUDIO PANEL WITH MARKER				
MASS: 2.2 lbs. (1 kg) MAX	CHECKED	NAT 208	NAT 223	NAT 114			
MATERIAL -	APPROVED	NAT 107	SIZE B	CAGE CODE 3AB01	PART NO. AMS50-0xx	REV. 1.01	SHEET 1/1
FINISH CHROMATE CONVERSION	FILE	922-010T.DWG	DWG. TYPE	MECH. INSTALLATION	DWG. NO.	AMS50\000\922-0	



## Section 3.0 Operation

### 3.1 Introduction

Information in this section consists of the functional and operational procedures for the AMS50 Stereo Audio Panel.

### 3.2 Controls and Indicators

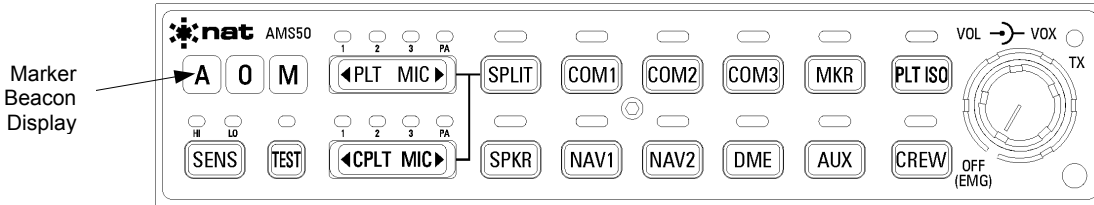

The front panel controls consist of a concentric VOL/VOX knob, and two banks of tactile push-button switches with amber backlighting. When selected, the operator will feel the switch operate, and the associated LED will illuminate. The function indicator LEDs and Marker Beacon lights feature self-contained photocell dimming (no operator action required), and the backlighting of the push-buttons is controlled with the aircraft dimming.

The functions of the controls will be considered separately in sections 3.2.1 to 3.2.8 below. The associated indicators will be discussed in the relevant sections.

#### 3.2.1 Transmit Operation

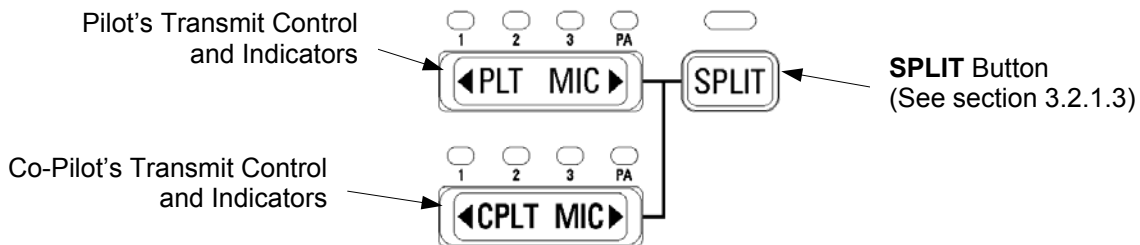

There are two isolated PTT inputs for the Pilot and Co-pilot. Activation of the PTT inputs connects the user's MIC to the selected COM, and activates the output PTT to the selected COM.

When either PTT is pressed, the music and all ICS audio is muted from the headphone of the particular PTT user. The following audio is NOT muted during PTT: the sidetone of the selected Transmitter, the Receive selections (COMs, NAVs, MKR, DME or AUX) and the Direct Audios.

All cockpit speaker audio is muted by either PTT input.

### 3.2.1.1 Transmit Functions

The **TRANSMIT** functions are controlled from two transmitter select rocker push-buttons (**PLT MIC** and **CPLT MIC**). Each rocker has the capability to select only one transmitter at a time, i.e. **1** (COM 1), **2** (COM 2), **3** (COM 3), or **PA**. The relevant green LED above the switch will illuminate to indicate the selected transmitter. Pressing the right (▶) side of the button will select the option one place to the right of the current selection, and pressing the left (◀) side will move the selection one place to the left. The selection options will wrap around – i.e. one step to the right from the PA option will select COM 1, and one step to the left of COM 1 will move the selection to PA. The Receive audio from the selected COM is automatically present. See also section 3.2.1.3 – **SPLIT** Button.

### 3.2.1.2 PA Function

The PA position provides a mic and PTT output selection to an external amplifier for use as either a loudhailer or Passenger Address system.

### 3.2.1.3 SPLIT Button

The **SPLIT** function button separates or combines the control of the TX selection buttons. When the **SPLIT** function is active, the LED above the switch will illuminate green, and each transmit select button will operate independent of the other to allow different radios to be selected simultaneously. When the **SPLIT** function is not active, the LED will remain dark, and operation of either of the two Transmit select buttons will move the Pilot's and Co-pilot's selection simultaneously. When the **SPLIT** function is changed from 'active' to 'inactive', the Co-pilot's current selection will change to match the Pilot's. The LEDs above the COM Receiver Audio push-buttons do not illuminate unless they are specifically selected. Each Pilot will only hear the audio from the transmitter they have selected unless any COM Receive Audio push-button is also engaged. Pilot selection of the transmitters can also be made via an optional remote mounted momentary switch.

## 3.2.2 Receive Functions

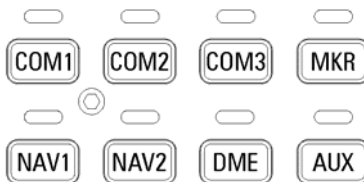

The three COM receiver audio push-buttons (**COM1**, **COM2** and **COM3**), and five NAV receiver audio push-buttons (**MKR**, **NAV1**, **NAV2**, **DME** and **AUX**) are used for monitoring COM or NAV radio audio.

When a push-button is selected, the green LED above it will illuminate to indicate that the input is 'on'. Both Pilots hear all selected audio, except in **PLT ISO** mode (see section 3.2.3.2). Passengers hear all selected audio in **ALL** mode only (see section 3.2.3.3).

**Note:** When a transmitter is selected (see section 3.2.1.1) the Receive audio from the selected COM is automatically present.

### 3.2.3 ICS Functions

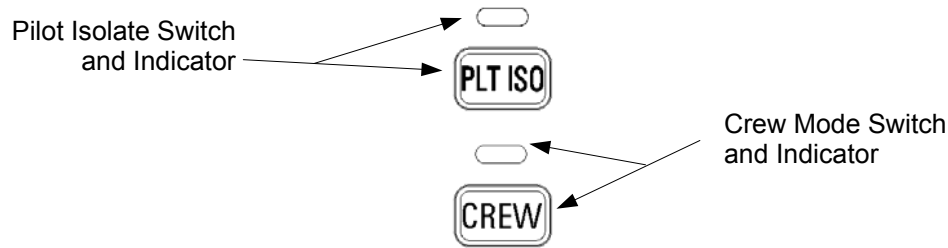

The AMS50 features three operating modes as outlined below. Intercom (ICS) and music audio will have different muting features depending on the selected ICS mode (see section 3.2.3.4). Selection of a specific mode will cause the related LED to illuminate. To deselect, either press the same button again (the LED will go dark) or press the alternate selection (the LED for the newly selected mode will illuminate, and the previous LED will go dark).

#### 3.2.3.1 CREW Mode

When the **CREW** button is pressed, the green LED above it will illuminate to indicate that the ICS system is in **CREW** mode.

The Pilot and Co-pilot are isolated from the passengers but retain normal radio operations. The crew and passengers each retain full intercom capabilities within their own groups, but the passengers are prevented from hearing any radio communications while still retaining normal music muting. The crew's music level is automatically set to the mute level selected at installation.

#### 3.2.3.2 PLT ISO Pilot Isolate Mode

When the **PLT ISO** button is pressed, the green LED above it will illuminate to indicate that the intercom system is in Pilot Isolate mode.

In this mode, the Pilot is separated from the intercom network, allowing confidential radio communications without interference from the passenger intercom or music. While in **PLT ISO** mode, the Pilot maintains complete control of all the radio functions of the audio panel. The Co-pilot is connected with the passengers, and is removed from all radio operations.

#### 3.2.3.3 All Mode

If neither the **CREW** nor **PLT ISO** buttons is pressed, both the indicator LEDs will remain dark, signifying that the system is in the ALL (default) mode.

This mode permits everyone on the system to talk to each other, listen to music, and hear all radio communications.

**3.2.3.4 Music and ICS Muting**

The mute level is adjusted during installation. The tables below show the muting effects in each mode.

EFFECT ⇨	Effect on Crew Music				Effect on PAX Music		
	All Mode	Crew Mode	PLT ISO		All Mode	Crew Mode	PLT ISO
PIL TX Key	Mute	N/A  (already muted)	N/A  (already muted)		Mute	No Mute	No Mute
COP TX Key	Mute				Mute	No Mute	N/A
RX Detect	Mute				Mute	No Mute	No Mute
PAX ICS	Mute				Mute	Mute	Mute
Pilot ICS	Mute				Mute	No Mute	N/A
Co-pilot ICS	Mute				Mute	No Mute	Mute

N/A= Not Affected by this action.

EFFECT ⇨	Effect on Crew ICS				Effect on PAX ICS		
	All Mode	Crew Mode	PLT ISO		All Mode	Crew Mode	PLT ISO
PIL TX Key	*Mute	*Mute	N/A		*Mute	No Mute	N/A
COP TX Key	*Mute	*Mute	N/A		*Mute	No Mute	N/A

\* ICS is not muted during PA Tx to provide artificial sidetone. N/A= Not Affected by this action.

**Note:** In **PLT ISO** mode the Crew consists of the Pilot only. The Co-pilot is considered to be a passenger.

**3.2.3.5 Radio Audio Muting**

The Pilot Radio audio is never muted. To mute the COM and NAV RX audios, they must be de-selected. These audios are muted to the PAX in both CREW and PLT ISO modes.

**3.2.4 Speaker and Test Buttons**

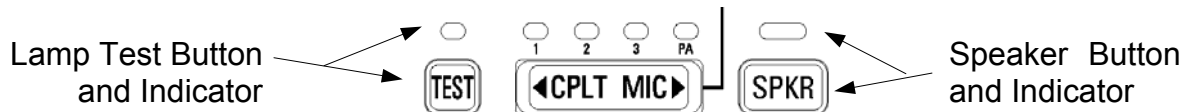

**3.2.4.1 SPKR (Speaker Button)**

Radio audio can be switched to a cockpit speaker via the **SPKR** push-button. Turning on the cockpit speaker will have no effect on headset audio. Only the direct audio and audio from the Receive selections (**not** intercom, music, or transmit selection audio) is available to the speaker. A green LED above the push-button is illuminated to indicate that the speaker is on. Headset audio always remains on and can not be deselected.

**3.2.4.2 TEST (Lamp Test Button)**

This button enables the operator to confirm correct operation of all the front panel indicator LEDs. The LEDs will illuminate for as long as the button is pressed in.

**Note:** The audio from the marker beacon receiver is not tested by this button.

### 3.2.5 ICS and VOX Volume Control

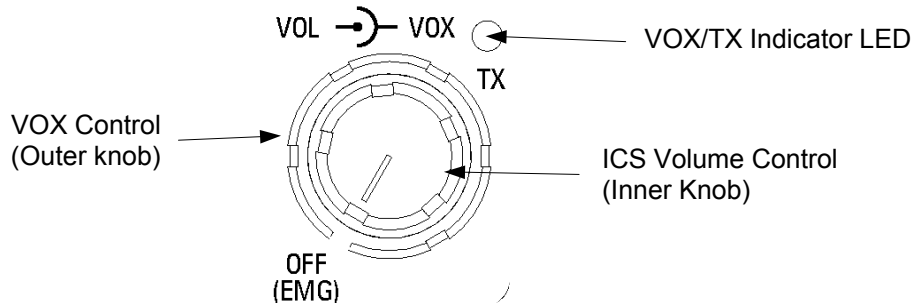

The **ICS** and **VOX** volume controls for the Crew and Passenger groups consists of a concentric control knob – the inner knob controls the ICS volume, and the outer knob controls the sensitivity of the VOX circuit. Turning the **ICS** volume knob completely counter-clockwise (ccw) to the detent will switch the unit to manual fail-safe mode. (See section 3.2.5.3.)

#### 3.2.5.1 VOX Control

The **VOX** control is used to adjust the voice level that is required to activate the mic and pass the audio to the headsets. Rotating the control clockwise (cw) decreases the sensitivity of the circuit, and ccw increases it until in the fully ccw position, all the mics are live. The **VOX** squelch can be set as described in section 3.2.5.2.

#### 3.2.5.2 VOX/TX Indicator LED

The VOX/TX indicator is a bicolor LED located in the upper right corner of the panel. The LED will illuminate amber to indicate any transmit activity, and will illuminate green to indicate that one of the six VOX squelch circuits has been triggered. The TX LED (amber) always overrides the VOX LED (green).

#### TX Indication

The LED will illuminate amber to indicate any transmit activity (when a radio PTT has been triggered), and will also indicate a stuck Mic (PTT) if it remains lit after transmission is concluded. The amber LED is only on during Pilot or Co-pilot TX Key in **ALL** and **CREW** mode, and only on for the Pilot TX Key in **PLT ISO** mode. The TX LED does not illuminate at any time when COM3 is selected in a 'telephone' installation.

#### VOX Indication

The LED will illuminate green to indicate that one of the six VOX squelch circuits has been triggered. It can be used to set the VOX threshold by turning the VOX control knob ccw until the LED turns green, and then rotating the control cw until the LED goes dark. Continue turning the knob cw until the desired voice sensitivity is reached.

The table below shows how the illumination of the LED varies in each ICS mode.

	VOX LED (Green)		
	All Mode	Crew Mode	Pilot ISO
PAX ICS	On	Off	On
Pilot ICS	On	On	Off
Co-pilot ICS	On	On	On

### 3.2.5.3 Manual Fail-safe

Manual fail-safe operation is available in the event of a partial failure (for example headset amp failure or any suspected abnormal operation). To 'reset' the unit, turn the ICS volume control to the **OFF(EMG)** position (turned ccw until it clicks), and then back **ON**. If left in the **OFF(EMG)** position, it will route the Pilot directly to the COM1 radio and the unswitched direct audio inputs, and turn the system off for the Co-pilot and Passengers.

#### CAUTION

If the emergency voltage of the aircraft falls below 11 Vdc, the unit must be run in the Manual Fail-safe mode to ensure correct operation.

### 3.2.6 Marker Beacon

The AMS50 contains a built-in Marker Beacon receiver with a three light display. The white light marked '**A**' will illuminate when the signal from the 'Airways' (or 'Inner') beacon is received; the blue light marked '**O**' will illuminate at the 'Outer' beacon; and the amber light marked '**M**' will illuminate at the 'Middle' beacon.

#### 3.2.6.1 Sensitivity Button (**SENS**)

The switch below the 'A' light is used to select between '**HI**' and '**LO**' for the 'en route' and 'approach' sensitivity of the Marker Beacon receiver. Either the **HI** or **LO** LED above the switch will illuminate green to indicate the current selection.

### 3.2.7 Automatic Fail-safe

Automatic fail-safe operation is a standard feature in the event of a power failure. The Pilot is routed directly to COM1 and the unswitched direct audio inputs. The system is off for the Co-pilot and Passengers.

### **3.2.8 Optional Features**

---

#### **3.2.8.1 Telephone Interlock**

At installation, COM3 can be configured as a telephone interlock for full duplex operation. Selecting the COM3 RX Select switch provides the ability to monitor phone ringer audio or conversation. If the ringer audio is separate from the phone audio, it should be connected to one of the direct audio inputs.

To answer the phone or make a call, choose the COM3 TX selection. This causes the respective (selected) crew's microphone to become 'hot' when selected from the front panel with no need for the operator to activate the PTT switch. The COM3 input can only be a COM radio or a Telephone, but not both in the same installation.

In 'non-split' mode, both the Pilot's and Co-pilot's mics are active.

#### **3.2.8.1 Karaoke**

The AMS50-000 may be configured at the time of installation to allow Music Mute defeat. When activated by a hard or switched ground, the music does not mute in the CREW and ALL mode, allowing both music and intercom simultaneously ('karaoke'). In PLT ISO the music is always muted for the Pilot only. When the remote switch is not activated, the normal muting scenarios are followed.

### **3.3 Start-Up Selections**

---

At power-up, the AMS50 will default to the following selections:

SENS – LO, PLT MIC 1, CPLT MIC 1, ALL mode, SPKR - off, Radio Audio - off.

The VOX indicator is dependent on the VOX control pot setting.

End of section 3.0

