



**SM41**

**NPX138  
PANEL MOUNT RADIO**



## **INSTALLATION AND OPERATION MANUAL**

**REV 4.00 November 10, 2003**

**Northern Airborne Technology Ltd.  
1925 Kirschner Road  
Kelowna BC, Canada  
V1Y 4N7**

**Telephone (250) 763-2232  
Facsimile (250) 762-3374**

**Copyright 2003 by Northern Airborne Technology**

## **IMPORTANT INFORMATION**

### **FOR AVIONICS INSTALLATION FACILITIES**

The NPX138 is supplied without TSO certification, as no such standard presently exists for airborne VHF/FM radio transceivers. This equipment provides what is considered as “supplemental” communications, and can be installed in an aircraft on a “Non interference” basis. Installation should be performed using standard procedures applicable to aircraft radio installation, to ensure that the newly installed equipment does not interfere with any other equipment in the aircraft.

This device complies with Part 15 of the FCC Rules. Operation is subject to the condition that this device does not cause harmful interference.

Periodically NAT will release manual amendments. In order to maintain the most accurate and up to date manual these amendments should be carried out immediately upon receipt and recorded on the following amendment record.

AMENDMENT RECORD				
Amendment Number	Amendment Date	Section(s) Changed	Date Entered	Entered By
1	Apr 19/04	2	<b>Performed at Factory</b>	
2	Aug 19/04	2	<b>Performed at Factory</b>	
3	Nov 22/04	2	<b>Performed at Factory</b>	
4	Jun 10/05	1,3	<b>Performed at Factory</b>	
5	Jan 14/08	2	<b>Performed at Factory</b>	
6	Mar 30/10	2	<b>Performed at factory</b>	

Insert any Amendment Instruction sheets after this page.

3.4.2	RX/TX Status Indicator	3-3
3.4.3	Scan/Guard TX Switch	3-4
3.4.4	Guard Controls	3-4
3.5	General Controls — Normal Operating Mode	3-5
3.5.1	Channel Switch	3-5
3.5.2	Brightness Switch	3-5
3.5.3	Squelch Pushbutton	3-6
3.6	Channel Display	3-6
3.6.1	ID Display Line	3-6
3.6.2	RX Display Line	3-7
3.6.3	TX Display Line	3-7
3.7	Channel Editing	3-8
3.7.1	SELECT Switch	3-9
3.7.2	NEXT Switch	3-9
3.7.3	EDIT Switch	3-10
3.7.4	HELP Switch	3-10
3.8	Status Editing	3-10
3.8.1	NEXT and SELECT Switch Use	3-11
3.8.2	Status Edit Features	3-11
3.9	Tones	3-12
3.9.1	General	3-12
3.9.2	Tone Display and Selection	3-13
3.9.3	Turning Tones On and Off	3-15
3.10	Scanning	3-15
3.10.1	General	3-15
3.10.2	Scan Operation	3-16
3.10.3	Scan Modes	3-16
3.11	Wideband/Narrowband Operation	3-18
3.11.1	Editing Wideband/Narrowband Flag	3-18
3.12	Configuration Mode	3-18
3.12.1	Using Configuration Mode	3-18
3.12.2	Configuration Option Table	3-19

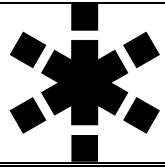

**nat**

**INSTALL\_OPS  
MANUAL AMENDMENT**

**Manual: SM41\_NPX138**

**Amendment No.: 6**

**Document No. SM41\Install\_Ops\809-0006**

**Amendment Date: Mar 30, 2010**

The purpose of this amendment is to add the current revision of the Mechanical Installation drawing.

**Amendment Instructions:**

1	Remove Pages	Replace With Pages
	Title Page	Title Page
	2-5 Rev 4.00 Amendment 2	2-5 Rev 4.00 Amendment 3

2	Remove Drawing (Section 2)	Add Drawing (Section 2)
	NPX138\922-0 Rev 1.20	NPX138\922-0 Rev 1.21

**Note:** Ensure that all drawings are inserted in the order shown on the latest drawing lists.

3 Update the Amendment Record sheet at the front of the manual.

4 Insert this page into the manual after the Amendment Record sheet (page ii).

**Manual Amendment ends after the following amended pages**

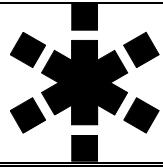

**nat**<sup>®</sup>

**INSTALL\_OPS  
MANUAL AMENDMENT**

**Manual: SM41 (NPX)**

**Amendment #: 5**

**Document # SM41\Install\_Ops\809-0005**

**Amendment Date: Jan 14, 2008**

The purpose of this amendment is to update sections 2.3.4, 2.3.5 and 2.3.6.

**Amendment Instructions:**

1

Remove Pages	Replace With Pages
2-1 and 2-2 Rev. 4.00 Amendment # 3	2-1 and 2-2 Rev. 4.00 Amendment # 5
2-3 and 2-4 Rev. 4.00	2-3 and 2-4 Rev. 4.00 Amendment # 5

2 Update the Amendment Record sheet at the front of the manual.

3 Insert this page into the manual after the Amendment Record sheet (page iii).

**Manual Amendment ends after the following amended pages**

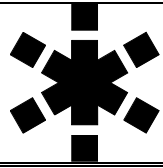

**nat**

**INSTALL\_OPS  
MANUAL AMENDMENT**

**Manual: SM41 (NPX)**

**Amendment #: 4**

**Document # SM41\Install\_Ops\809-0004**

**Amendment Date: Jun 10, 2005**

The purpose of this amendment is to add information relevant to the NPX138N-070.

**Amendment Instructions:**

1

Remove Pages	Replace With Pages
1-5 Rev 4.00	1-5 Rev 4.00 Amendment # 4
3-3 and 3-4 Rev 4.00	3-3 and 3-4 Rev 4.00 Amendment # 4
3-7 and 3-8 Rev 4.00	3-7 and 3-8 Rev 4.00 Amendment # 4
3-11 and 3-12 Rev 4.00	3-11 and 3-12 Rev 4.00 Amendment # 4
3-19 Rev 4.00	3-19 Rev 4.00 Amendment # 4

2

Update the Amendment Record sheet at the front of the manual.

3

Insert this page into the manual after the Amendment Record sheet (page ii).

**Manual Amendment ends after the following amended pages**

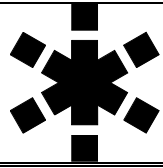

**nat**<sup>®</sup>

**INSTALL\_OPS  
MANUAL AMENDMENT**

**Manual: SM41 NPX138**

**Amendment #: 3**

**Document # SM41\Install\_Ops\809-0003**

**Amendment Date: Nov 22, 2004**

The purpose of this amendment is to amend the cable and wiring specifications in line with Transport Canada requirements.

**Amendment Instructions:**

1	Remove Pages	Replace With Pages
	2-1 and 2-2 Rev 4.00	2-1 and 2-2 Rev 4.00 Amendment #3

2 Update the Amendment Record sheet at the front of the manual.

3 Insert this page into the manual after the Amendment Record sheet (page ii).

Manual Amendment ends after the following amended pages

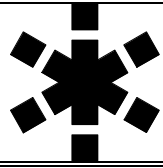

**nat**

**INSTALL\_OPS  
MANUAL AMENDMENT**

**Manual: SM41 NPX138**

**Amendment #: 2**

**Document # SM41\Install\_Ops\809-0002**

**Amendment Date: Aug 19, 2004**

The purpose of this amendment is to update the faceplate drawing.

**Amendment Instructions:**

1	Remove Pages	Replace With Pages
	2-5	2-5 Amendment #2
2	Remove Drawings (Section 2)	Replace or add Drawings (Section 2)
	NPX138\905-0 rev 1.40	NPX138\905-0 rev 1.50

**Note:** Ensure that all drawings are inserted in the order shown on the latest drawing lists.

3 Update the Amendment Record sheet at the front of the manual.

4 Insert this page into the manual after the Amendment Record sheet (page ii).

Manual Amendment ends after the following amended pages

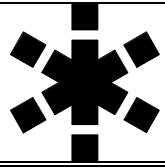

**nat**

**MANUAL AMENDMENT**

**Manual: SM41 NPX138**

**Amendment #: 1**

**Document # SM41\Install\_Ops\809-0001**

**Amendment Date: Apr 19, 2004**

The purpose of this amendment is to include the new revision of the NPX138\634-0 in the manual.

**Amendment Instructions:**

1	Remove Page	Replace With Page
	2-5 rev 4.00	2-5 rev 4.00 Amendment #1
2	Remove Drawings (Section 2)	Replace or add Drawings (Section 2)
	NPX138\634-0 rev 1.00	NPX138\634-0 rev 1.10

**Note:** Ensure that all drawings are inserted in the order shown on the latest drawing lists.

3 Update the Amendment Record sheet at the front of the manual.

4 Insert this page into the manual after the Amendment Record sheet (page ii).

Manual Amendment ends after the following amended pages

## Table of Contents

Section	Title	Page
1.0	Description	
1.1	Introduction	1-1
1.2	Purpose of Equipment	1-1
1.3	Features	1-1
1.4	Specifications	1-2
1.4.1	Electrical Specifications	1-2
1.4.2	Receiver	1-2
1.4.3	Transmitter	1-3
1.4.4	Physical Specifications	1-3
1.4.5	Environmental Specifications	1-4
1.5	Unit Nomenclature	1-4
1.5.1	Narrowband Capability	1-4
1.5.2	Options	1-4
1.5.3	Special Options	1-5
1.5.4	Voice Inversion Encryption	1-5
2.0	Installation	
2.1	Introduction	2-1
2.2	Unpacking and Inspection	2-1
2.3	Installation Procedures	2-1
2.3.1	Warnings	2-1
2.3.2	Cautions	2-1
2.3.3	Notes	2-2
2.3.4	Cabling and Wiring	2-2
2.3.5	Antennas	2-3
2.3.6	Mechanical Mounting	2-4
2.3.7	Post-Installation Checks	2-4
2.3.8	Post Installation EMI Test	2-5
3.0	Operation	
3.1	Introduction	3-1
3.2	Initial Operation	3-1
3.2.1	Power-up Help	3-1
3.2.2	Initial Operating Display	3-2
3.3	Display	3-2
3.4	Function Controls	3-3
3.4.1	Main RX (Receive) Volume Control	3-3

3.4.2	RX/TX Status Indicator	3-3
3.4.3	Scan/Guard TX Switch	3-4
3.4.4	Guard Controls	3-4
3.5	General Controls — Normal Operating Mode	3-5
3.5.1	Channel Switch	3-5
3.5.2	Brightness Switch	3-5
3.5.3	Squelch Pushbutton	3-6
3.6	Channel Display	3-6
3.6.1	ID Display Line	3-6
3.6.2	RX Display Line	3-7
3.6.3	TX Display Line	3-7
3.7	Channel Editing	3-8
3.7.1	SELECT Switch	3-9
3.7.2	NEXT Switch	3-9
3.7.3	EDIT Switch	3-10
3.7.4	HELP Switch	3-10
3.8	Status Editing	3-10
3.8.1	NEXT and SELECT Switch Use	3-11
3.8.2	Status Edit Features	3-11
3.9	Tones	3-12
3.9.1	General	3-12
3.9.2	Tone Display and Selection	3-13
3.9.3	Turning Tones On and Off	3-15
3.10	Scanning	3-15
3.10.1	General	3-15
3.10.2	Scan Operation	3-16
3.10.3	Scan Modes	3-16
3.11	Wideband/Narrowband Operation	3-18
3.11.1	Editing Wideband/Narrowband Flag	3-18
3.12	Configuration Mode	3-18
3.12.1	Using Configuration Mode	3-18
3.12.2	Configuration Option Table	3-19

## Section 1.0 Description

### 1.1 Introduction

---

This manual contains description, installation, operation and maintenance information on the NPX138 series of panel mount FM transceivers, serial numbers 1238 and subsequent.

The NPX138 incorporates NAT's proven user-friendly operating system with on-line help, making it easy to program and use. The small size makes this radio ideal for airframes where size and weight are a factor.

### 1.2 Purpose of Equipment

---

The NPX138 panel mount FM transceiver is a stand-alone radio designed for the single mission user. It provides all the features needed to satisfy FM communications within the VHF-FM high band.

### 1.3 Features

---

The NPX138 covers a frequency range of 138.000 MHz to 173.995 MHz in 5.0/6.25 kHz increments. Each of the 100 available channels can include a receive frequency and CTCSS tone, transmit frequency and CTCSS tone, and an alpha/numeric identifier.

A SCAN function allows scanning of selected channels. Transmit power of either 1 watt or 10 watts is selectable from the front of the NPX138. Simplex and semi-duplex operations are available. An optional guard receiver is available with some models.

DTMF encoding and direct keyboard entry can be effected by the use of the DTE12, an accessory available from NAT.

Conveniently located beside the display are separate main volume, guard volume and transmit select switches. Easily identified along the bottom of the front panel are squelch test, channel up/down and display brightness controls. The aircraft dimmer buss provides control for the panel lighting.

Depending on model selected the NPX138 can provide wideband ( $\pm 5.0$  kHz Rated System Deviation) and/or narrowband ( $\pm 2.5$  kHz Rated System Deviation) by channel. Compensation circuitry ensures that the average receive audio level remains constant when the mode changes.

## 1.4 Specifications

---

### 1.4.1 Electrical Specifications

---

Input power	28 Vdc nominal
Current consumption	0.5 A receive/2.0 A transmit (typical) 0.8 A receive/3.0 A transmit (max.)
Panel lighting	28 Vdc, 14 Vdc or 5 Vdc dependent on model.
Sidetone output	25 mW @ 600 $\Omega$ , adjustable.
Microphone	Amplified Dynamic or equivalent, 150 $\Omega$ balanced/unbalanced
Frequency range	138.000 MHz to 173.995 MHz
Tone capability	38 standard CTCSS tones
Operating mode	simplex or semi-duplex

### 1.4.2 Receiver

---

Channel increments	5 kHz/6.25 kHz
Audio output	100 mW @ 600 $\Omega$ Bal/Unbal
Sensitivity	
Main	0.5 $\mu$ V max. @ 12 dB SINAD
Guard	0.5 $\mu$ V max. @ 12 dB SINAD
Spurious response rejection	70 dB
Adjacent channel rejection	
NPX138 (all models)	70 dB min. @ $\pm$ 25 kHz
NPX138N (all models)	
Wideband	70 dB min. @ $\pm$ 25 kHz
Narrowband	60 dB min. @ $\pm$ 12.5 kHz
Intermodulation rejection	70 dB
Hum and Noise ratio	
Unsquelled	> 50 dB
Squelled	< -80 dBw
Distortion	< 4% @ rated output

### 1.4.3 Transmitter

---

RF power output	1 W/10 W Selectable
RF input/output impedance	50 $\Omega$ nominal
Rated System Deviation	
NPX138 (all models)	$\pm 5.0$ kHz max, limited
NPX138N (all models)	
Wideband	$\pm 5.0$ kHz max, limited
Narrowband	$\pm 2.5$ kHz max, limited
Microphone Audio Sensitivity	100 mVrms into 150 $\Omega$ for 60% of rated system deviation
Conducted spurious emissions	
High power	-64 dBc
Low power	-55 dBc
Carrier frequency stability	$\pm 0.0003$ %
FM hum and noise ratio	>40 dB
AM hum and noise ratio	>35 dB
Distortion	<4 %

### 1.4.4 Physical Specifications

---

Height	1.88 inches (47.7 mm)
Overall depth	8.64 inches (219.5 mm)
Depth behind panel	7.66 inches (194.6 mm)
Width	5.75 inches (146.1 mm)
Weight	3.0 lbs. (1.4 kg)
Mounting	Std. Dzus mounting (4 fasteners)
Connector type	25 pin D-subminiature male (pins)
Antenna connector	BNC female

### 1.4.5 Environmental Specifications

---

Operating temperature	-30 C to +60 C
Altitude	25,000 feet
Humidity	95%
Vibration	DO-160C, Cat. M

### 1.5 Unit Nomenclature

---

Variants of the NPX138 series radios are identified as follows:

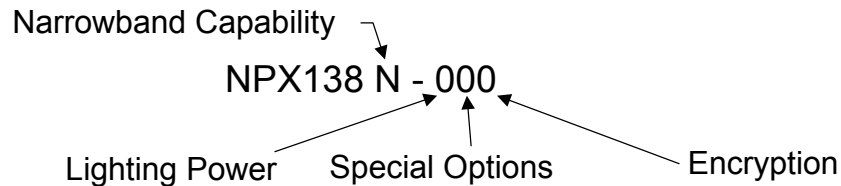

#### 1.5.1 Narrowband Capability

---

If the unit under consideration has the letter N after the NPX138 designation, it has the capability for narrowband selection in addition to wideband. If this part of the name is blank, the unit has wideband capabilities only.

NPX138 **N** - 000

<b>N</b>	=	Wideband and Narrowband modulation
<b>Blank</b>	=	Wideband modulation only

#### 1.5.2 Lighting Power

---

The digit in the first position of the unit suffix indicates the lighting power used.

NPX138 N - **0**00

<b>0</b>	=	28 Vdc Lighting
<b>1</b>	=	14 Vdc Lighting
<b>2</b>	=	28 Vdc NVG NVIS A Compliant
<b>5</b>	=	5 Vdc Lighting
<b>7</b>	=	28 Vdc NVG Compatible Lighting
<b>8</b>	=	14 Vdc NVG Compatible Lighting
<b>9</b>	=	5 Vdc NVG Compatible Lighting

### 1.5.3 Special Options

---

The digit in the second position of the unit suffix indicates any special options installed.

NPX138 N - 000

<b>0</b>	=	No Special options installed
<b>5</b>	=	USFS Standard Guard
<b>6</b>	=	Custom Guard - consult factory for details
<b>7</b>	=	Synthesized Guard
<b>Other</b>	=	Special options installed - consult factory for details

### 1.5.4 Voice-Inversion Encryption

---

The digit in the third position of the unit suffix indicates whether voice inversion encryption is installed.

NPX138 N - 000

<b>0</b>	=	No Encryption
<b>1</b>	=	Encryption

End of section 1.0

## Section 2.0 Installation

### 2.1 Introduction

---

Information in this section consists of: unpacking and inspection procedures, installation procedures, post-installation checks, and installation drawings.

### 2.2 Unpacking and Inspection

---

Unpack the equipment carefully, and locate the warranty card. Inspect the unit visually for damage due to shipping and report all such claims immediately to the carrier involved. Note that each unit should have the following:

- NPX138 Radio
- Warranty Card
- Operator's Manual
- Release certification

Verify that all items are present before proceeding, and report any shortage immediately to your supplier.

Complete the warranty card information, and send it to NAT when the installation is complete. If you fail to complete the warranty card, the warranty will be activated on date of shipment from NAT.

### 2.3 Installation Procedures

---

#### 2.3.1 Warnings ← **IMPORTANT!**

---

Do not bundle any lines from this unit with **transmitter coax lines**. Do not bundle any logic, audio, or DC power lines from this unit with 400 Hz synchro wiring or AC power lines. Do not position this unit next to any device **with a strong alternating magnetic field such as an inverter or significant interference to operation will result.** In all installations, use shielded cable exactly as shown and **ground as indicated.** Significant problems may result if these guidelines are not followed.

#### 2.3.2 Cautions

---

All audio installations can be severely degraded by incorrect wiring and shielding, and may result in much higher cross-talk, hum, and ground-loop interference. This should be considered when audio wiring to and from the radio installation is performed.

### 2.3.3 Notes

---

The case of the NPX138 must be electrically grounded for maximum resistance to low frequency interference. A pin on the connector (Chassis ground) is provided and must be connected by a short wire to a clean ground, not jumpered to the power ground wire connection.

Refer to the aircraft structural repair manual and maintenance manual for instructions and information pertinent to this installation.

### 2.3.4 Cable and Wiring

---

All unshielded wire shall be selected in accordance with the original aircraft manufacturer's maintenance instructions or AC43.13-1B Change 1, Paragraphs 11-76 through 11-78. Wire types should be to MIL-W-22759 as specified in AC43.13-1B Change 1, Paragraphs 11-85, 11-86, and listed in Table 11-11. For shielded wire applications, use Tefzel MIL-C-27500 shielded wire with solder sleeves (for shield terminations) to make the most compact and easily terminated interconnect. Follow the wiring diagrams in Section 2.5 as required.

Allow 3 inches from the end of the wire to the shield termination to allow the hood to be easily installed. Note that the hood is installed after the wiring is complete.

Installation cabling must allow the NPX138 to be easily withdrawn for disconnection and field service adjustments. Ensure an adequate service loop in the routing of the cables. It can be a serious issue if the unit is installed with the cables so short that the unit cannot be removed without disassembly of the surrounding structures. At least 30 cm (1 foot) of free cable is recommended.

All wiring should be 22 AWG minimum, except power and ground connections, which must be 20 AWG or larger, as indicated on the installation drawings. Ensure that the ground connection is clean and well secured. To prevent inadvertent system failure, power to this system must be supplied from a separate breaker or fuse and not connected to any other device. A 5 A fuse or breaker is recommended (28 Vdc).

Coaxial cable should be in accordance with MIL-C-17 unless otherwise specified. Do not use coax with PVC insulation. Teflon dielectric cable is encouraged at or above VHF frequencies or where cable runs exceed 8 feet. Note that at VHF frequencies, cable losses due to long cable runs and tight bends may cut the ERP (Equivalent Radiated Power) to less than 50% of spec.

To prevent RF interference between similar systems, it is recommended that VHF FM coax runs be widely separated, or be made using triaxial cable, with the outer shield bonded to the airframe at one end only (transceiver end).

In communication intensive applications, poor cable routing and shielding may drastically compromise over-all system performance. Symptoms may be spurious squelch opening, RFI (Radio-Frequency Interference), and garbled reception.

RF cables must be neatly terminated (solder or crimp), and tested for shorts prior to system check-out (**not** while connected to the radio or antenna). Keep cable bends to a minimum at the antenna. Avoid sharp bends in the coax cables (minimum 3" radius) to prevent severe reflections. If sharp bends are required, use 90° elbow adapters.

Fabrication & installation of wiring harness should be in accordance with the original aircraft manufacturer's maintenance instructions or AC 43.13-1B Change 1, chapter 11, sections 5 to 13, 16 and 17.

Grounding and bonding should be in accordance with the original aircraft manufacturer's maintenance instructions or AC 43.13-1B Change 1, chapter 11, section 15.

### 2.3.5 Antennas

Correct antenna placement and mounting is critical in order to achieve the best possible performance. In general, keep all antennas as widely separated as possible and clear of any large airframe obstructions.

Installation of the antenna should be in accordance with the original aircraft manufacturer's instructions for continued airworthiness or AC 43.13-1B Change 1, chapter 11, section 15 and AC 43.13-2A chapter 3. If possible, the antenna should be located a minimum of 12 ft from aircraft navigation receiver antennas and a minimum of 4 feet from aircraft communications and ELT antennas. Be careful not to choose separations that closely approximate  $\frac{1}{4}$ ,  $\frac{1}{2}$  or whole-number multiples of the navigation or communications system wavelength.

**Note:** Avoid any placement that puts antennas of like frequencies close together.

Bottom mounted antennas will perform best in flight, but poorest on the ground during testing. Antennas may be severely degraded by 'masking' effects of the fuselage or stabilizers, and generally give best performance when bottom mounted.

To reduce interference from rotor modulation and other undesirable stimuli, any blade or whip antenna must be surrounded by a ground plane surface (metallic, grounded material) with a radius equal to or greater than the height of the antenna. Under the same conditions, the antenna is also much less likely to cause interference to other aircraft systems (e.g. coupling into audio system, fluctuations in instrumentation, etc.). Poor grounding will result in severe reflected power and high levels of RFI throughout the airframe.

Avoid antenna locations that will become fouled with oil, water, fuel or dirt, as this will degrade performance. Roof mounts (in close proximity to rotor blades) are permissible.

### 2.3.6 Mechanical Mounting

Installation of the transceiver should be in accordance with the original aircraft manufacturer's instructions for continued airworthiness or AC 43.13-1B Change 1, chapter 7, sections 2 to 7 and AC 43.13-2A, chapter 2. Pr 35 Dzus rail or equivalent may be used.

Mounting the NPX138 requires a Dzus rail assembly with an opening width of 127 mm (5 inches) and a front clearance width of 146.1 mm (5.75 inches). Height requirement is 47.6 mm (1.875 inches). Refer to the mounting drawings and unit mechanical specifications to determine proper clearance dimensions. Be sure that adequate clearance is allowed for the cable connections to each unit.

### 2.3.7 Post-Installation Checks

#### 2.3.7.1 Voltage/resistance checks

**Do not attach the NPX138 until the following conditions are met.**

Check the following:

- a) P101 pins <12> and <13> for +28 Vdc relative to ground.
- b) P101 pins <22>, <23>, <24> and <25> for continuity to ground (below 0.5  $\Omega$ ).
- c) Light voltage as per table below.

	P101 Pin #	Voltage
28 Volt Models	11	28 Vdc
14 Volt Models	10	14 Vdc
5 Volt Models	10	5 Vdc

Light Voltage

**Ensure that the antenna is disconnected for the following test or erroneous readings may be obtained**

- d) Radio coax connector for continuity to the antenna coax connector (shield and center conductor), and for open circuit from the center conductor to ground and open circuit from the center conductor to the shield.

### 2.3.7.2 Power On Checks

- a) Install the NPX138 and power up the ship's systems. Turn on the radio. Check the operation of all front panel controls. Adjust brightness and volume levels as required.
- b) Check all transmit and receive functions. Ensure the RX/TX status indicator lights green when the radio is keyed to transmit and amber when receiving.
- c) Check the SCAN function. Note: you **may be unable to hear the received audio** if the tones do not match those set in the radio. To avoid any confusion, tones should be set to **OFF** (via the status edit mode) during scanning so that all channels will be heard.
- d) Check the antenna feedline at the R/T with a through-line wattmeter and suitable frequency elements to ensure correct antenna matching. Reflected power in excess of 25% represents a serious problem, and should be investigated carefully, or serious RFI and system interference as well as possible radio damage may result. A VSWR measurement over 3.0:1 represents a significant loss in signal power to the antenna. Check that forward power is to specifications over the frequency band of the radio.

### 2.3.8 Post Installation EMI Test

The purpose of this test is to identify any interference that the NPX138 may cause with existing aircraft systems. The NPX138 should be tested in accordance with the Installation Approval Test Procedure (see section 2.5), and the test results documented on the record sheets.

### 2.4 Continued Airworthiness

Maintenance of the NPX138 is 'on condition' only. Periodic maintenance of these products is not required.

### 2.5 Installation Drawings

DRAWING	REV.	DESCRIPTION	TYPE
NPX138\403-0	1.40	Panel Mount Radio	Interconnect
NPX138\403-1	1.00	Panel Mount Radio	Interconnect
NPX138\405-0	1.20	Panel Mount Radio	Connector Map
NPX138\634-0	1.10	Post Installation EMI Test	Installation Approval Test Procedure
NPX138\905-0	1.50	Panel Mount Radio	Faceplate
NPX138\922-0	1.21	Panel Mount Radio	Mechanical

Section 2.0 ends after these Drawings

REVISIONS			
REV	DESCRIPTION	DATE	BY
1.10	GENERATION OF -050 DWG'S. SEE ECR #502	NOV 23/95	KEH
1.20	ECR #502: ADDED 14V TO PIN 10	JUN 25/96	TGM
1.31	ECR #809: REV AND DWG # CORRECTION.	MAY 21/97	TGM
1.40	ECR #967: PINS 5, 6, 16, & 17 REASSIGNED.	SEP 17/97	KEH

NPX138/NPX138N  
VHF FM TRANSCEIVER

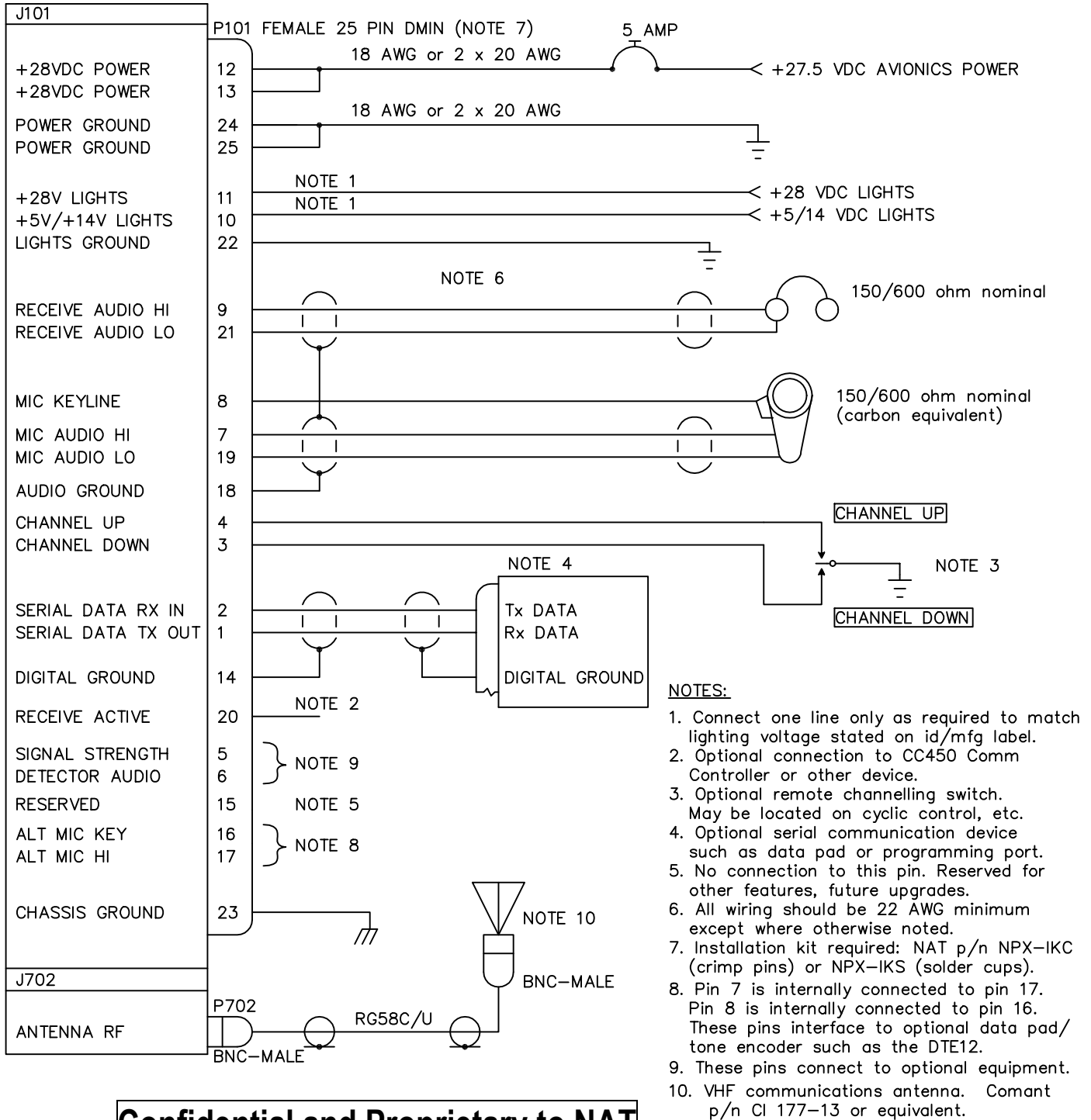

**Confidential and Proprietary to NAT**

DESIGNED	KEH	<b>NAT</b> NORTHERN AIRBORNE TECHNOLOGY LTD.				
DRAWN	KEH					
DATE	APR 27/95	TITLE	PANEL MOUNT VHF FM TRANSCEIVER			
CHECKED	NAT 201	SIZE	CAGE CODE	PART NO.	REV.	SHEET
APPROVED	NAT 107	A	3AB01	NPX138/NPX138N	1.40	1/1
FILE	403-0140.DWG	DWG. TYPE	INTERCONNECT	DWG. NO.	NPX138\403-0	

NPX138/NPX138N  
VHF FM TRANSCEIVER

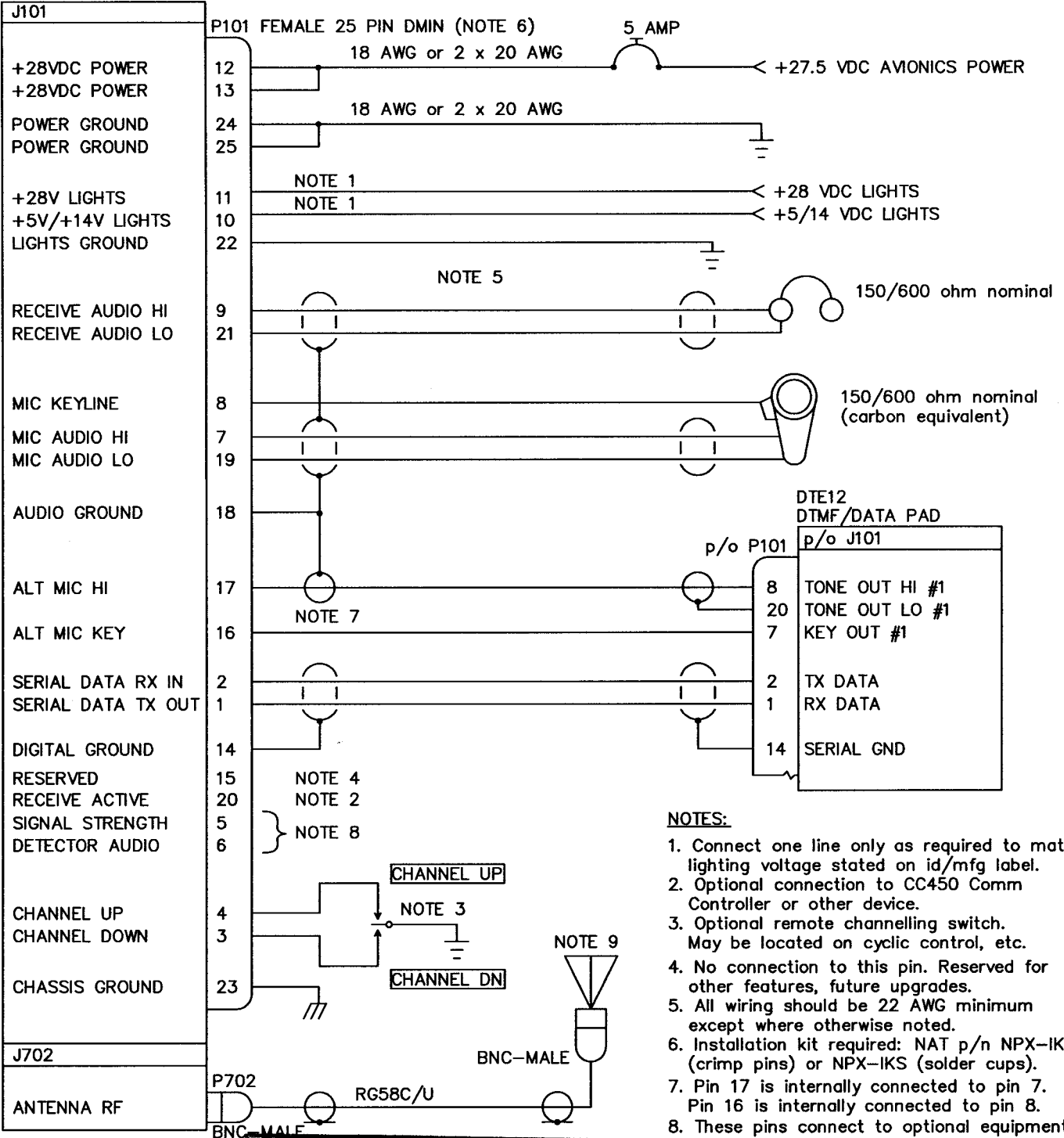

- NOTES:**
1. Connect one line only as required to match lighting voltage stated on id/mfg label.
  2. Optional connection to CC450 Comm Controller or other device.
  3. Optional remote channelling switch. May be located on cyclic control, etc.
  4. No connection to this pin. Reserved for other features, future upgrades.
  5. All wiring should be 22 AWG minimum except where otherwise noted.
  6. Installation kit required: NAT p/n NPX-IKC (crimp pins) or NPX-IKS (solder cups).
  7. Pin 17 is internally connected to pin 7. Pin 16 is internally connected to pin 8.
  8. These pins connect to optional equipment.
  9. VHF communications antenna. Comant p/n CI 177-13 or equivalent.

**Confidential and Proprietary to NAT**

DESIGNED	KEH	<b>*nat</b> NORTHERN AIRBORNE TECHNOLOGY LTD.				
DRAWN	KEH					
DATE	SEP 17/97	TITLE	PANEL MOUNT VHF FM TRANSCEIVER CONNECTING TO A DTE12			
CHECKED	NAT 201	SIZE	CAGE CODE	PART NO.	REV.	SHEET
APPROVED	NAT 107	A	3AB01	NPX138/NPX138N	1.00	1/1
FILE	403-1100.DWG	DWG. TYPE	INTERCONNECT	DWG. NO.	NPX138\403-1	

REVISIONS			
REV	DESCRIPTION	DATE	BY
1.01	GENERATION OF -050 DWG'S. SEE ECR #502	APR 30/95	KEH
1.10	ECR #502: ADDED 14V TO PIN 10	JUN 25/96	TGM
1.20	ECR #967: WAS NPX138\050\403-0110.DWG PINS 5, 6, 16, & 17 REASSIGNED.	SEP 17/97	KEH

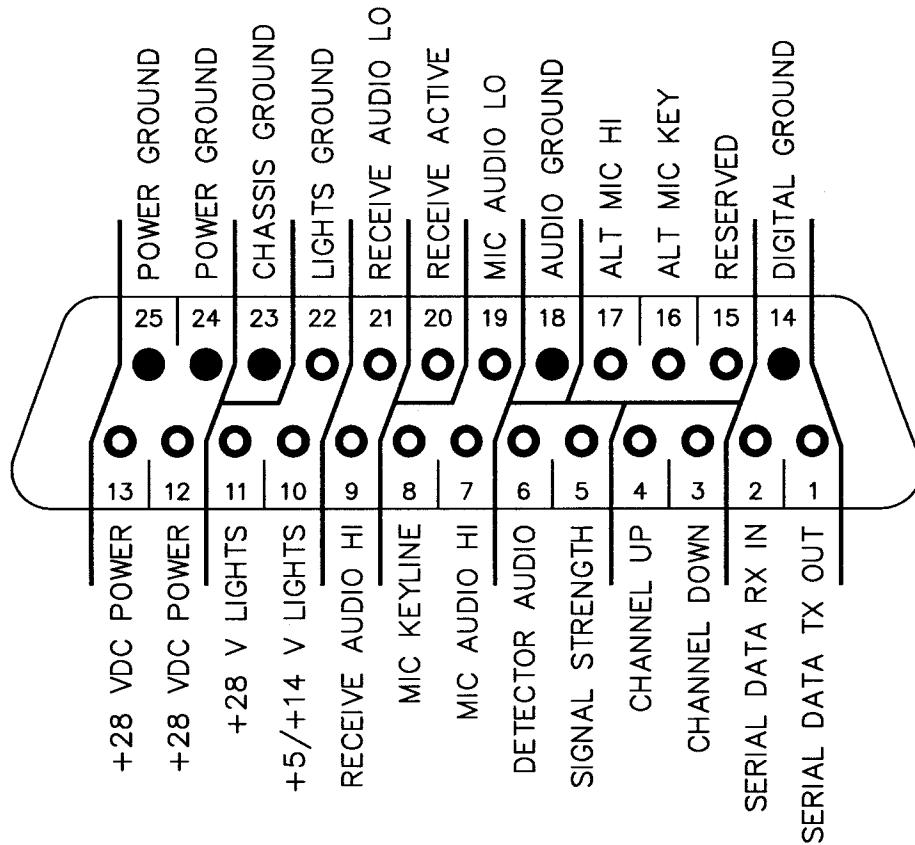

● : SOLID CIRCLES DENOTE INTERNALLY CONNECTED GROUND PINS.  
VIEW: REAR SIDE OF AIRFRAME CONNECTOR  
TYPE: AIRFRAME CONNECTOR IS 25-PIN D-SUBMINIATURE FEMALE (SOCKETS)

**Confidential and Proprietary to NAT**

DESIGNED	KEH	<b>*nat</b> NORTHERN AIRBORNE TECHNOLOGY LTD.				
DRAWN	KEH					
DATE	APR 27/95	TITLE PANEL MOUNT VHF FM TRANSCEIVER				
CHECKED	NAT 201					
APPROVED	NAT 107	SIZE A	CAGE CODE 3AB01	PART NO. NPX138/NPX138N	REV. 1.20	SHEET 1/1
FILE	405-0120.DWG	DWG. TYPE	CONNECTOR MAP	DWG. NO.	NPX138\405-0	



# INSTALLATION APPROVAL TEST PROCEDURE

NAT Part #: **NPX138**  
Document #: **NPX138\634-0**

Description: **Panel Mount Radio**  
Rev: **1.10**

## 1. Post Installation EMI Test

---

The purpose of this test is to identify any interference that the NPX138 may cause with existing aircraft systems.

## 2. Test Conditions

---

The NPX138 should be installed and function tested. The antenna VSWR should be checked. A forward/reverse power check with an in-line wattmeter should show no more than 10% reflected power. For the following tests, insure that the transmit power is set to HI.

## 3. Methodology

---

Most of the EMI tests can be accomplished on the ground. In some cases, flight testing is required or is easier. If the aircraft is approved for IFR operations, then it is mandatory that interference between the NPX138 and the approach aids be checked in flight.

The GPS should be operational and navigating with at least the minimum compliment of satellites. The VHF comm should be set to the frequencies indicated with the squelch open. VOR/ILS/GS receivers should be set to the frequencies indicated and selected for display. If possible, set up a VOR/ILS ramp test set on the frequencies indicated and adjust the output until the flags are out of view. The transponder and encoder should be monitored with ramp test equipment. If possible set the ADF to a nearby navigation station.

Modulate the NPX138 transmitter on the indicated frequencies for at least 20 seconds. Observe the GPS for any degradation in satellite status or availability or flags. Listen for any noise or detected audio signals on the VHF comm(s). Listen for any noise or detected audio signals on the VOR/LOC receiver audio; look for any movement of flags or needles on the VOR/LOC/GS navigation display(s).

List the power plant, fuel and other electric instruments in the chart provided and note any anomalies that occur while transmitting. Assess the results.

If the aircraft is equipped with an autopilot or a stability augmentation system, then test fly the aircraft and verify that the operation of the NPX138 transceiver does not have adverse effects on these systems. After checking for gross effects at a safe altitude, fly an approach with each of the different navigation systems coupled to the autopilot (ILS, GPS etc.) and look for any anomalies.

#### 4. Results

If the installed system passes all of the applicable EMI tests, then no further action is required. If interference is observed, then the interference must be assessed against the appropriate standards of airworthiness for the system in question. For example: it is permissible for a VFR certified GPS to lose navigation capability while the NPX138 is transmitting, providing that it recovers properly and promptly, but it is not permissible for an IFR Approach certified GPS to be affected in the same way. A complete discussion of all the standards of airworthiness to be applied in assessing EMI effects is beyond the scope of this document.

#### 5. Procedure

- A. Operate the NPX138 transmitter on the following frequencies for at least 20 seconds. Observe the GPS for any degradation in satellite status, or availability, or flags.

FREQUENCIES	GPS #1		GPS #2	
	PASS	FAIL	PASS	FAIL
143.2187 MHz				
143.2200 MHz				
153.4500 MHz				
157.5400 MHz				
157.5437 MHz				

NOTES:

- B. Determine if the image frequency for the VHF Comm falls within the range of the NPX138 unit. If so, select a set of frequencies that will cause the NPX138 to be set as close as possible to the image frequency. Any one of the many possible sets will suffice. Record these values in the spaces provided in the following chart. Modulate the NPX138 transmitter on the following frequencies for at least 20 seconds. Listen for any noise or detected audio signals on the VHF comm.

Example - Bendix/King KY 196A:

The first IF frequency is 11.4 MHz. The L.O. is above the received frequency (high side injection), therefore the image frequency is 22.8 MHz above the selected frequency. Set the KY 196A to 120.000 MHz and the NPX138 to 142.8000 MHz.

FREQUENCIES		RESULTS	
VHF #1	NPX138	PASS	FAIL
135.975	138.0000		
121.150	157.5000		
131.250	157.5000		
Image:			

FREQUENCIES		RESULTS	
VHF #2	NPX138	PASS	FAIL
135.975	138.0000		
121.150	157.5000		
131.250	157.5000		
Image:			

NOTES:

- C. Determine if the image frequency for the VOR/ILS Nav falls within the range of the NPX138 unit. If so, select two sets of frequencies that will cause the NPX138 to be set as close as possible to the image frequency. Choose one set in the localizer frequency range, and one in the VOR frequency range. Record these values in the spaces provided in the following chart. Modulate the NPX138 transmitter on the following frequencies for at least 20 seconds. Listen for any noise or detected audio signals on the receiver audio; look for any movement of flags or needles on the navigation display.

FREQUENCIES		RESULTS	
VOR/ILS #1	NPX138	PASS	FAIL
108.000	162.0000		
108.100	162.1500		
Image:			
Image:			

FREQUENCIES		RESULTS	
VOR/ILS #2	NPX138	PASS	FAIL
108.000	162.0000		
108.100	162.1500		
Image:			
Image:			

NOTES:

- D. Modulate the NPX138 transmitter on the following frequencies for at least 20 seconds. Look for any movement of flags or needles on the navigation display.

FREQUENCIES		RESULTS	
G/S #1	NPX138	PASS	FAIL
334.7 (108.1)	167.3500		

FREQUENCIES		RESULTS	
G/S #2	NPX138	PASS	FAIL
334.7 (108.1)	167.3500		

NOTES:

**Note:** For the following tests, select frequencies at the top, middle and bottom of the range of the NPX138.

Frequency #1 \_\_\_\_\_ Frequency #2 \_\_\_\_\_

Frequency #3 \_\_\_\_\_

- E. At a safe altitude, engage the autopilot or stability augmentation system. Modulate the NPX138 transmitter on the above frequencies for at least 20 seconds. Observe any effect on the autopilot or stability augmentation system.

Observations:

- F. Perform a coupled ILS approach to the aircraft's certified limits. Modulate the NPX138 transmitter on the above frequencies for at least 20 seconds. Observe any effect on the autopilot. Repeat for each different system such as ILS #2, GPS, FMS etc.

Observations:

- G. List the power plant, fuel and other electric instruments in the chart provided and note any anomalies that occur while transmitting. Assess the results.

STEP	SYSTEM	PASS	FAIL	NOTES
1	Xponder & Encoder			
2	ADF 1 & 2			
3	VG			
4	Compass			
5	Directional Gyro			
6	Oil Pressure			
7	Fuel Pressure			
8	Oil Temp			
9	Amps			
10	Bus Voltage			
11	Fuel %			
12	Ng			
13	TOT			
14	Torque %			
15	Annunciators			
16	Digital Clock			



STEP	SYSTEM	PASS	FAIL	NOTES

NOTES:

End of Installation Approval Test Procedure

REVISIONS			
REV	DESCRIPTION	DATE	BY
1.10	ECR 354 – MECH. CHANGES	NOV 9/95	KEH
1.11	FORMAT CHANGES	APR 19/96	KEH
1.20	ECR #534, ENGRAVE LAYER AND SHEET 2 ADDED.	SEP 25/96	TGM
1.30	ECR #930 "NPX138" TEXT MOVED LEFT PART No. CHANGED FROM NPX138-050 TO NPX138	AUG 7/97	MWS
1.40	ECR #1017 – NPX TEXT WAS NPX138.	OCT 29/97	TGM
1.50	ECR #2018-HOLE 'A' WAS QTY 4,HOLE 'C' WAS QTY 2	AUG 07/02	MWS

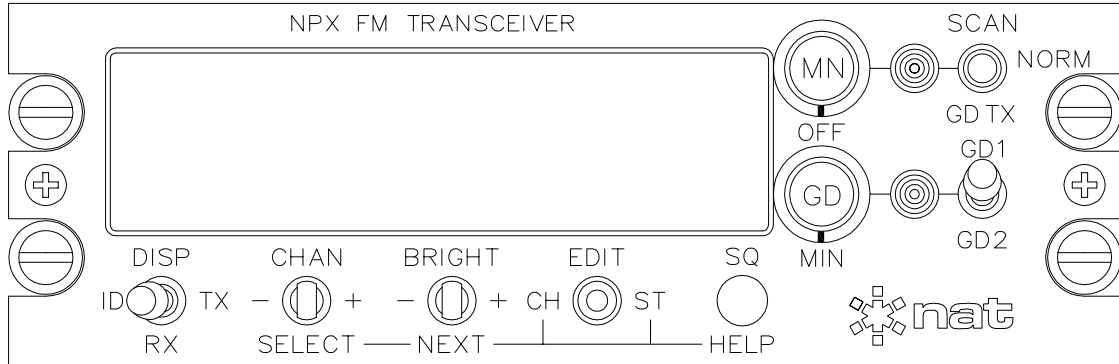

CONFIDENTIAL AND PROPRIETARY TO NAT LTD.

DESIGNED	KEH	 <b>NORTHERN AIRBORNE TECHNOLOGY LTD.</b>				
DRAWN	KEH					
DATE	APR 27/95	TITLE NPX138 PANEL MOUNT TRANSCEIVER				
CHECKED	<b>NAT 241</b>					
APPROVED	<b>NAT 113</b>	SIZE A	CAGE CODE 3AB01	PART NO. NPX138	REV. 1.50	SHEET 1/2
FILE	905-0150.DWG	DWG. TYPE FACEPLATE		DWG. NO.	NPX138\905-0	

REVISIONS			
REV	DESCRIPTION	DATE	BY
-	FOR PREVIOUS REVISIONS REFER TO REV 1.20 DWG.	-	-
1.21	DOCCR02894 - REPL'D NAT LABEL WITH WED LABEL.	MAR 02/10	MWS

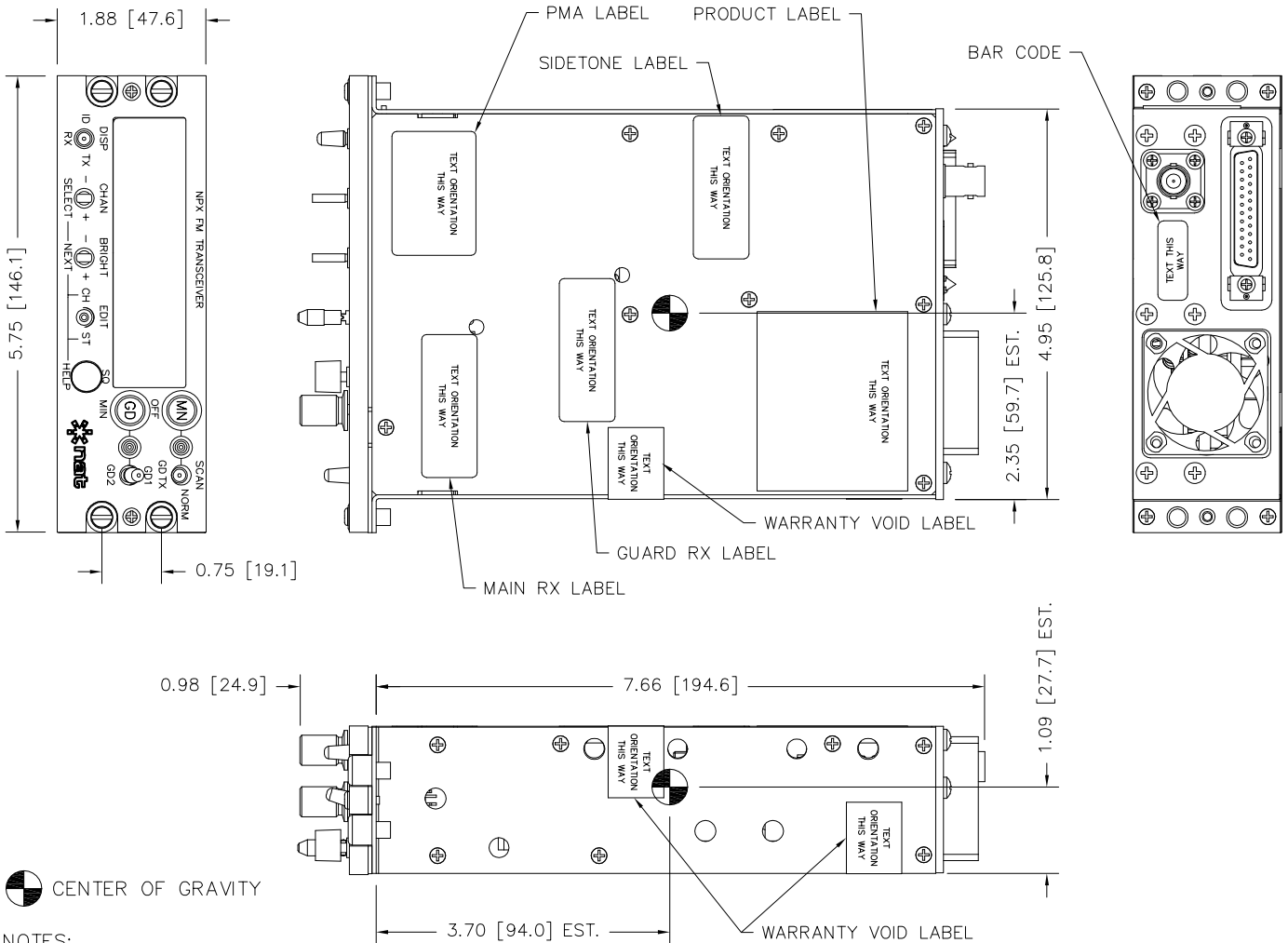
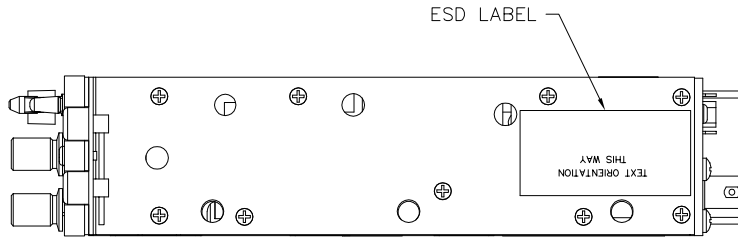

- NOTES:
- DIMENSIONING AND TOLERANCING IN ACCORDANCE WITH ASME Y14.5M-1994
  - WEIGHT: 3.3 lbs (1.5 Kg) MAX  
2.7 lbs (1.23 Kg) MIN

CONFIDENTIAL AND PROPRIETARY TO NAT LTD.

TOLERANCES UNLESS STATED OTHERWISE 0.X=+/-0.030 0.XX=+/-0.010 0.XXX=+/-0.005 0.XXXX=+/-0.002 ANGLE=+/- 0.5 DEG.	DIMENSIONS IN INCHES THIRD ANGLE PROJECTION	DESIGNED	KEH	<b>NAT</b> NORTHERN AIRBORNE TECHNOLOGY LTD.									
		DRAWN	KEH		TITLE								
		DATE	APR 27/95	NPX138 PANEL TRANSCEIVER									
		CHECKED	NAT 201	NAT 255									
WEIGHT: SEE NOTE 2.		APPROVED	NAT 114	SIZE	A	CAGE CODE	3AB01	PART NO.	NPX138	REV.	1.21	SHEET	1/1
MATERIAL: -		FILE	922-0.DWG	DWG. TYPE	MECH. INSTALLATION	DWG. NO.	NPX138\922-0						
FINISH: -													

## Section 3.0 Operation

### 3.1 Introduction

In addition to the general functions that are available on other FM radios, the NPX has several features that extend its capability and make it easier to use. These features include alphanumeric channel labeling, built-in operator help, scanning, optional guard receiver, and numerous others.

For ease of use and operability, NAT uses the same control layout and operating system in the NPX138 series of radios as it does in its popular Tac/Com family of radio control heads.

In addition to this manual, there is a help function built into the radio comprehensive enough to address most operational questions.

Many of the front panel controls have more than one function, dependent on the operating mode of the radio. For this reason, they have multiple labels. When the radio is in 'Normal' mode (**EDIT** switch in the center 'Off' position), use the top label and when the radio is in 'Edit' mode (either 'CH' or 'ST'), use the bottom label.

### 3.2 Initial Operation

#### 3.2.1 Power-up Help

Turn the NPX on by rotating the main volume control clockwise, away from the 'Off' detent position. The software revision number will briefly display, followed by a screen presenting an option for use of the on-line Help system, as shown below.

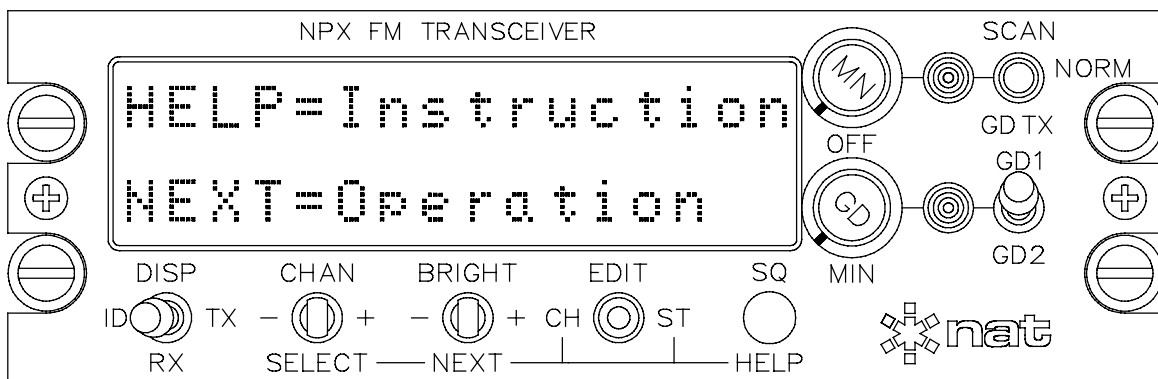

If you push the **HELP** button, the radio will present a tutorial on the operation of the radio. To advance through the tutorial, press **HELP** after reading each screen. To exit this initial **HELP** function at any time, move the **NEXT** switch momentarily left or right.

### 3.2.2 Initial Operating Display

If you decline 'Help' (by using the NEXT switch as directed), the radio will display a summary of the installed functions and current settings (this feature can be disabled at installation for faster start-up). The radio is then ready for normal operation.

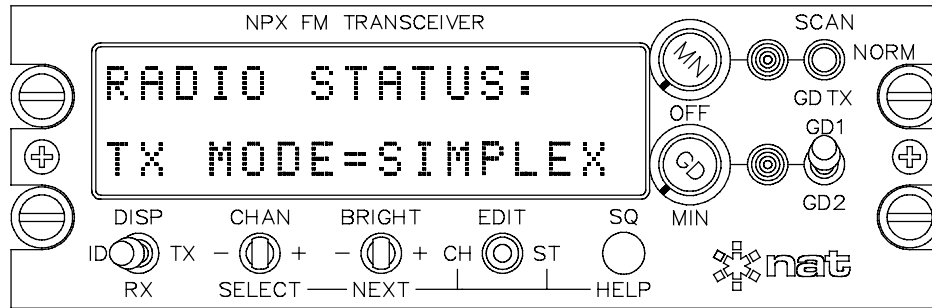

### 3.3 Display

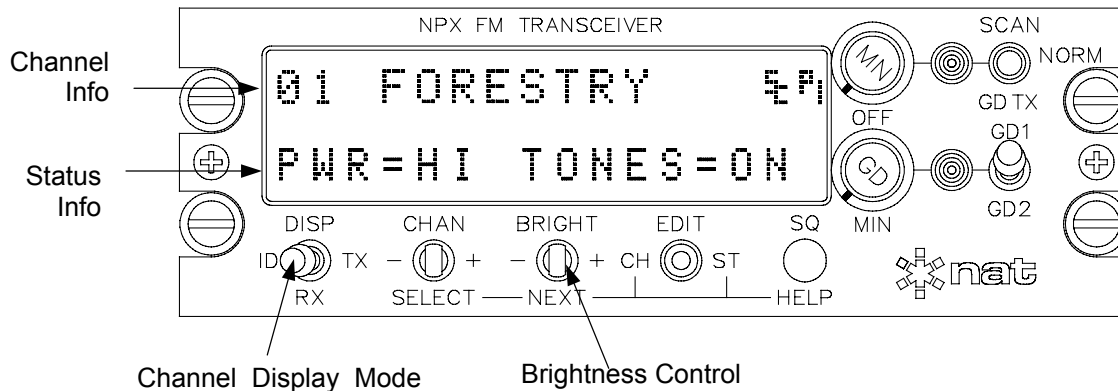

The diagram above shows a typical radio display in 'Normal' operating mode. The upper row of the display contains information related to the currently selected channel. The specific information displayed depends on the setting of the DISPLAY switch located in the bottom left hand corner of the front panel. When it is in the ID position (as shown above), the display shows the channel identifier or name. When it is in the RX or TX position, the display shows the respective receive or transmit information. See section 3.6 for further details on the Channel Display.

The lower row of the display contains information related to specific radio functions. Normally, it shows the settings for the power level and the CTCSS tones. However, entering the Status edit mode allows the display of other function settings. See section 3.8 for further details on displaying and changing Status information.

The BRIGHT switch controls the brightness of the display text. See section 3.5.2 for further details.

### 3.4 Function Controls

The controls located to the right of the display are 'Function' controls. These controls access the radio functions most often used. Access to all other functions is via the status lines (see section 3.8 for further details on 'Status Editing').

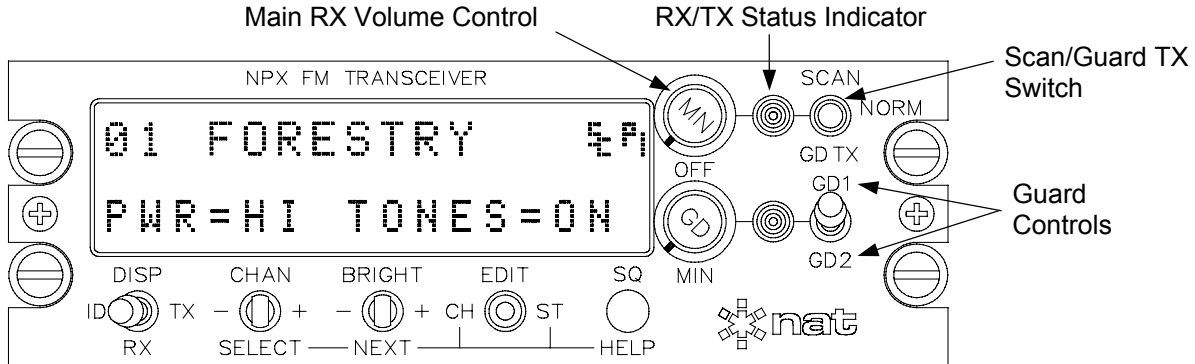

#### 3.4.1 Main RX (Receive) Volume Control

Set this rotary control to the furthest counterclockwise position (past the 'Off' detent) to turn 'off' the radio. Rotating it clockwise will turn 'on' the radio. To increase the volume of the main receiver, turn this knob clockwise; to decrease the volume turn this knob counterclockwise.

#### 3.4.2 RX/TX Status Indicator

Next to the main RX volume control is a bi-color LED indicator that displays the RX (Receive) status of the main receiver and the TX (Transmit) status of the radio. When the radio is transmitting the LED will light green. When the main receiver receives a signal, the LED will light amber. If the radio is idle (not receiving or transmitting), the LED will be dark. The color-coding used for these functions corresponds to standard aircraft FM radio conventions. It is worth noting that this is the reverse of standard vehicular conventions so may confuse some emergency services staff familiar with land mobile equipment.

The receive indicator (amber) informs the operator that the channel is active with radio traffic of some kind. A radio that is receiving may still not produce any audio if the tones present on the receive signal do not match the tones set in the radio. See section 3.9 for further details on how CTCSS tones work.

### 3.4.3 Scan/Guard TX Switch

When this switch is in the SCAN position, the radio will begin scanning. See section 3.10 for further details on scanning.

When this switch is in the GD TX position, all radio transmissions will be on the guard transmit frequency instead of the transmit frequency of the current channel. The radio continues to receive on both the Guard and Main receivers. This function only applies to radios with the guard receiver option installed. If not, the radio will display 'GD NOT INSTALLED' on the upper line when the switch is set to the GD TX position.

Set this switch to the NORM position to disable scanning. All radio transmissions will use the transmit frequency of the current channel.

### 3.4.4 Guard Controls

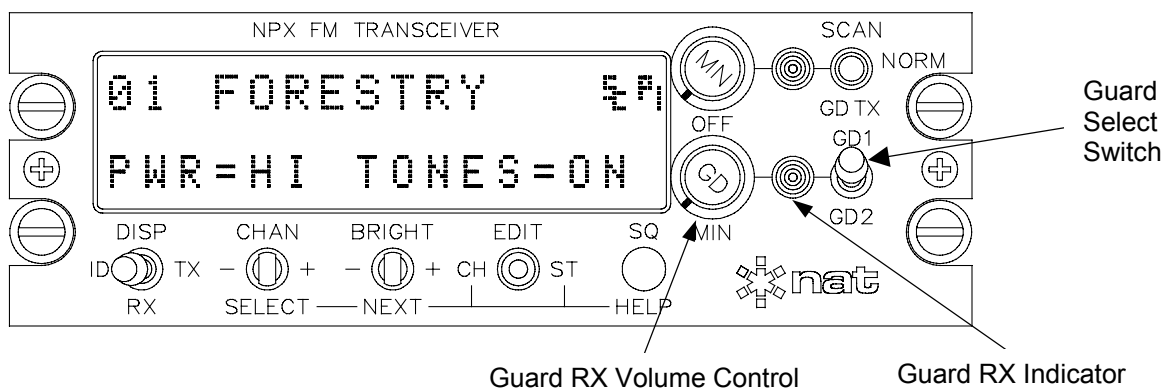

The guard controls are functional only in radios with the optional guard receiver installed.

The rotary knob independently sets the guard RX volume. In most models, there is no 'Off' detent position. On most NPX models, even with the guard RX volume set completely counterclockwise, the operator will still hear activity on the guard channel (at the preset minimum level).

The Guard Select switch (marked GD1/GD2 on the faceplate) selects the active guard channel. For standard guard receiver modules (-x5x), the first guard channel (GD1) has a receive frequency of 168.625 MHz and the second guard channel (GD2) has a receive frequency of 167.950 MHz, as specified by the USFS. Radios with custom guard receiver modules are available (-x6x). For radios with synthesized guard modules (-x7x), the receive frequencies for both the GD1 and GD2 channels are programmable via the front panel or serial load to any frequency in the range of 138.000 to 173.995 MHz in 5.0/6.25 kHz increments. The transmit frequencies of the guard channels are programmable. The Guard RX LED indicator lights amber when there is activity on the selected guard channel.

### 3.5 General Controls — Normal Operating Mode

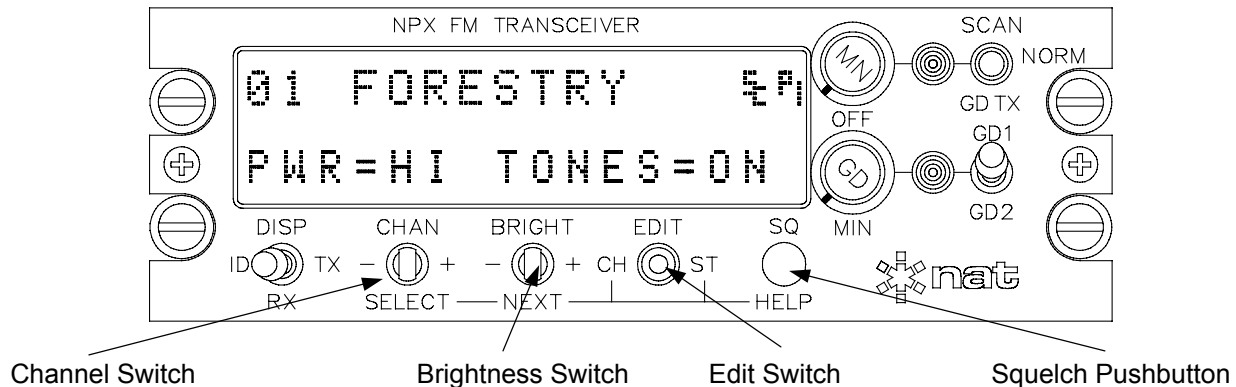

The General Controls are those labeled in the above diagram and affect the over-all operation of the radio. The position of the EDIT switch determines the operating mode of the radio. The other three controls (the two center-off momentary switches and the pushbutton) have dual functions, operating differently depending upon the selected operating mode.

When the EDIT switch is in the center position (as shown), the radio is in 'Normal' operating mode and the functions of the other switches are those of the upper label.

Lock the EDIT switch to either the left (CH) or right (ST) position, to set the radio in one of the two 'EDIT' modes. In both 'EDIT' modes, the functions of the other switches are those of the lower label. Engraved panel lines tie related Edit functions together. See sections 3.7 and 3.8 for further details on editing.

#### 3.5.1 Channel Switch

To scroll to the desired channel use the CHAN switch. Momentarily press it to the right '+' to increment by one channel and to the left '-' to decrement by one channel. Holding the switch in either the left or right position causes the radio to continue to change channels with increasing speed. This allows for quick selection of any channel.

Remote channel selection is possible with the installation of an external switch.

#### 3.5.2 Brightness Switch

The BRIGHT switch controls the brightness of the radio display. Momentarily press it to the right '+' to increment the display brightness by one level and to the left '-' to decrement by one level. There are seven brightness levels from which to select. The radio will retain the display brightness information when turned off, but on power up will limit brightness to a maximum of level five.

### 3.5.3 Squelch Pushbutton

Pressing the squelch test button over-rides all squelch logic, and lets the radio's un-squelched audio receive signal pass to the aircraft's audio system. The squelch test function is useful for monitoring activity on the radio when tones prevent the squelch from opening, or to verify volume settings or radio function.

## 3.6 Channel Display

For each channel stored in the radio, there are three data lines; the ID line, the RX line, and the TX line. Depending on the position of the DISPLAY switch, one of these data lines will be shown on the top row of the display. Regardless of which of the three is being displayed, the channel number will always show on the far left hand side and RX/TX functions will be operational.

### 3.6.1 ID Display Line

The ID line includes the channel number, the channel label or name, the scan list flag, and the priority scan channel flag. A typical ID line might look like this:

01	FORESTRY	sc p1
----	----------	-------

Channel	Label	Scan Flags
---------	-------	------------

The label for each channel is an alphanumeric name that may be up to 10 characters long. The channel name has no effect on radio operation, and is provided for operator convenience in identifying the selected channel.

The scan list flag indicates whether or not the radio monitors the channel during scanning. The 'S' character means that the channel is in the scan list. A dash '-' indicates the channel is not in the scan list. The 'P' character means that the channel is the priority scan channel. A dash '-' indicates the channel is not selected as a priority channel.

If the radio is a NPX138N, there will also be a bandwidth flag displayed on the ID line. A typical NPX138N ID line might look like this:

01	FORESTRY	$\bar{n}$	sc p1
----	----------	-----------	-------

Channel	Label	Bandwidth	Scan Flags
---------	-------	-----------	------------

The bandwidth flag indicates the current modulation acceptance and transmit deviation mode. A ' $\bar{w}$ ' character indicates that the channel is operating in wide-band ( $\pm 5.0$  kHz Rated System Deviation) mode. An ' $\bar{n}$ ' character indicates that the channel is operating in narrow-band ( $\pm 2.5$  kHz Rated System Deviation) mode (refer to section 3.11).

### 3.6.2 RX Display Line

The RX line includes the channel number, the receive frequency and the receive tone. A typical RX line might look like this:

01	156. 8750r	91
----	------------	----

**Channel    RX Freq.    RX Tone**

The radio will receive incoming FM signals that have a carrier frequency equal to that of the receive frequency of the displayed channel.

If the display shows the RX frequency as `***.****`, it means the programmed frequency is invalid. See section 3.7 for details on how to change it to a valid value. The small 'r' indicates that the data displayed is 'Receive' data. If the radio is in 'Simplex' mode, an 's' will replace the 'r'. In 'Simplex' or 'Direct' operation, the radio's TX data matches the RX data. This permits talk-around operation on repeaters. The programmed TX data remains in the radio, but is unused until the operator returns the radio to duplex mode.

The last three positions (far right hand side) on the RX line display an optional CTCSS (sub-audible) tone used for repeater or squelch control. The radio has several different methods by which to display the tone. See section 3.9 for further details on tones.

### 3.6.3 TX Display Line

The TX line includes the channel number, the transmit frequency and the transmit tone. A typical TX line might look like this:

01	156. 8750t	91
----	------------	----

**Channel    TX Freq.    TX Tone**

When you key the microphone the radio will transmit an FM signal that has a carrier frequency equal to that of the transmit frequency of the displayed channel.

If the display shows the TX frequency as `***.****`, it means the programmed frequency is invalid. See section 3.7 for details on how to change it to a valid value. The small 't' indicates that the data displayed is 'Transmit' data. If the radio is in Simplex mode, an 's' will replace the 't'. In 'Simplex' or 'Direct' operation, the radio's TX data matches the RX data. This permits talk-around operation on repeaters. The programmed TX data remains in the radio, but is unused until the operator returns the radio to duplex mode.

The last three positions (far right hand side) on the TX line display an optional CTCSS (sub-audible) tone used for repeater or squelch control. The radio has several different methods by which to display the tone. See section 3.9 for further details on tones.



### 3.7.1 SELECT Switch

The SELECT switch steps the data entry up or down (+/-). The radio only permits a valid choice for each position selected for editing. This is to aid operators in reducing entry mistakes, particularly when busy with other flight procedures.

The selection choices string together as if in a circle, and the operator moves through this circle with the SELECT switch. Depending on which way the operator sets the SELECT switch (+ or -), the editor will move around the circle in either direction.

When editing frequency (TX or RX) the editor removes numbers from this circle that do not apply to the particular cursor position. For example, most NPX138 radios can only have a 3, 4, 5, 6 or 7 in the 10's of MHz position, so the editor does not permit any other numbers during editing from the front panel.

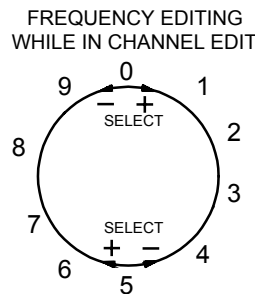

When editing a channel ID label the editor adds the alphabetic characters and frequently used symbols to this circle that apply. For example, the blank (visible as a flashing underline ' \_ ' to show the cursor location), the slash (/) and the number sign (#).

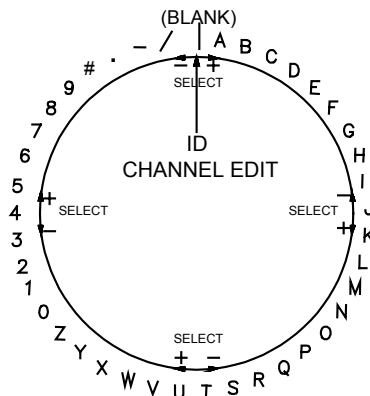

### 3.7.2 NEXT Switch

The NEXT switch moves the editing cursor one position to the right if momentarily set to '+' and one position to the left if momentarily set to '-'. The cursor will wrap around when it reaches either end of the line. The editor will change what choices are valid as the cursor moves from one character to the next.

Sometimes, more than one character will flash. This is because the only valid choices involve multiple characters, such as the fractional kHz entry for a channel frequency. This is also true for tone code entries. The SELECT switch will slew through the available entries from an internal table.

### 3.7.3 EDIT Switch

This locking, center-off switch selects the operating mode of the radio. For NORMAL radio operation set the EDIT switch to the center or 'Off' position. Edited data stores automatically when changed so when editing is complete, the operator need only set the EDIT switch back to 'Off'.

### 3.7.4 HELP Switch

You can access general operation HELP from the initial power-up screen (see section 3.2.1). If you require basic help when the NPX radio is already on, cycle the radio off and then back on again (using the volume control or the external breaker). The option for comprehensive help will re-appear.

## 3.8 Status Editing

There is simply not enough room on the compact front panel of the NPX radio to fit a switch for every radio function. The solution for this is the use of status lines to display and control features that do not require immediate accessibility via the front panel.

As when editing channel data, the display shows only allowable options. This mode can also display the status of the radio quickly, without editing any data. The Status editing process is identical to the channel editing process only the select switch does not change any information.

To edit status line data, pull and lock the EDIT switch to the right (ST).

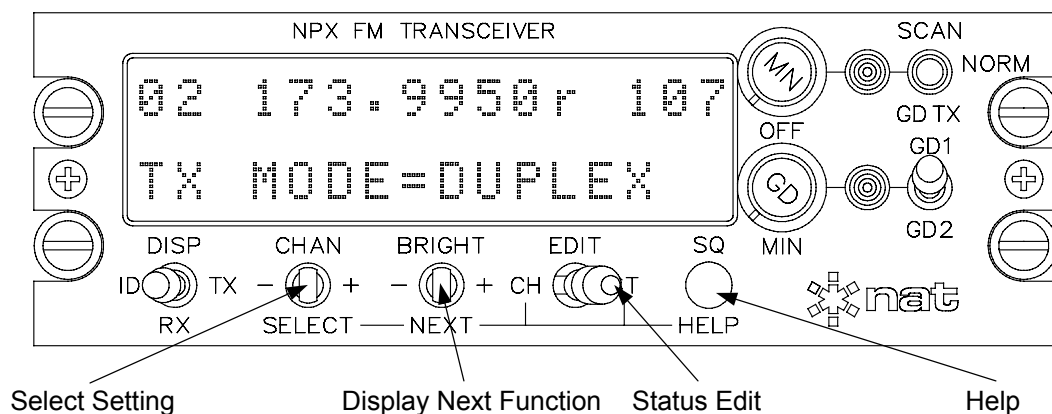

### 3.8.1 NEXT and SELECT Switch Use

---

Toggling SELECT will step to the previous/next available setting for the current function.

To advance to the next function, toggle NEXT. Use the SELECT switch to again choose the desired setting, and continue in this manner until all the radio status lines contain desired information.

When editing is finished, simply return the EDIT switch to 'Off' (center position) to store the information. Exit at any time; it is not necessary to go through the entire status listing.

### 3.8.2 Status Edit Features

---

The STATUS EDIT features currently implemented in NPX138 are as follows:

- TX MODE

There are two modes possible: DUPLEX (repeater) operation, and SIMPLEX (direct) operation. Duplex means that the radio uses both the RX and TX frequencies programmed into the selected channel. Simplex means that the radio uses the RX frequency programmed into the selected channel for both RX and TX purposes. The programmed TX data remains in the radio, but is unused until the operator returns the radio to duplex mode.

- POWER

The NPX radio can transmit at either a HI (10 watt) or LO (1 watt) power setting. Many radio station licenses have power restrictions at altitude, and must be set to low TX power above 5,000 feet for legal operation. This feature also helps prevent repeater interference at altitude and permit secure operations.

- TONES

Radio tones are selectable to ON, OFF, or TX ONLY, thus enabling or disabling any tones set on a per channel basis through channel editing. TX ONLY enables only the transmit tone, but not the receive one. See section 3.9 for further details on tones.

- TONE DISP

The radio permits the user to define the tone presentation to suit local operations. This selection can be for the tone frequency itself (truncated to whole Hz), referred to as FREQ, or it can be one of several codes. The sequential numbers for the EIA tones are 1-38. The alphanumeric Motorola codes are referred to as MCODES. The shifted octal codes used by Wulfsberg are referred to as WCODES. See section 3.9 for further details on tones.

- SCAN

There are three scanning modes available for selection: LIST, PRIORITY, and LIST+PRI. See section 3.10 for further details on scanning.

- P1

This is the Priority channel used in Priority and List+Priority Scanning. It can be set to any valid channel number, or if not required, can be set to NONE. When the SCAN option is selected to LIST, the priority channels are not active but are retained in memory. See section 3.10 for further details on scanning.

- PWR-UP HELP

The display of the HELP screen at power up can be selected on or off.

- PWR-UP CHAN

This is the channel the radio will go to when powered up. The operator can select a specific channel or set this option to PDC (Power-Down Channel). PDC will cause the radio to power up on the last used channel.

## **3.9 Tones**

---

### **3.9.1 General**

---

The tone system used by the NPX radio is a Continuous Tone-Coded Squelch System (CTCSS), as defined by an Electronic Industries Association (EIA) standard. The radio adds these tones to the normal signal modulation (such as voice) to uniquely identify or select a particular radio or group of users.

More commonly, these tones are referred to as sub-audible tones. This is because the filtering action of the radio eliminates them from the received audio. Therefore neither the sending nor receiving party will hear them. These tones are also sometimes referred to as Private Line (PL) tones.

### 3.9.2 Tone Display and Selection

---

The NPX radio displays the tones for the selected channel on the last three positions (far right hand side) of the RX and TX lines. Use the Channel Edit mode to select and store the appropriate tones for each channel. The operator can set different tones for receive and transmit. Select '-' if you do not require a tone.

By editing the TONE DISP status line, the operator can configure the radio to display the tones using one of four different methods. The four tone display modes are:

- Tone Frequency (FREQ):

This is the actual frequency of the tone, measured in Hertz (cycles/second). There are only three digits available on the radio to display this data, so the radio truncates any decimal fraction on the display (i.e. 103.5 Hz becomes 103). Although not displayed, the radio uses the exact frequency.

- EIA Codes (1-38):

This is a number from 1-38 that identifies the tone in sequential order from lowest (67.0 Hz) to highest (250.3 Hz)

- Wulfsberg Codes (WCODES):

These are sequential shifted OCTAL codes based on the thumbwheel design of the Wulfsberg C-1000 control. Because they are missing numbers ending in 0 & 9, they can be confusing, especially to those familiar with the straight sequential number of the EIA codes.

- Motorola Codes (MCODES):

These are alphanumeric codes that often appear in the land mobile business, especially if Motorola equipment is used.

Table 1 below shows the four different display options for each of the available tones.

<b>Tone Frequency (Hz)</b>	<b>1-38</b>	<b>WCODE</b>	<b>MCODE</b>
<b>67.0</b>	1	01	XZ
<b>71.9</b>	2	02	XA
<b>74.4</b>	3	03	WA
<b>77.0</b>	4	04	XB
<b>79.7</b>	5	05	SP
<b>82.5</b>	6	06	YZ
<b>85.4</b>	7	07	YA
<b>88.5</b>	8	08	YB
<b>91.5</b>	9	11	ZZ
<b>94.8</b>	10	12	ZA
<b>97.4</b>	11	13	ZB
<b>100.0</b>	12	14	1Z
<b>103.5</b>	13	15	1A
<b>107.2</b>	14	16	1B
<b>110.9</b>	15	17	2Z
<b>114.8</b>	16	18	2A
<b>118.8</b>	17	21	2B
<b>123.0</b>	18	22	3Z
<b>127.3</b>	19	23	3A
<b>131.8</b>	20	24	3B
<b>136.5</b>	21	25	4Z
<b>141.3</b>	22	26	4A
<b>146.2</b>	23	27	4B
<b>151.4</b>	24	28	5Z
<b>156.7</b>	25	31	5A
<b>162.2</b>	26	32	5B
<b>167.9</b>	27	33	6Z
<b>173.8</b>	28	34	6A
<b>179.9</b>	29	35	6B
<b>186.2</b>	30	36	7Z
<b>192.8</b>	31	37	7A
<b>203.5</b>	32	38	M1
<b>210.7</b>	33	41	M2
<b>218.1</b>	34	42	M3
<b>225.7</b>	35	43	M4
<b>233.6</b>	36	44	M5
<b>241.8</b>	37	45	M6
<b>250.3</b>	38	46	M7

Display Options - Table 1

### 3.9.3 Turning Tones On and Off

---

The NPX radio also has the capability to have tones enabled or disabled globally. By editing the TONES status line, the operator can set all the tones ON, OFF or to TX ONLY.

TONES=ON enables all the tones programmed into the individual channels. (Remember that some channels may have no tones programmed.) Both the frequency and tone of incoming signals must be correct to hear the receive audio. If the incoming frequency is correct, but the incoming tone does not match the tone set in the radio, the radio will not produce any audio. The RX indicator lights whether the logic is correct for audio or not, to warn the operator that the channel is active with radio traffic of some kind.

TONES=OFF disables all tones. The radio will still display the individual tones on the RX and TX channel display lines, but only for reference purposes. All incoming transmissions on the RX frequency will be heard.

TONES=TX ONLY enables all transmit tones but disables all receive tones. This is used on U.S. Forest Service contracts, for example, where the tones are needed only to open the repeater and serve no RX squelch function.

## 3.10 Scanning

---

### 3.10.1 General

---

Scanning is an automatic internal function that rapidly samples a selected group of channels. It is very useful for checking radio traffic on one or more channels, while still working a 'home' or monitor channel.

When scanning is active, the radio ignores all CTCSS/Sub-audible Tones. It does not test for these conditions when determining whether or not to lock on to a channel (although tones do remain active for squelch control). This is because the delay to test for tones is so long (compared to the channel lock-up time), that it would seriously compromise scanning. It takes almost half a second to provide tone decoding, which would result in virtually useless scanning of 2 channels/second. The radio will stop on any flagged channel that has a correct RF signal present, but there may be no audible signal if the tones do not match those set in the radio. To avoid any confusion, set tones to OFF (via the status edit mode) during scanning so that you will hear all channels.

In order to be detected properly, a signal needs to be slightly stronger when the radio is scanning than when the radio is in 'Normal' operating mode.

### 3.10.2 Scan Operation

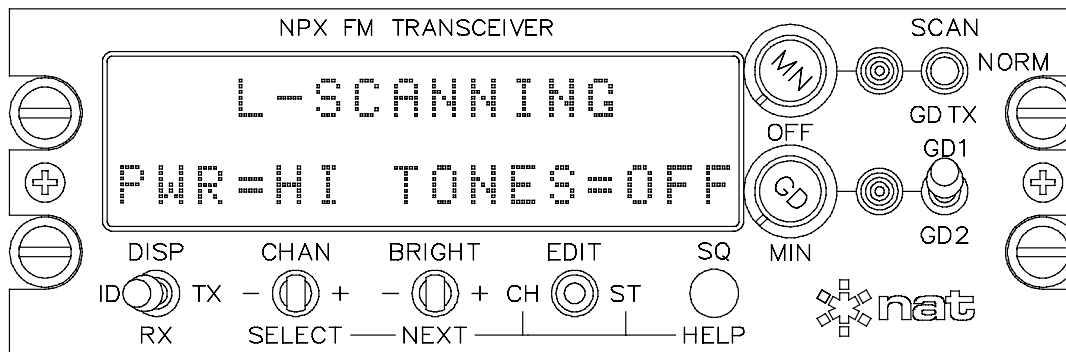

Activate scanning by moving the SCAN/NORM/GUARD TX toggle switch to the SCAN position. The 'home' channel is the channel that the radio was on before scanning was activated.

The radio scans the home channel and all channels on the 'scan list' at a maximum rate of 30 channels/second.

When the radio is actively scanning, a SCANNING message will appear on the upper row of the display. When the radio has found and locked onto an active channel, the display will show the correct channel data corresponding to the display mode selected (ID, RX or TX).

If the operator keys the transceiver while the radio is actively scanning, the radio will be re-channeled to the 'home' channel for transmission. If the radio is locked onto a channel, transmission will occur on that channel.

From the SCAN status line, the operator may select one of several pre-defined modes that control how the radio will carry out the scanning function. They are described in the following section.

### 3.10.3 Scan Modes

You can designate any NPX channel as a PRIORITY channel and/or a LIST channel. The appropriate scan flags will appear after the channel name on the ID line (P1 and/or S<sub>c</sub>). Any or all of the channels can be in the scan list for LIST SCANNING, but only one channel can have the Priority designation.

Use the status edit mode to select both the priority channel and the SCAN MODE. Use the channel edit mode to tag channels for list scanning. The three scan modes are as follows:

- LIST Scanning

The second last space on each channel ID line indicates whether that channel is in the scan list or not. If it displays a dash '-', the channel is not in the list. If the channel is in the list it displays the scan flag (Sc). Use the channel edit mode to change the scan list status for each channel. You may place any number of channels in the scan list; but for effective scanning operation, you should keep the number to a minimum.

Once scanning is activated (using the front panel SCAN switch), the radio will move through all the flagged channels in consecutive order until it detects a carrier. It will remain on that channel until traffic stops, then wait for a 2-3 second latency period to permit the operator to reply. If there is no further activity, the radio will continue through the list, and then start over. When scanning is turned off, the radio resumes normal operation on the home channel (the one set before scanning began).

During List scanning, the operator can use the front panel CHAN switch to delete 'nuisance' channels. If the radio locks onto a channel, and the operator does not want to monitor that channel, he may move the CHAN switch to the left '-' to temporarily delete that channel from the scan list. That channel will remain out of the scan list until the operator disables the scan mode (either by moving the scan switch back to NORM or by turning off the radio).

- PRIORITY Scanning

The radio scans the home channel plus one priority channel. It will continue scanning the priority channel if it finds an active channel.

To avoid accidental duplication, use the Status Edit mode to set the priority channel. 'P1' designates the priority channel; the lowest priority is the home channel. The 'P1' flag will appear on the last space of the ID line of the appropriate channel.

If the radio receives a transmission on the home channel, it will continue to check 'P1'. The check during priority scan is very fast, about every 1/3 second, and will sound like a faint tick when occurring during other reception. If there is activity on the designated 'P1' channel, the radio will re-channel to that frequency, regardless of activity on other channels.

The radio will return to the home channel 2-3 seconds after activity on the priority channel has ceased.

- LIST+PRIORITY Scanning

In this mode, both LIST and PRIORITY features are combined, so that the radio checks 'list' while still periodically testing for activity on the priority channel. In this case, list channels have a lower priority than the home channel, and are scanned only when there is no activity on the other two.

### 3.11 Wideband/Narrowband Operation

---

The NPX138N is capable of operating in either a wideband mode ( $\pm 5.0$  kHz Rated System Deviation) or narrowband mode ( $\pm 2.5$  kHz Rated System Deviation).

#### 3.11.1 Editing Wideband/Narrowband Flag

---

To edit the Wideband/Narrowband channel characteristic, place the 'DISP' switch to the ID position and place the radio into channel edit mode. Use the NEXT switch to place the EDIT CURSOR in the correct display position, marked by the current flag setting (Note: the character should be flashing). To change this selection use the '+' or '-' SELECT switch. The channel data will save automatically when you exit 'Edit' mode.

The ID line displays a 'W' character when the radio is in 'Wideband' mode. The ID line displays an 'N' when the radio is in 'Narrowband' mode (refer to section 3.6.1).

### 3.12 Configuration Mode

---

This mode of operation is not required for normal operation and is intended to aid in servicing and radio set-up. Various firmware functions of the radio can be set via this mode. Entering this mode requires a special code and switch sequence, and should be USED ONLY AT THE FACTORY OR BY QUALIFIED SERVICE PERSONNEL.

#### 3.12.1 Using Configuration Mode

---

**WARNING!**  
**Incorrect Use Of This Mode May Render The Radio INOPERABLE!**  
**Use This Function With Extreme Care.**

**If you have ANY questions, please phone NAT prior to use.**

To enter this mode, do the following, **EXACTLY AS DESCRIBED**:

- a) With the power turned off, lock the **EDIT** switch into the **CH** position.
- b) Turn on the radio. The 'Lock EDIT switch OFF for Norm OP' message should appear.
- c) Press the **HELP** button. The '...PASSWORD:' message should appear.
- d) Although there is no cursor on the screen, use the **SELECT** and **NEXT** controls to enter the configuration mode password, which is **IAC**. Be sure to use the **NEXT** switch after entering the last character. The 'Config Mode...' screen should appear.

- e) Depending on the style of radio and the options selected, the information on this and subsequent screens will vary. Don't worry if all the features listed in the following table are not displayed.
- f) Using the normal editing procedure (**SELECT/NEXT**), select a valid option for each feature presented.
- g) **It is up to you** to ensure that the options you select are compatible with each other, and with the hardware being used. If they are not, the radio may not operate correctly. Read the following table carefully to ensure that you understand the configuration options completely.

### 3.12.2 Configuration Option Table

FEATURE	VALID OPTIONS	COMMENTS
STATUS DISPLAY ON POWER-UP	ON, OFF	Determines whether or not the radio status lines are displayed on power-up.
EXT. DATA PAD	ON, OFF	Determines whether or not the radio will accept data from an external data entry pad.
LOWEST FREQ.	138, 150	Sets the lower limit (in MHz) for frequency editing. All NPX138 radios can be selected to either option.
CHANS. INST.	20, 40, 60, 80, 100	The number of channels available in the radio. Does NOT include guard channels.
TX TIME OUT	000, 030, 060, 090, ... 240	The time, in seconds, the Transmitter is allowed to be active for one continuous period. Intended to prevent 'stuck mic' conditions from damaging the equipment.
GD RX EDIT (-x7x models only)	ON, OFF	Determines whether or not the guard channels are editable from the front panel.

Configuration Options - Table 2

End of Section 3.0