

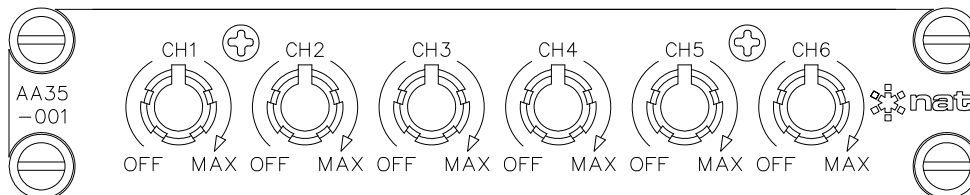

Installation and Operation Manual

AA35-001 Audio Mixer Panel



SM25

ISSUE 4.01

Northern Airborne Technology Ltd.
1925 Kirschner Road
Kelowna, BC, Canada.
V1Y 4N7
Telephone (250) 763-2232
Facsimile (250) 762-3374

Issued on the authority of Northern Airborne Technology Ltd.

Copyright 2003



AA35-001 Audio Mixer Panel
SM25 Installation and Operation Manual

Table of Contents

Section	Title	Page
1.	Description	
1.1	Introduction	1-1
1.2	Product Description	1-1
1.3	Design Features	1-1
1.4	Specifications	1-1
1.4.1	Electrical Specifications	1-1
1.4.2	Physical Specifications	1-2
1.4.3	Environmental Specifications	1-2
1.5	Unit Nomenclature	1-3
2.	Installation	
2.1	Introduction	2-1
2.2	Unpacking and Inspection	2-1
2.2.1	Warranty	2-1
2.3	Continued Airworthiness	2-1
2.4	Installation Procedures	2-1
2.4.1	Warnings	2-1
2.4.2	Cautions	2-2
2.4.3	Cabling and Wiring	2-2
2.4.4	Post Installation Checks	2-2
2.5	Adjustments and Connections	2-3
2.5.1	8/600 Ω Adjustment	2-3
2.5.2	Input Audio Level Adjustment	2-3
2.5.3	Composite Output Level Adjustment	2-3
2.6	Accessories Required But Not Supplied	2-4
2.7	Installation Drawings	2-4
3.	Operation	
3.1	Introduction	3-1
3.2	General Information	3-1
3.3	Controls and Indicators	3-1
3.3.1	Channel Controls	3-1



AA35-001 Audio Mixer Panel SM25 Installation and Operation Manual

Section 1 Description

1.1 Introduction

Information in this section consists of product description, design features and specifications for the AA35-001 Audio Mixer Panel. All derivative product information shall be contained in the applicable manual supplement, which may be obtained from NAT as required.

Review all notes, warnings and cautions.

1.2 Product Description

The AA35-001 Audio Mixer Panel is a six channel summing amplifier with independent level control for each input. It can be used as an expansion panel for existing audio controllers.

The AA35 is also available in remote mount configurations (see Section 1.5)

1.3 Design Features

The AA35-001 Audio Mixer Panel provides six independent channels with differential inputs and balanced outputs for high common mode noise rejection. Also provided is a composite output. Each channel is individually adjustable with a 40 dB range. The input audio level is internally selectable by DIP switch to 2.5 or 7 Vrms. Output impedance of each channel is individually selectable via internal jumpers to allow the connection of an 8 or 600 Ω load.

1.4 Specifications

1.4.1 Electrical Specifications

Input Voltage	27.5 Vdc (nominal)
Input Current	275 mA (nominal)
Lighting	80 mA @ 27.5 Vdc

Input Signals

Channels	6 independent channels
Impedance	4.0 k Ω +/- 10%
Audio level	2.5 or 7 Vrms. Selectable by DIP switch
Circuitry Type:	Differential input for high common mode noise rejection.
Coupling:	<-40 dB input to input Crosstalk



AA35-001 Audio Mixer Panel SM25 Installation and Operation Manual

Output Signals

Channels	6 independent channels plus 1 composite output
Rated level	7.7 Vrms or 100 mW into 600 Ω 1.3 Vrms or 200 mW into 8 Ω
Impedance	20 Ω max
Frequency Response	<3 dB from 350 to 6000 Hz
Distortion	<10% THD @ Rated power output
Circuitry Type:	Balanced output for high common mode noise rejection.
Coupling:	<-50 dB input to output Crosstalk.
Audio Noise Level Without Signal:	>60 dB down from rated output level.
Output Regulation at 400% and 75% of rated load.:	<10% distortion / Δ 3 dB max. of rated output power.

1.4.2 Physical Specifications

Height	1.12" (28.4 mm)
Depth	5.68" (144.27 mm) overall 4.78" (121.14 mm) behind panel
Width (max)	5.75" (146.05 mm) (faceplate)
Width (box)	4.90" (124.46 mm) (behind panel)
Weight	1.1 lb (500 g)
Mounting	Dzus Rail
Faceplate	Laser etched acrylic back-lit panel
Material/Finish	Chassis and cover 5052-H32 brushed aluminum with chromate conversion finish

1.4.3 Environmental Specifications

Temperature:	
Operating	-45° C to +70° C
Survival	-55° C to +85° C
Altitude	35,000 ft. max
Humidity	95%
Vibration/Shock	DO-160C, Cat. N/B/M



AA35-001 Audio Mixer Panel SM25 Installation and Operation Manual

1.5 Unit Nomenclature

These products are included for reference only. For more detailed information on these and other AA35 products, contact the Product Support Department at NAT Ltd.

- AA35-001** Dzus mount audio mixer / summing amplifier panel
Provides signal combinations of up to six in / six out or six in / one composite out
2.5 Vrms or 7 Vrms input level
Output 7.7 Vrms or 100 mW/600 Ohm Max
Panel Lighting 28 Vdc (normal)
- AA35-100** Remote mount audio mixer / summing amplifier
Provides signal combinations of up to six in / six out or six in / one composite out
2.5 Vrms or 7 Vrms input level
Output 7.7 Vrms or 100 mW/600 Ohm Max
- AA35-400** Remote mount audio mixer / summing amplifier for TAWS applications
Provides signal combinations of up to three in / three out or three in / one composite out
2.5 Vrms or 7 Vrms input level
Output 7.7 Vrms or 100 mW/600 Ohm Max

Section 1 ends



AA35-001 Audio Mixer Panel SM25 Installation and Operation Manual

Section 2 Installation

2.1 Introduction

Information in this section consists of unpacking and inspection procedures, installation procedures, post-installation checks and installation drawings for the AA35-001 Audio Mixer Panel.

Review all notes, warnings and cautions.

2.2 Unpacking and Inspection

Unpack the equipment carefully and locate the warranty card. Inspect the unit visually for damage due to shipping and report all such claims immediately to the carrier involved. Check that all items listed below are present before proceeding and report any shortage immediately to your supplier:

- Warranty Card
- Operators Manual
- Certificate of Conformity or Release Certification

2.2.1 Warranty

All Northern Airborne Technology Ltd. products are warranted for 2 years from date of installation by an authorized NAT dealer, to be free of defects in workmanship or performance. This warranty covers all materials and labour, but is exclusive of any transport to deliver the defective unit to and from NAT or its designated warranty repair center, or any labour to remove or re-install the defective unit in the aircraft. Contact NAT for any questions regarding this warranty, its applicability to your units and/or for return authorization. NAT is the final arbitrator concerning warranty administration. Units which have been physically damaged, burned, immersed in water or otherwise abused beyond the scope of normal use will not be considered for warranty. **WARRANTY IS VOID UNLESS THE PRODUCT IS INSTALLED BY AN AUTHORIZED NAT DEALER.** Product for which a warranty card is not returned shall be warranted from date of manufacture.

2.3 Continued Airworthiness

Maintenance of the AA35-001 Audio Mixer Panel is 'on condition' only. Periodic maintenance of this product is not required.

2.4 Installation Procedures

2.4.1 Warnings

<p style="text-align: center;"><u>WARNING:</u> High volume settings can cause hearing damage. Set the headset volume control to the minimum volume setting prior to conducting tests, and slowly increase the headset volume to a comfortable listening level.</p>



AA35-001 Audio Mixer Panel SM25 Installation and Operation Manual

2.4.2 Cautions

CAUTION:

Do not bundle any lines from this unit with transmitter coax feedlines. Do not bundle any logic, audio, or DC power lines from this unit with 400 Hz synchro wiring or AC power lines. Do not position this unit next to any device with a strong alternating magnetic field such as an inverter, motor or blower, or significant audio interference will result.

In all installations, use shielded cable exactly as shown, and ground only as indicated. Significant problems may result from not following these guidelines.

2.4.3 Cabling and Wiring

All wire shall be selected in accordance with the original aircraft manufacturer's Maintenance Instructions or AC43.13-1B Change 1, Paragraphs 11-76 through 11-78. Unshielded wire types shall qualify to MIL-W-22759 as specified in AC43.13-1B Change 1, Paragraphs 11-85, 11-86, and listed in Table 11-11. For shielded wire applications, use Tefzel MIL-C-27500 shielded wire with solder sleeves (for shield terminations) to make the most compact and easily terminated interconnect. Follow the connector map in Section 2.7 as required.

Allow 3" from the end of the shielded wiring to the shield termination to allow the connector hood to be easily installed. Reference the interconnect drawing in Section 2.7 for shield termination details. Note that the hood is a "clamshell" hood, and is installed after the wiring is complete. Aircraft harnessing shall permit the unit to be removed from the panel for easy access to all side adjustments. Do NOT mount the unit until all adjustments have been performed.

Maintain wire segregation and route wiring in accordance with the original aircraft manufacturers Maintenance Instructions.

Unless otherwise noted, all wiring shall be a minimum of 22 AWG, except power and ground lines, which shall be a minimum of 20 AWG. Refer to the Interconnect drawing for additional specifications. Check that the ground connection is clean and well secured, and that it shares no path with any electrically noisy aircraft accessories such as blowers, turn and bank instruments or similar loads. Power to this unit must be supplied from a separate circuit breaker or fuse (fast blow), and not attached to any other circuit breaker without additional protection. Verify that the selected circuit breaker size and wire gauge are adequate for the installation using the techniques specified in AC43.13-1B Change 1, Paragraphs 11-47 through 11-51 and 11-66 through 11-69.

2.4.4 Post Installation Checks

2.4.4.1 Voltage/Resistance Checks

Do not attach the AA35-001 until the following conditions are met.

Check the following:

- a) J1 pins <1> and <2> for +28 Vdc relative to ground.
- b) J1 pins <20> and <21> for continuity to ground (below 0.5Ω).



AA35-001 Audio Mixer Panel SM25 Installation and Operation Manual

2.4.4.2 Power On Checks

Power up the aircraft's systems and confirm normal operation of all functions of the AA35-001. Refer to Section 3 (Operation) for specific operational details.

- a) Check for the correct audio output on each channel.

Upon satisfactory completion of all performance checks, make all required log book entries, electrical load, weight and balance amendments and other documentation as required by your local regulatory agency before releasing the aircraft for service.

2.5 Adjustments and Connections

WARNING:
These procedures should be performed by a qualified service technician, at an ESD safe workstation only. Failure to adhere to this warning could cause injury to personnel and/or damage to equipment.

2.5.1 8/600 Ω Adjustment

Remove the cover from the AA35 and locate the seven 8/600 Ω adjustment jumpers (JP1 thru JP7). Each jumper controls one of the six independent channels or the Composite Output (refer to table 1). When the jumper is connected across pins A and B, the channel is set to operate with an 8 Ω load connected. When connected across B and C (the default setting), the channel is set to operate with a 600 Ω load connected. Refer to the Maintenance Section of this Manual for complete details.

Jumper	Channel
JP1	Channel 1
JP2	Channel 2
JP3	Channel 3
JP4	Channel 4
JP5	Channel 5
JP6	Channel 6
JP7	Composite Output

Table 1: 8/600 Ω Jumpers

2.5.2 Input Audio Level Adjustment

The input audio level adjustment consists of six DIP switches (S1 thru S6), accessible from the right hand side of the AA35. Each switch controls one of the six independent channels. The switch number reflects the channel being controlled (e.g. S1 controls channel 1 and S4 controls channel 4). Each level can be set to allow a 2.5 V (switch up) or a 7.5 V (switch down) input.

2.5.3 Composite Output Level Adjustment

The output level of the composite audio can be adjusted from the right hand side of the AA35. Rotating the trim potentiometer from fully counter clockwise to clockwise will increase the output over a 40 dB range.



**AA35-001 Audio Mixer Panel
SM25 Installation and Operation Manual**

2.6 Accessories Required But Not Supplied

A crimp installation kit p/n AA35-IKC-1 (NAT Part No. D37SV-IKC) is required to complete the installation. The kit consists of the following:

D37SV-IKC

Quantity	Description	NAT Part #
1	D-min 37 Socket Housing	20-21-037
37	MS Crimp Socket	20-26-901
1	37 Pin JVL Hood/Locklever	20-29-370

2.7 Installation Drawings

DOCUMENT	REV.	DESCRIPTION	TYPE	SERIAL NO.
AA35-001				
AA35\001\403-0	1.00	Audio Mixer Panel	Interconnect	All
AA35\001\405-0	1.00	Audio Mixer Panel	Connector Map	All
AA35\001\905-0	1.00	Audio Mixer Panel	Faceplate	Up to 1186
AA35\001\905-0	1.10	Audio Mixer Panel	Faceplate	1187 and up
AA35\001\922-0	1.00	Audio Mixer Panel	Mech. Installation	Up to 1186
AA35\001\922-0	1.10	Audio Mixer Panel	Mech. Installation	1187 and up

Section 2 ends following the above documents

AA35-001

J101

DC-37S
P101 MATING CONNECTOR

EXTERNAL
CONNECTIONS

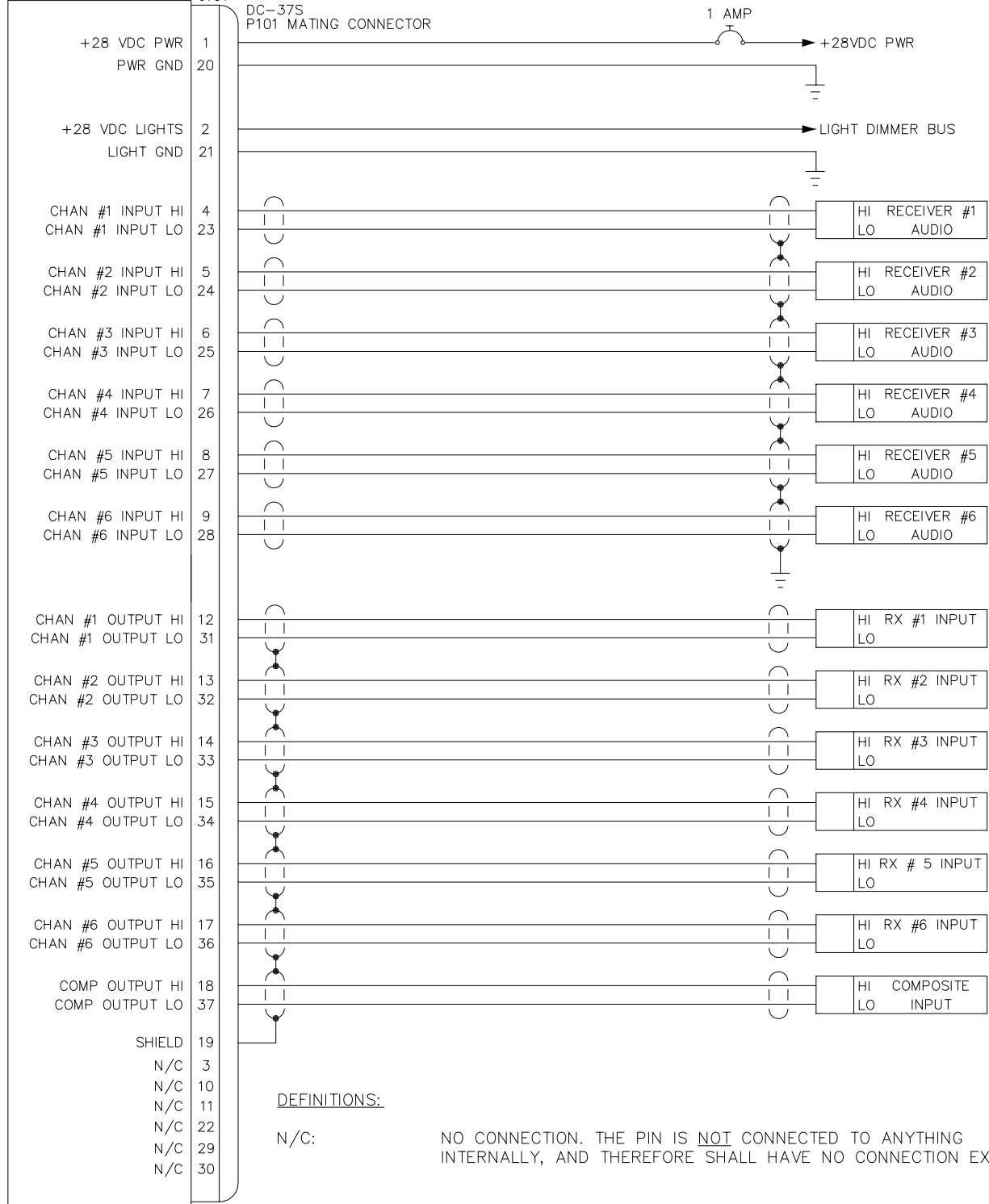

DEFINITIONS:

N/C: NO CONNECTION. THE PIN IS NOT CONNECTED TO ANYTHING INTERNALLY, AND THEREFORE SHALL HAVE NO CONNECTION EXTERNALLY.

Confidential and Proprietary to NAT

DESIGNED	KV	NAT NORTHERN AIRBORNE TECHNOLOGY LTD.				
DRAWN	MWS					
DATE	APR 10/96	TITLE AUDIO MIXER PANEL				
CHECKED	NAT 200					
APPROVED	NAT 107	SIZE A	CAGE CODE 3AB01	PART NO. AA35-001	REV. 1.00	SHEET 1/1
FILE	403-0100.DWG	DWG. TYPE	INTERCONNECT	DWG. NO.	AA35\001\403-0	

P101
 37 PIN FEMALE D-MIN
 MATING CONNECTOR

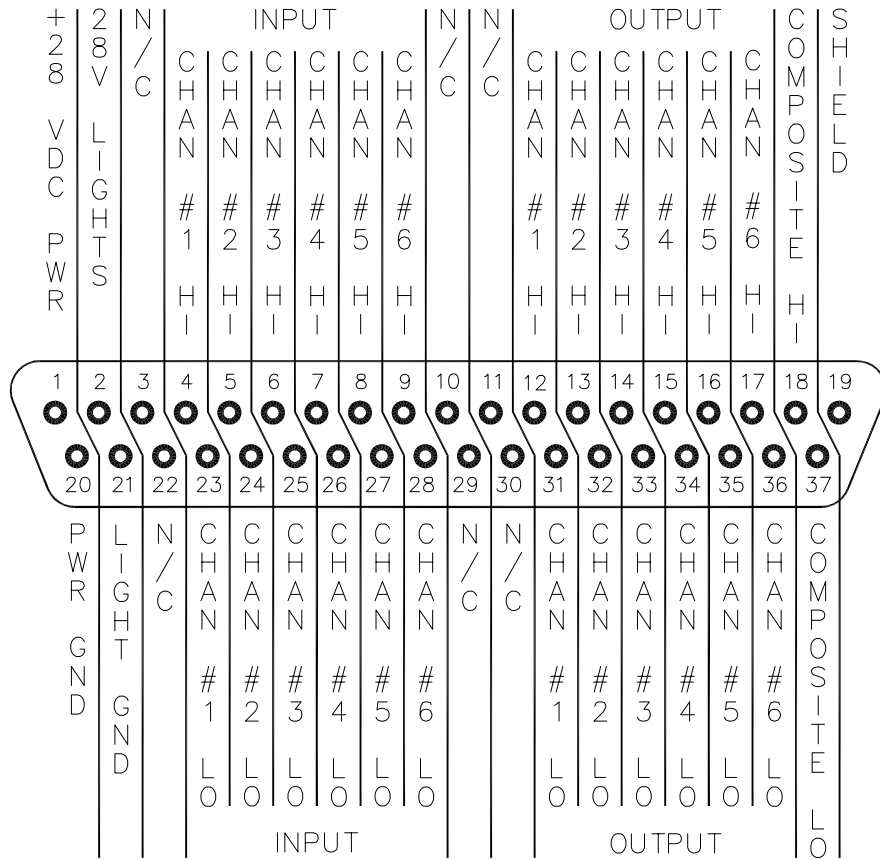

VIEW IS FROM REAR OF AIRFRAME CONNECTOR

Confidential and Proprietary to NAT

DESIGNED	KV	 NAT NORTHERN AIRBORNE TECHNOLOGY LTD.				
DRAWN	MWS					
DATE	APR 9/96	TITLE AUDIO MIXER PANEL				
CHECKED	NAT 200					
APPROVED	NAT 107	SIZE A	CAGE CODE 3AB01	PART NO. AA35-001	REV. 1.00	SHEET 1/1
FILE	405-0100.DWG	DWG. TYPE	CONNECTOR MAP	DWG. NO.	AA35\001\405-0	

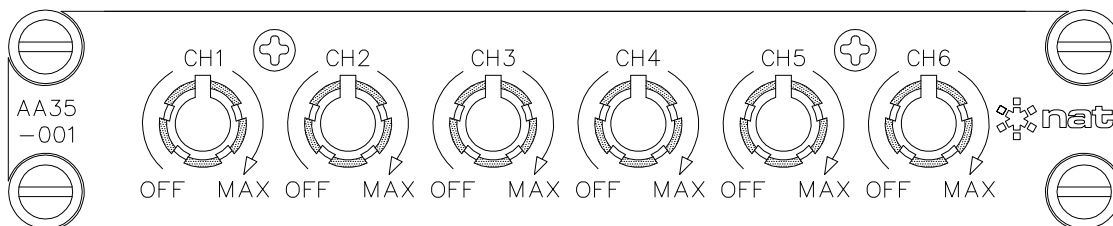

Confidential and Proprietary to NAT

DESIGNED	KV	 NORTHERN AIRBORNE TECHNOLOGY LTD.				
DRAWN	MWS					
DATE	APR 10/96	TITLE AUDIO MIXER PANEL				
CHECKED	NAT 200					
APPROVED	NAT 107	SIZE A	CAGE CODE 3AB01	PART NO. AA35-001	REV. 1.00	SHEET 1/1
FILE	905-0100.DWG	DWG. TYPE FACEPLATE		DWG. NO. AA35\001\905-0		

REVISIONS			
REV	DESCRIPTION	DATE	BY
1.10	ADDED 2 MORE SCREWS TO FACEPLATE	JUL 10/96	MWS

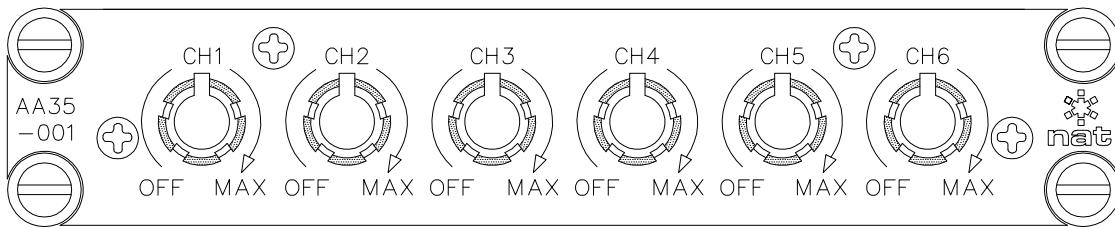

Confidential and Proprietary to NAT

DESIGNED	KV	NORTHERN AIRBORNE TECHNOLOGY LTD.				
DRAWN	MWS					
DATE	APR 10/96	TITLE AUDIO MIXER PANEL				
CHECKED	NAT 200					
APPROVED	NAT 107	SIZE A	CAGE CODE 3AB01	PART NO. AA35-001	REV. 1.10	SHEET 1/1
FILE	905-0110.DWG	DWG. TYPE FACEPLATE		DWG. NO. AA35\001\905-0		

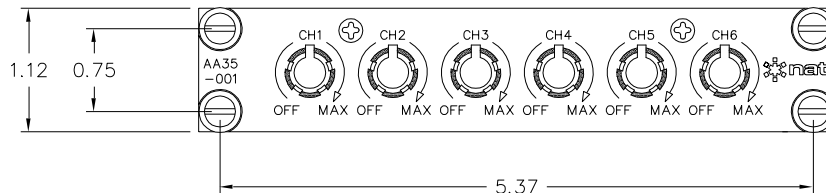
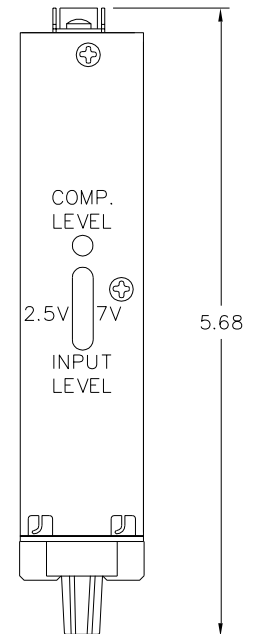
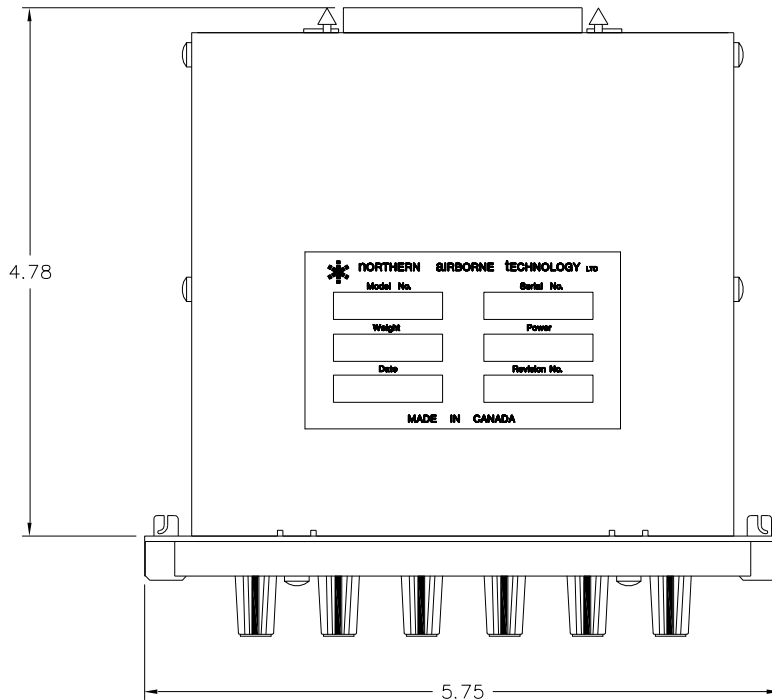
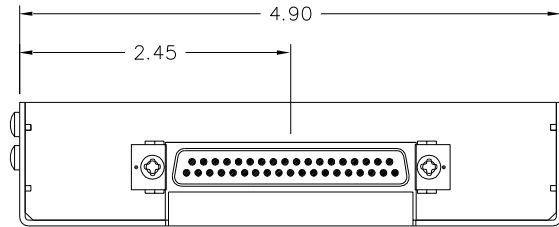



Confidential and Proprietary to NAT

TOLERANCES UNLESS STATED OTHERWISE 0.X=+/-0.030 0.XX=+/-0.010 0.XXX=+/-0.005 0.XXXX=+/-0.002 ANGLE=+/- 0.5 DEG.	DIMENSIONS IN INCHES THIRD ANGLE PROJECTION	DESIGNED KV DRAWN MWS DATE MAR 29/96	NORTHERN AIRBORNE TECHNOLOGY LTD.			
		CHECKED NAT 200	TITLE AUDIO MIXER PANEL			
MATERIAL	APPROVED NAT 107	SIZE A	CAGE CODE 3AB01	PART NO. AA35-001	REV. 1.00	SHEET 1/1
FINISH	FILE 922-0100.DWG	DWG. TYPE MECH. INSTALLATION		DWG. NO. AA35\001\922-0		

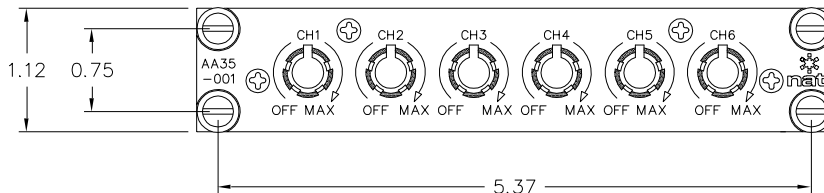
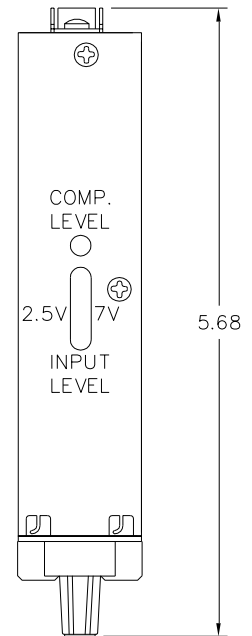
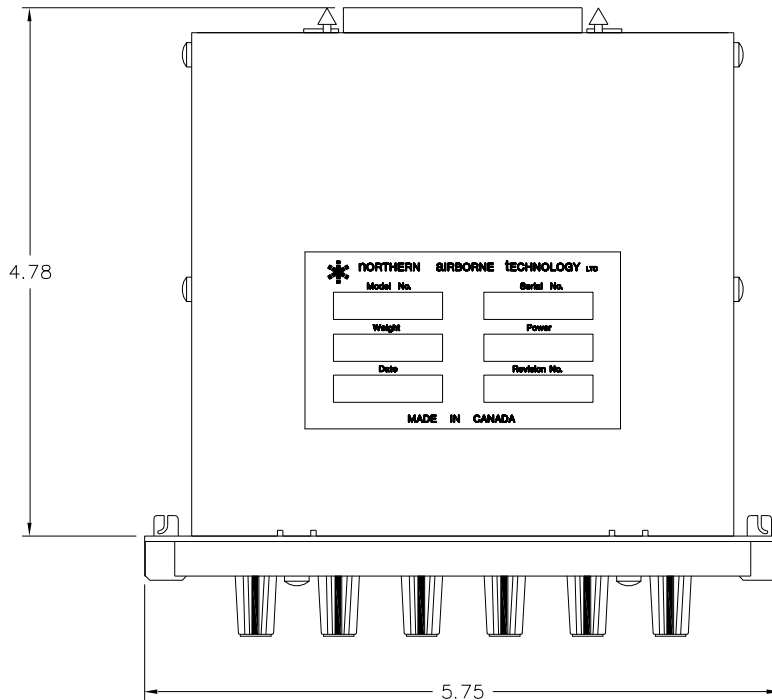
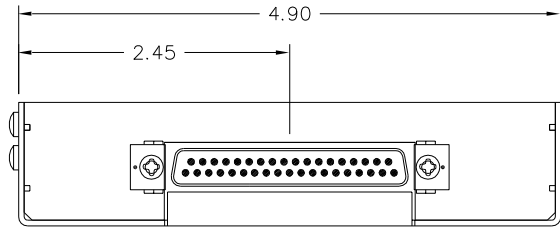
REVISIONS			
REV	DESCRIPTION	DATE	BY
1.10	BOTTOM SCREWS ADDED TO FACEPLATE	JUL 10/96	SWT

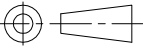

Confidential and Proprietary to NAT

TOLERANCES UNLESS STATED OTHERWISE 0.X=+/-0.030 0.XX=+/-0.010 0.XXX=+/-0.005 0.XXXX=+/-0.002 ANGLE=+/- 0.5 DEG.	DIMENSIONS IN INCHES	DESIGNED	KV	 NAT NORTHERN AIRBORNE TECHNOLOGY LTD.									
	THIRD ANGLE PROJECTION	DRAWN	MWS										
		DATE	MAR 29/96	TITLE AUDIO MIXER PANEL									
		CHECKED	NAT PROD. 130										
MATERIAL		APPROVED		SIZE	A	CAGE CODE	3AB01	PART NO.	AA35-001	REV.	1.10	SHEET	1/1
FINISH		FILE	922-0110.DWG	DWG. TYPE	MECH. INSTALLATION	DWG. NO.	AA35\001\922-0						



AA35-001 Audio Mixer Panel SM25 Installation and Operation Manual

Section 3 Operation

3.1 Introduction

Information in this section consists of the functional and operational procedures for the AA35-001 Audio Mixer Panel.

3.2 General Information

The AA35-001 Audio Mixer Panel is a six channel summing amplifier with independent level control for each input. It can be used as an expansion panel for existing audio controllers.

The AA35-001 Audio Mixer Panel provides six independent channels with differential inputs and balanced outputs for high common mode noise rejection. Also provided is a composite output. Each channel is individually adjustable with a 40 dB range. The input audio level is internally selectable by DIP switch to 2.5 or 7 Vrms. Output impedance of each channel is individually selectable via internal jumpers to allow the connection of an 8 or 600 Ω load.

3.3 Controls and Indicators

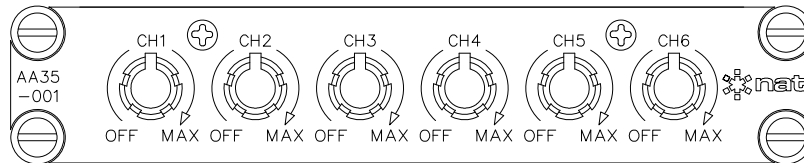

3.3.1 Channel Controls

The AA35-001 has six front panel rotary controls. Each one controls the volume level of an independent channel. With the control fully counterclockwise it is in the OFF detent position and no audio will be heard on the headset for that channel. Rotating the control clockwise past the detent will turn the channel on. The volume will increase as the control is rotated clockwise and decrease as it is rotated counterclockwise.

WARNING:
High volume settings can cause hearing damage.
Set the headset volume control to the minimum volume setting, and slowly increase the headset volume to a comfortable listening level.

Section 3 ends