

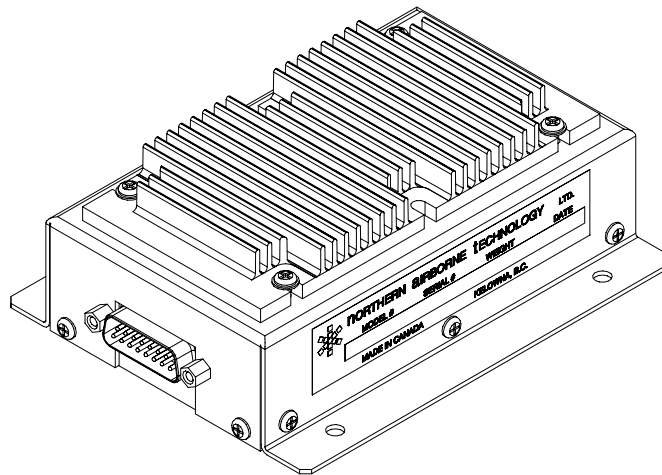

SM23

**AA23
Speaker Amplifier**



INSTALLATION AND OPERATION MANUAL

REV 4.00 November 21, 2003

**Northern Airborne Technology Ltd.
1925 Kirschner Road
Kelowna BC, Canada
V1Y 4N7**

**Telephone (250) 763-2232
Facsimile (250) 762-3374**

Copyright 2003 by Northern Airborne Technology

Periodically NAT will release manual amendments. In order to maintain the most accurate and up to date manual these amendments should be carried out immediately upon receipt and recorded on the following amendment record.

AMENDMENT RECORD				
Amendment Number	Amendment Date	Section(s) Changed	Date Entered	Entered By
809-0001	Oct 29,2004	2	Oct 29,2004	Performed at factory

Insert any Amendment Instruction sheets after this page.

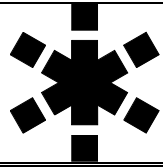

nat

**INSTALL_OPS MANUAL
AMENDMENT**

Manual: SM23 (AA23)

Amendment #: 1

Document # SM23\Install_Ops\809-0001

Amendment Date: Oct 29, 2004

The purpose of this amendment is to add the most recent drawings to the installation section of the manual.

Amendment Instructions:

1	Remove Pages	Replace With Pages
	2-3 Rev. 4.00	2-3 Rev. 4.00 Amendment #1

2	Remove Drawings (Section 2)	Replace or add Drawings (Section 2)
	-	AA23\922-0 Rev. 1.30

Note: Ensure that all drawings are inserted in the order shown on the latest drawing lists.

- 3 Update the Amendment Record sheet at the front of the manual.
- 4 Insert this page into the manual after the Amendment Record sheet (page ii).

Manual Amendment ends after the following amended pages

Table of Contents

Section	Title	Page
1.0	Description	
1.1	Introduction	1-1
1.2	Purpose of Equipment	1-1
1.3	Features	1-1
1.4	Specifications	1-2
1.4.1	Electrical Specifications	1-2
1.4.2	Physical Specifications	1-3
1.4.3	Environmental Specifications	1-3
1.5	Accessories Required but not supplied	1-3
1.6	Unit Nomenclature	1-4
2.0	Installation	
2.1	Introduction	2-1
2.2	Unpacking and Inspection	2-1
2.3	Installation Procedures	2-1
2.3.1	Warnings	2-1
2.3.2	Cautions	2-1
2.3.3	Notes	2-2
2.3.4	Cable and Wiring	2-2
2.3.5	External Components	2-2
2.3.6	Post-Installation Checks	2-2
2.4	Continued Airworthiness	2-3
2.5	Installation Drawings	2-3
3.0	Operation	
3.1	Introduction	3-1
3.2	General	3-1
3.3	Performance	3-1

Section 1.0 Description

1.1 Introduction

This manual contains information on the AA23 Speaker Amplifier.

Information in this section consists of purpose of equipment, features and specifications.

1.2 Purpose of Equipment

The AA23 is a versatile speaker amplifier that can be used to convert balanced 600 Ω line, 150/600 Ω headset, or carbon-equivalent microphone levels to speaker outputs. The interface to the AA23 is fully floating (transformer coupled), permitting complex and long distance interconnects and providing outstanding rejection of ground loop signals. The speaker output is ground referenced.

The AA23 can be used for distributed music systems, paging, transfer of headset based systems to speaker based outputs, or as a very high powered headset booster driver. The output of the AA23 can be selected ON or OFF by a simple logic line (GND = muted) to simplify external wiring in most applications.

Extensive key logic and muting capability is also incorporated into the AA23, which addresses close cockpit installations, and provides some extra flexibility in difficult installations. Either fully muted or partially muted installations can be accomplished through interconnect pin selection.

The AA23 will drive any speaker load from 3.2 to 16 Ω , but provides optimum energy transfer into either 4 or 8 Ω loads. If operated continuously with a high average power level, the unit must have air exchange for the heat sink assembly to function properly.

1.3 Features

The AA23 incorporates a power (and fuse) monitor LED that allows in-place visual indication of unit activity. The LED will turn off if either the external breaker or internal fuse is tripped.

The AA23 incorporates an internal noise filter to eliminate DC coupled interference into the system.

To provide a choice of bandpass operation (voice or music), the AA23 has an internal jumper selection. With the jumper installed, the bandpass is slightly reduced to provide better voice performance and improved feedback reduction. With the jumper removed, wide band music operation can be achieved. The units are shipped with the **jumper installed**.

An internal trimpot is provided to permit level adjustment of the over-all system. As shipped, range remains in both directions, up and down.

A set of uncommitted relay contacts (2 A rating) is provided that is closed when the unit receives a mute command (key ground input). This can be used for external switching.

Fully muted (no output) and partially muted outputs are available to provide a choice of enabled or disabled speaker sidetone. The muting circuit inserts a 44 Ω resistor in series with the load, to reduce the output level.

Two external, unrelated key inputs can mute the AA23, and both provide a flow-through key output to other systems. This permits two users in a close cockpit installation to mute each other's speakers to prevent feedback, and provides outputs to the balance of the audio system for TX keying.

The headset input places a greater than 1.8 k Ω load on the existing headset driver system, which represents a negligible load. It is a fully floating input, and will not introduce any ground loop interference unless grounded via the user interconnect. This line is meant for signals of typically +17 dBm to +20 dBm (50 mW/600 Ω).

The 600 Ω line input can be used with lower level sources to provide a speaker buffer as needed. Input sources can be music, radio feeds (via a pad) or other sources. Note that this connection is the direct input to the AA23 transformer, and is isolated from the headset input only by a simple resistive pad. Signals injected here may appear back at the headset input, and cause problems if isolation was intended.

The mic input accepts a 'carbon-equivalent' unit, and has internal excitation from the AA23. The input is floating, and **must have a ground at the input low connection to excite the microphone**. This is normally provided by any NAT audio system if used to provide the mic input (PA position).

1.4 Specifications

1.4.1 Electrical Specifications

Input Power	+22 to 32 Vdc.
Supply Current	1.0 A max. (at full output into 3.2 Ω). 0.3 to 0.5 A (typical)
Input Levels	
600 Ω input	0.45 Vrms (-5 dBm) at 1 kHz.
H/S Input	7.70 Vrms (+20 dBm) at 1 kHz.
Mic Input	0.25 Vrms at 1 kHz.

Output Levels

3.2 Ω Load	9.0 Wrms @ 1 kHz with <0.6% distortion.
4.0 Ω Load	7.5 Wrms @ 1 kHz with <0.6% distortion.
8.0 Ω Load	4.5 Wrms @ 1 kHz with <0.5% distortion.
16 Ω Load	2.5 Wrms @ 1 kHz with <0.3% distortion.
Input Logic	Key inputs are active LOW (GND = MUTED).
Output Logic	Key outputs are diode isolated and track their respective inputs less a 0.7 V diode drop.

1.4.2 Physical Specifications

Height	1.73 in (43.8 mm) including top heatsink.
Depth	5.20 in (132.1 mm) excluding connector. Allow 5 cm clearance for cable and connector.
Width	3.95 in (100.3 mm) including mounting flange.
Weight	0.78 lb (355 g) less mating connector.
Mounting	4 x 10-32 mounting bolt/screw.
Mounting Hole Centers	3.60 in (91.4 mm) by 3.45 in (87.6 mm).

1.4.3 Environmental Specifications

Temperature	-20° C to + 65° C.
Altitude	15,000 ft. max.
Humidity	95 % Non-Condensing.
Shock	12 g. (any axis)

1.5 Accessories Required but not Supplied

Installation kit p/n AA23-IKC (crimp) or AA23-IKS (solder) is required to complete the installation. They consist of the following:

AA23-IKC 15 Pin D-min Female Crimp Kit (NAT Part # D15SL-IKC)

Quantity	Description	NAT Part #
1	D-min 15 Socket Housing	20-21-015
15	MS Crimp Socket	20-26-901
1*	Jack Screw Set	20-27-002
1*	Lock Clip Set	20-27-004
1	15 Pin Connector Hood	20-29-015

* Use as required.

AA23-IKS 15 Pin D-min Female Solder Kit (NAT Part # D15SL-IKS)

Quantity	Description	NAT Part #
1	D-min 15 Socket Solder Cup	20-20-015
1*	Jack Screw Set	20-27-002
1*	Lock Clip Set	20-27-004
1	15 Pin Connector Hood	20-29-015

* Use as required.

1.6 Unit Nomenclature

Model	Description / Distinction
AA23-001	Accepts Mic., 600 Ω Line and H/S inputs, with floating interface. Muted or partially muted outputs. Dual PTT key logic inputs and outputs. Selectable frequency response, Voice or Music. Adjustable gain.
AA23-002	Accepts Mic. and two H/S inputs, with floating interface. Muted or partially muted outputs. Dual PTT key logic inputs and outputs. Selectable frequency response, Voice or Music. Adjustable gain.

End of section 1.0

Section 2.0 Installation

2.1 Introduction

Information in this section consists of: unpacking and inspection procedures, installation procedures, post-installation checks, and installation drawings.

2.2 Unpacking and Inspection

Unpack the equipment carefully, and locate the warranty card. Inspect the unit visually for damage due to shipping and report all such claims immediately to the carrier involved. Note that each unit should have the following;

- AA23 Speaker Amplifier
- Warranty Card
- Release certification

Verify that all items are present before proceeding, and report any shortage immediately to your supplier.

Complete the warranty card information, and send it to NAT when the installation is complete. If you fail to complete the warranty card, the warranty will be activated on date of shipment from NAT.

2.3 Installation Procedures

2.3.1 Warnings

Do not bundle any lines from this unit with transmitter coax lines, or AM audio rectification may result. Do not bundle any input or output audio, or DC power lines from this unit with 400 Hz synchro wiring or AC power lines. Do not position this unit or wiring from this unit next to any device with a strong alternating magnetic field such as an inverter, or significant audio interference will result.

2.3.2 Cautions

In all installations, use shielded cable exactly as shown and ground as indicated. Significant problems may result from not following these guidelines, especially with regard to ground loop noise.

2.3.3 Notes

The 600 Ω line input is a low level audio line, and connects to a sensitive point in the AA23. This line must be shielded, and routed to avoid pick-up of stray fields in the aircraft. The same holds true for the Headset and Mic inputs. Failure to do this will result in noisy operation, and will easily pick up interference if poorly installed and routed.

2.3.4 Cable and Wiring

All unshielded wire should be MIL-W-22759 or equivalent. For shielded wire applications, use Tefzel MIL-C-27500 shielded wire with solder sleeves (for shield terminations) to make the most compact and easily terminated interconnect. Follow the wiring diagrams in Section 2.5 as required.

Allow 3 inches from the end of the wire to the shield termination to allow the hood to be easily installed. Note that the hood is a “clamshell” hood, and is installed **after** the wiring is complete.

All wiring should be 22 AWG, except power, output and ground connections, which must be at least 20 AWG. Ensure that the ground connection is clean and well secured. A 1 A fuse or breaker is recommended (28 VDC Source).

2.3.5 External Components

When used as a multiple headset driver, some type of external series resistor is useful to prevent shorted headsets or cables from shutting down the system.

2.3.6 Post-Installation Checks

With the AA23 disconnected from its mating connector, carry out the following checks:

- a) Check pin <1> for +28 Vdc relative to ground, and pin <9> for continuity to ground (below 0.5 Ω).
- b) Check for the correct load resistance on pin <7> or < 8>, to a return on pin <15>. Do **not** power up unit if load resistance **shows a short**.

Do not attach the AA23 until these conditions are met, or damage may result to the unit which is **not covered under warranty**.

2.4 Continued Airworthiness

Maintenance of the AA23 is 'on condition' only. Periodic maintenance of this product is not required.

2.5 Installation Drawings

DRAWING	REV.	DESCRIPTION	TYPE	SERIAL #
AA23\922-0	1.20	Speaker Amplifier	Mechanical Installation	Up to 1267
AA23\922-0	1.30	Speaker Amplifier	Mechanical Installation	1268 and up
AA23-001				
AA23\001\403-0	1.11	Speaker Amplifier	Interconnect	All
AA23\001\403-1	1.11	Speaker Amplifier	Interconnect	All
AA23\001\403-2	1.11	Speaker Amplifier	Interconnect	All
AA23\001\405-0	1.02	Speaker Amplifier	Connector Map	All
AA23-002				
AA23\002\403-0	1.11	Speaker Amplifier	Interconnect	All
AA23\002\403-1	1.11	Speaker Amplifier	Interconnect	All
AA23\002\403-2	1.11	Speaker Amplifier	Interconnect	All
AA23\002\405-0	1.00	Speaker Amplifier	Connector Map	All

Section 2.0 ends after these Drawings

REVISIONS

REV	DESCRIPTION	DATE	BY
1.10	ECR #1264 - HEATSINK REDESIGN.	NOV 4/98	TGM
1.20	ECR #162 - COVER AND CHASSIS REDESIGNED, LABEL ADDED, FORMAT CHANGES.	NOV 16/00	TAT

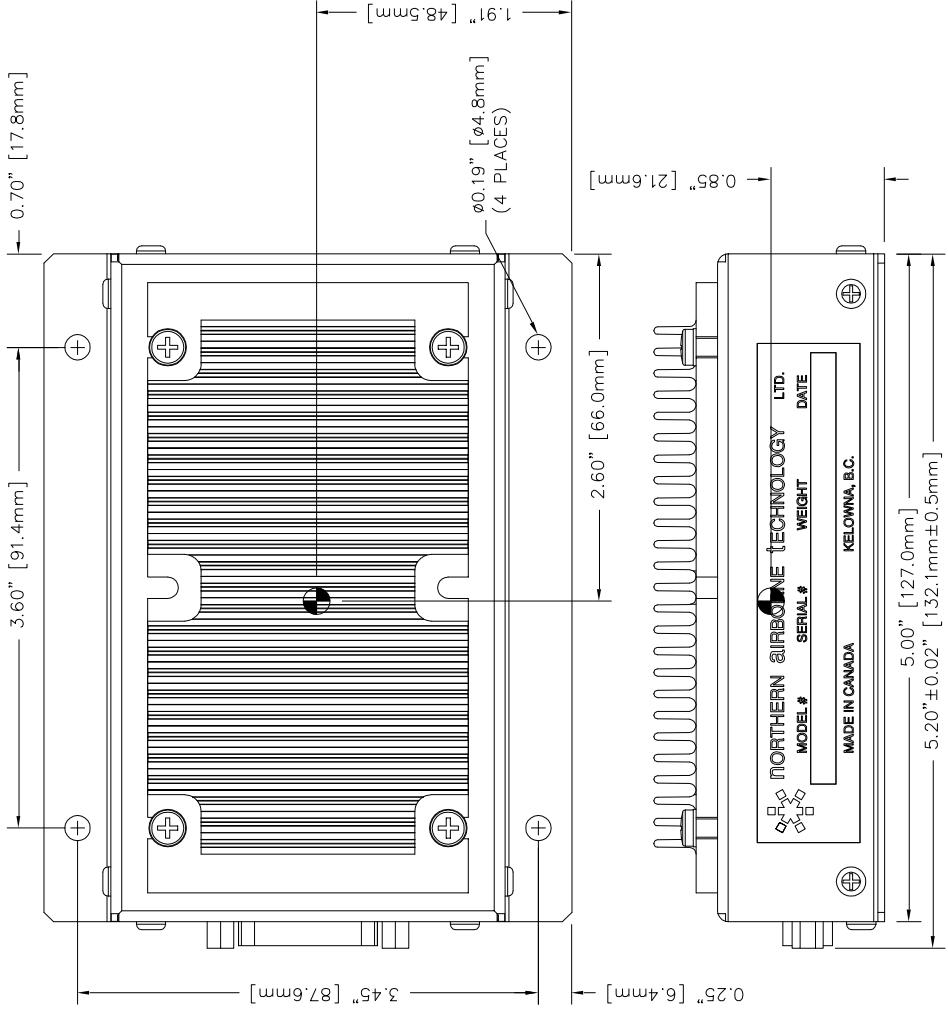

WEIGHT: 0.78 lbs (355 g)
 ● CENTER OF GRAVITY ±0.05" [1.3mm]

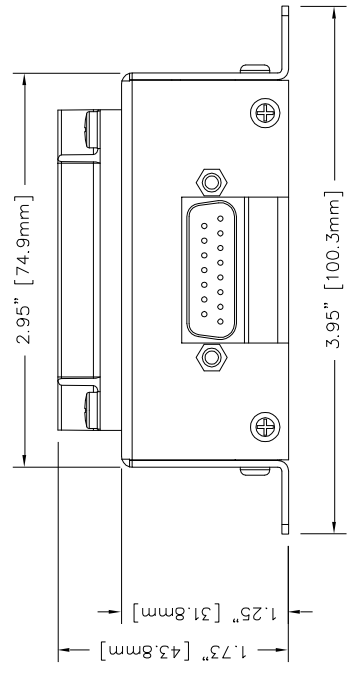

PROPRIETARY AND CONFIDENTIAL TO NAT LTD.

TOLERANCES UNLESS STATED OTHERWISE	DIMENSIONS IN INCHES	DESIGNED	KV	NORTHERN AIRBORNE TECHNOLOGY LTD.		
0.X=+/-0.030	THIRD ANGLE PROJECTION	DRAWN	TGM	SIZE	CAGE CODE	PART NO.
0.XX=+/-0.010		DATE	JUN 15/95	A	3AB01	AA23
0.XXX=+/-0.005		CHECKED		NAT 114	NAT 223	
0.XXXX=+/-0.002	MATERIAL	APPROVED				
ANGLE=+/- 0.5 DEG.	FINISH	FILE	922-0120.DWG	DWG. TYPE	MECH. INSTALLATION	DWG. NO.
						AA23\922-0

TITLE
 SPEAKER AMPLIFIER

REV. SHEET
 1.20 1/1

REVISIONS

REV	DESCRIPTION	DATE	BY
1.10	ECR #1264 - HEATSINK REDESIGN.	NOV 4/98	TGM
1.20	ECR #162 - COVER AND CHASSIS REDESIGNED, LABEL ADDED, FORMAT CHANGES.	NOV 16/00	TAT
1.30	ECR #1730 - HEATSINK CHANGED BACK TO ORIGINAL, FORMAT CHANGES.	OCT 9/01	TAT

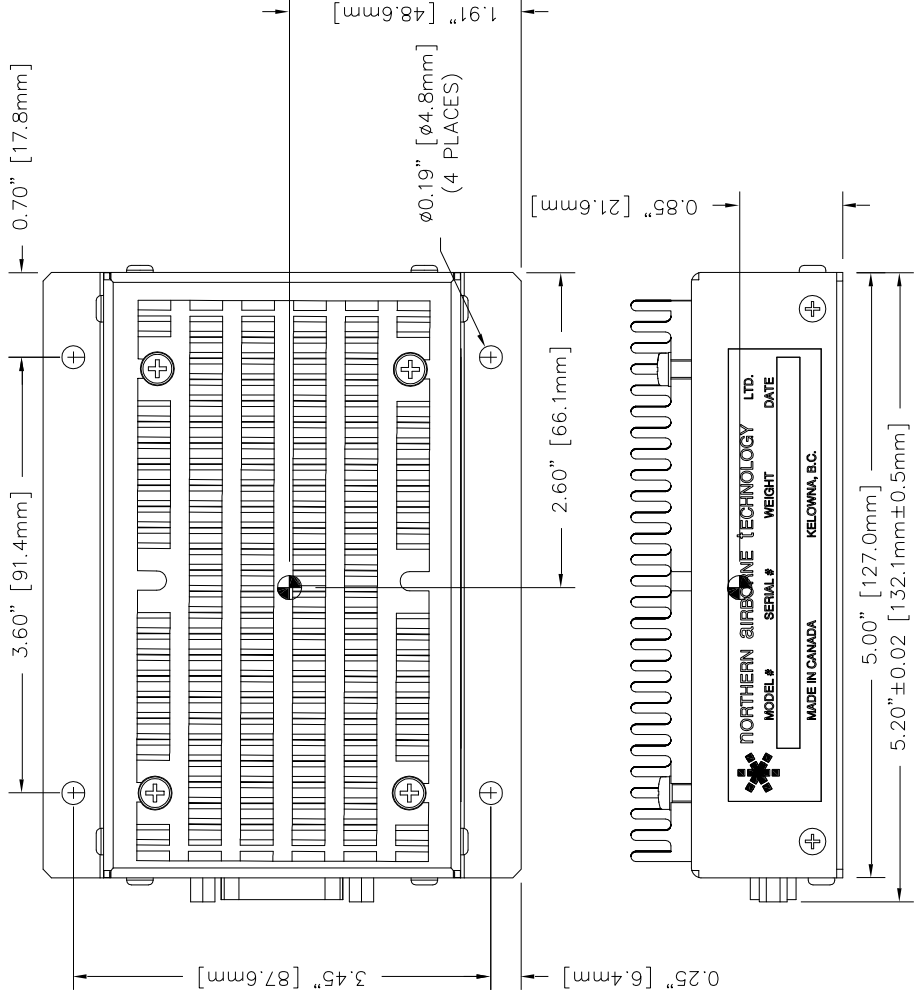

WEIGHT: 0.78 ±0.04 lbs (0.36 ±0.02Kg)
 ● CENTER OF GRAVITY ±0.05" [1.3mm]

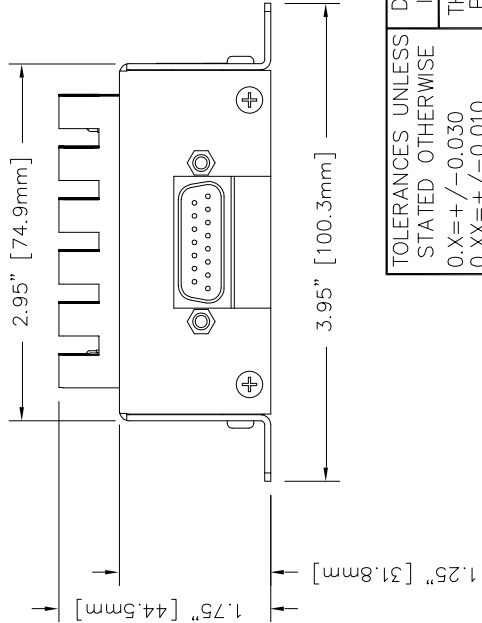

CONFIDENTIAL AND PROPRIETARY TO NAT LTD.

NORTHERN AIRBORNE TECHNOLOGY LTD.		TITLE SPEAKER AMPLIFIER	
DESIGNED	KV	CAGE CODE	PART NO.
DRAWN	TGM	3AB01	AA23
DATE	JUN 15/95	SIZE	A
CHECKED	NAT 118 NAT 113	DWG. TYPE	MECH. INSTALLATION
APPROVED	NAT 117	DWG. NO.	AA23\922-0
TOLERANCES UNLESS STATED OTHERWISE	FINISH		
0.X=+/-0.030	MATERIAL		
0.XX=+/-0.010	DIMS IN INCHES		
0.XXX=+/-0.005	THIRD ANGLE PROJECTION		
0.XXXX=+/-0.002			
ANGLE=+/-0.5 DEG.	FILE 922-0130.DWG		
SHEET 1/1		REV. 1.30	

REVISIONS			
REV	DESCRIPTION	DATE	BY
A	DRAWING CORRECTIONS	FEB 4/93	RL
1.02	FORMAT CHANGES, DRAWING CORRECTIONS	JUN 16/95	KV
1.10	ECR #639 CORRECTED SPEAKER OUTPUT LABELS	JAN 8/97	MWS
1.11	ECR #897 - NOTES 1 AND 5 CHANGED, FORMAT CHANGES.	DEC 4/00	TAT

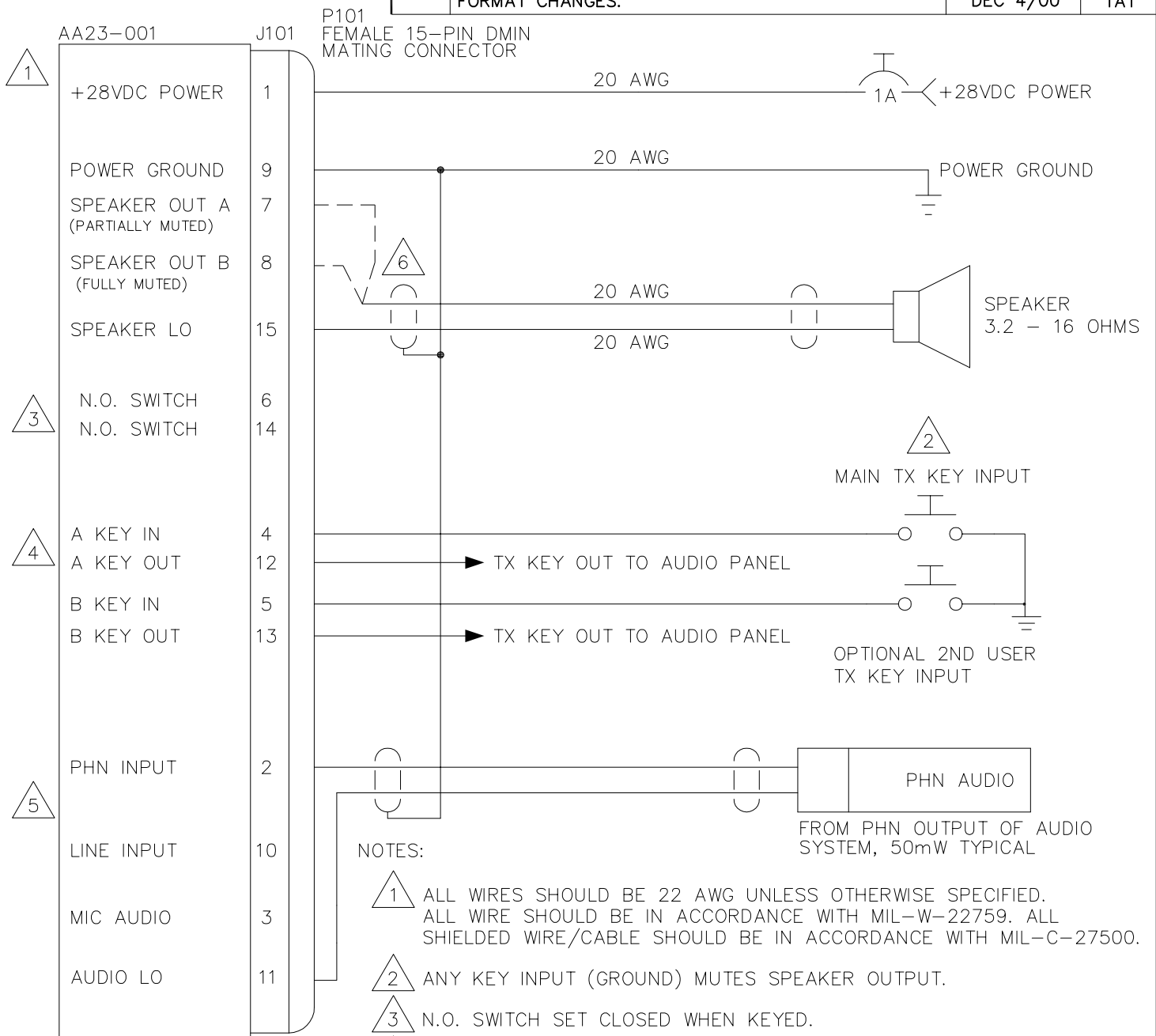

- NOTES:
- 1 ALL WIRES SHOULD BE 22 AWG UNLESS OTHERWISE SPECIFIED. ALL WIRE SHOULD BE IN ACCORDANCE WITH MIL-W-22759. ALL SHIELDED WIRE/CABLE SHOULD BE IN ACCORDANCE WITH MIL-C-27500.
 - 2 ANY KEY INPUT (GROUND) MUTES SPEAKER OUTPUT.
 - 3 N.O. SWITCH SET CLOSED WHEN KEYED.
 - 4 A DIODE IS PRESENT BETWEEN KEY IN AND KEY OUT.
 - 5 INPUTS ARE FLOATING (TRANSFORMER COUPLED), "AUDIO LO" NEEDS REFERENCING TO A 'LO' OR 'GROUND'.
 - 6 CONNECT TO ONE OUTPUT ONLY.

PROPRIETARY AND CONFIDENTIAL TO NAT LTD.

DESIGNED	KV	NAT NORTHERN AIRBORNE TECHNOLOGY LTD.				
DRAWN	KV					
DATE	NOV 26/92	TITLE				
CHECKED		SPEAKER AMPLIFIER, HEADSET TO SPEAKER INTERCONNECT				
APPROVED		SIZE	CAGE CODE	PART NO.	REV.	SHEET
FILE	403-0111.DWG	A	3AB01	AA23-001	1.11	1/1
DWG. TYPE		INTERCONNECT		DWG. NO. AA23\001\403-0		

REVISIONS			
REV	DESCRIPTION	DATE	BY
A	DRAWING CORRECTIONS	FEB 4/93	RL
1.02	FORMAT CHANGES, DRAWING CORRECTIONS	JUN 16/95	KV
1.10	ECR #639 CORRECTED SPEAKER OUTPUT LABELS	JAN 3/97	MWS
1.11	ECR #897 - NOTES 1, 2 & 5 CHANGED, NOTE 6 ADDED, WORDING ON PINS 4 & 12 CHANGED, FORMAT CHANGES.	DEC 4/00	TAT

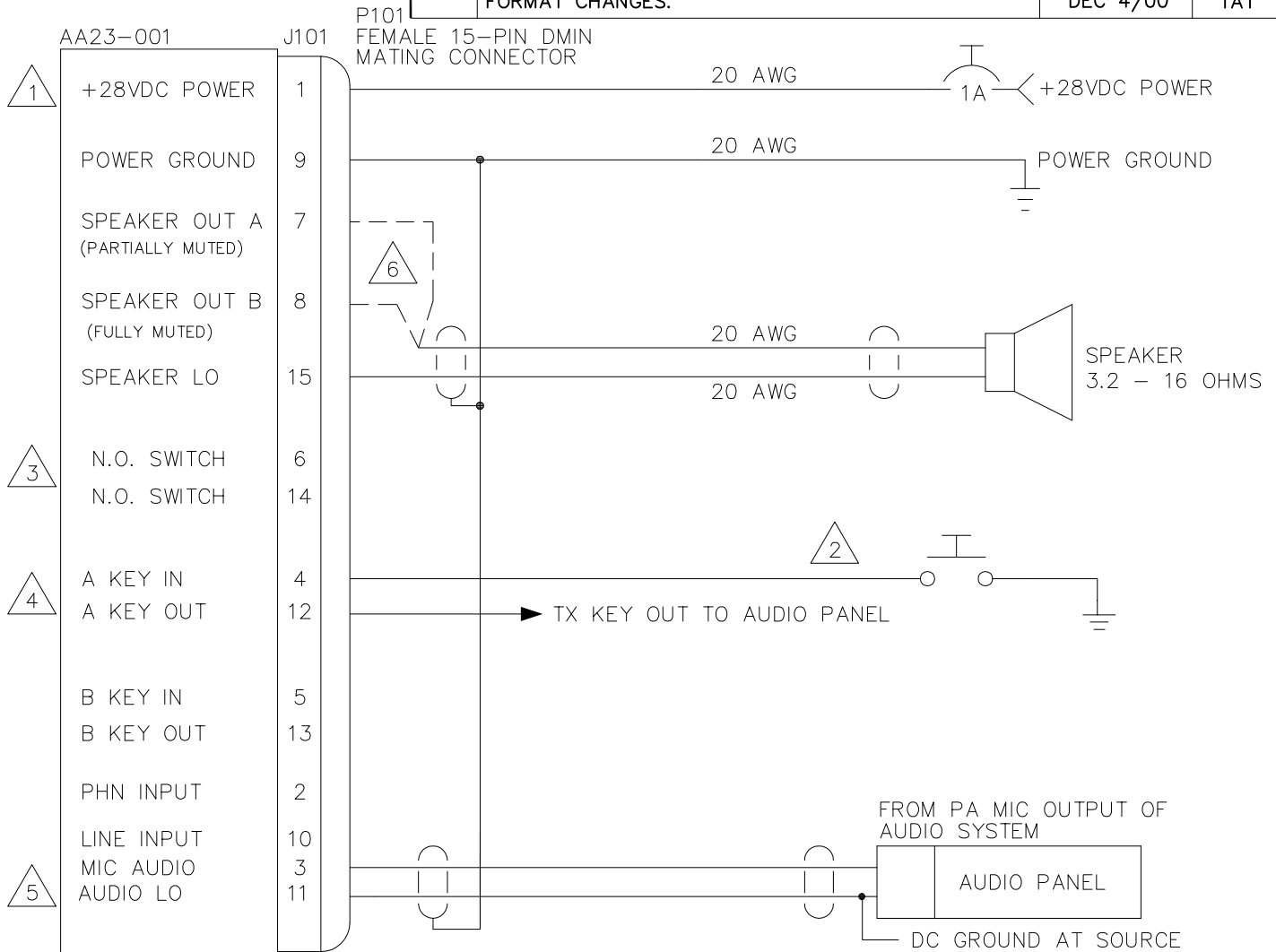

NOTES:

- 1 ALL WIRES SHOULD BE 22 AWG UNLESS OTHERWISE SPECIFIED. ALL WIRE SHOULD BE IN ACCORDANCE WITH MIL-W-22759. ALL SHIELDED WIRE/CABLE SHOULD BE IN ACCORDANCE WITH MIL-C-27500.
- 2 ANY KEY INPUT (GROUND) MUTES SPEAKER OUTPUT.
- 3 N.O. SWITCH SET CLOSED WHEN KEYED.
- 4 A DIODE IS PRESENT BETWEEN KEY IN AND KEY OUT.
- 5 INPUTS ARE FLOATING (TRANSFORMER COUPLED), "AUDIO LO" NEEDS REFERENCING TO A 'LO' OR 'GROUND'.
- 6 CONNECT TO ONE OUTPUT ONLY.

PROPRIETARY AND CONFIDENTIAL TO NAT LTD.

DESIGNED	KV	NAT NORTHERN AIRBORNE TECHNOLOGY LTD.				
DRAWN	KV					
DATE	NOV 29/92	TITLE SPEAKER AMPLIFIER, PA INTERCONNECT				
CHECKED						
APPROVED		SIZE	CAGE CODE	PART NO.	REV.	SHEET
FILE	403-1111.DWG	A	3AB01	AA23-001	1.11	1/1
DWG. TYPE		INTERCONNECT		DWG. NO. AA23\001\403-1		

REVISIONS			
REV	DESCRIPTION	DATE	BY
A	DRAWING CORRECTIONS	FEB 4/93	RL
1.02	FORMAT CHANGES, DRAWING CORRECTIONS	JUN 16/95	KV
1.10	ECR #639 CORRECTED SPEAKER OUTPUT LABELS	JAN 3/97	MWS
1.11	ECR #897 - NOTES 1, 2 & 5 CHANGED, NOTE 6 ADDED, WORDING ON PINS 4 & 12 CHANGED, FORMAT CHANGES.	DEC 4/00	TAT

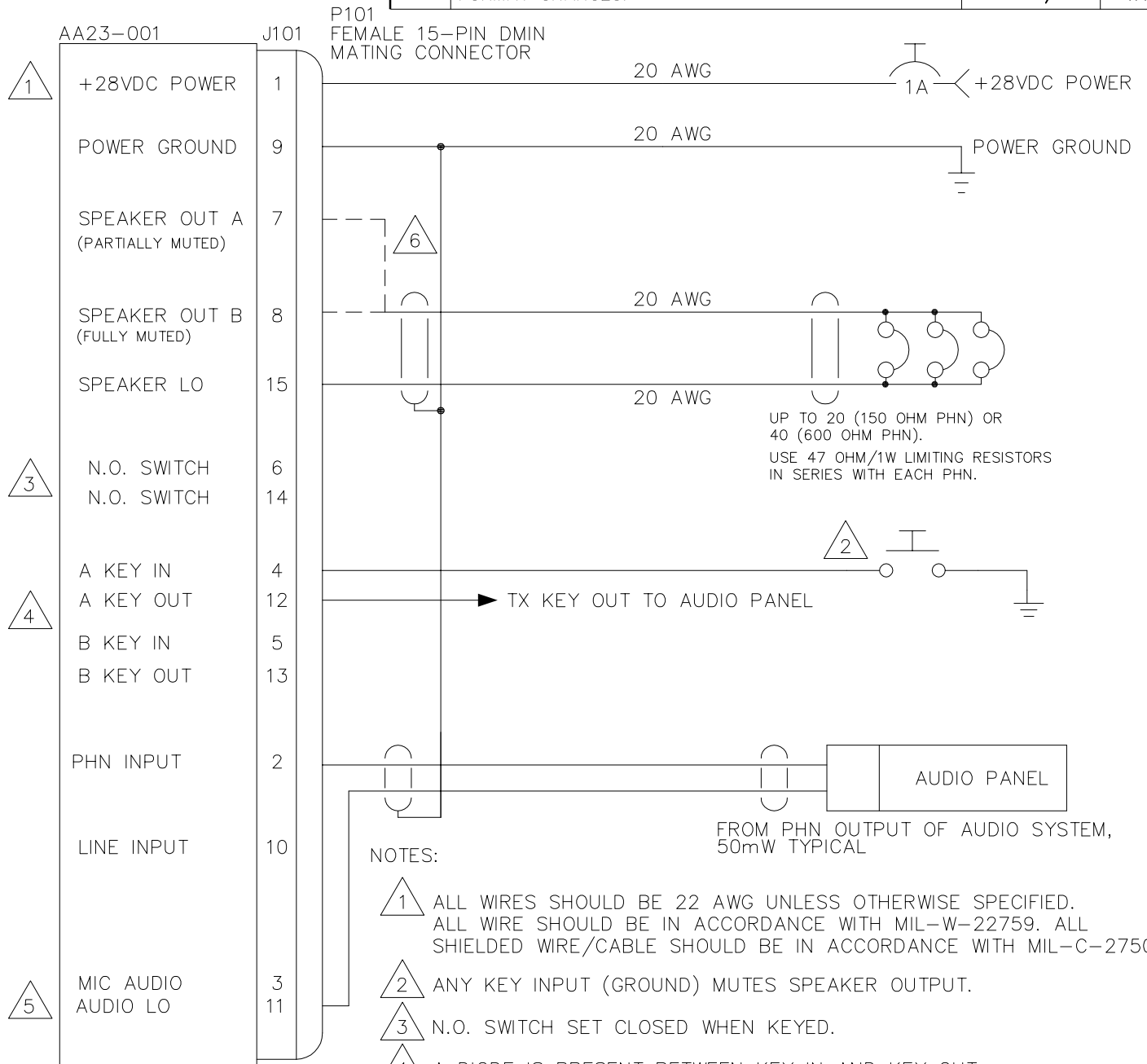

NOTES:

- 1 ALL WIRES SHOULD BE 22 AWG UNLESS OTHERWISE SPECIFIED. ALL WIRE SHOULD BE IN ACCORDANCE WITH MIL-W-22759. ALL SHIELDED WIRE/CABLE SHOULD BE IN ACCORDANCE WITH MIL-C-27500.
- 2 ANY KEY INPUT (GROUND) MUTES SPEAKER OUTPUT.
- 3 N.O. SWITCH SET CLOSED WHEN KEYED.
- 4 A DIODE IS PRESENT BETWEEN KEY IN AND KEY OUT.
- 5 INPUTS ARE FLOATING (TRANSFORMER COUPLED), "AUDIO LO" NEEDS REFERENCING TO A 'LO' OR 'GROUND'.
- 6 CONNECT TO ONE OUTPUT ONLY.

PROPRIETARY AND CONFIDENTIAL TO NAT LTD.

DESIGNED	KV	NAT NORTHERN AIRBORNE TECHNOLOGY LTD.				
DRAWN	KV					
DATE	NOV 26/92	TITLE SPEAKER AMPLIFIER, HEADSET BOOSTER INTERCONNECT				
CHECKED						
APPROVED		SIZE	CAGE CODE	PART NO.	REV.	SHEET
FILE	403-2111.DWG	A	3AB01	AA23-001	1.11	1/1
DWG. TYPE		INTERCONNECT		DWG. NO. AA23\001\403-2		

REVISIONS			
REV	DESCRIPTION	DATE	BY
1.01	FORMAT CHANGES.	JUN 15/95	KV
1.02	ECR #897 - FORMAT CHANGES.	NOV 9/00	TAT

P101
 15 PIN FEMALE DMIN
 MATING CONNECTOR

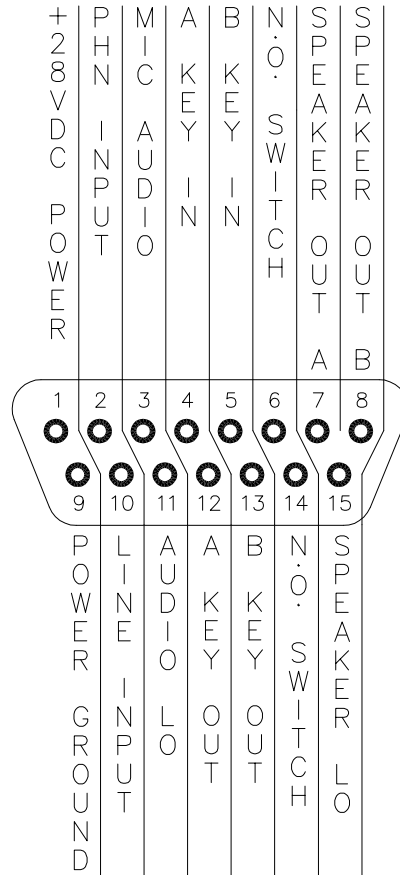

VIEW IS FROM REAR OF AIRFRAME CONNECTOR

PROPRIETARY AND CONFIDENTIAL TO NAT LTD.

DESIGNED	WS2	NAT NORTHERN AIRBORNE TECHNOLOGY LTD.				
DRAWN	KV					
DATE	SEP 22/92	TITLE	SPEAKER AMPLIFIER			
CHECKED	<div style="display: inline-block; border: 1px solid black; padding: 2px;">NAT 200</div> <div style="display: inline-block; border: 1px solid black; padding: 2px; margin-left: 10px;">NAT 223</div>					
APPROVED	<div style="display: inline-block; border: 1px solid black; border-radius: 50%; padding: 5px;">NAT 107</div>	SIZE	CAGE CODE	PART NO.	REV.	SHEET
		A	3AB01	AA23-001	1.02	1/1
FILE	405-0102.DWG	DWG. TYPE	CONNECTOR MAP	DWG. NO.	AA23\001\405-0	

REVISIONS			
REV	DESCRIPTION	DATE	BY
1.01	REMOVED LINE AUDIO RESISTORS, ADDED NOTES.	JUN 16/95	KV
1.10	ECR /3639 CORRECTED SPEAKER OUTPUT LABELS	JAN 8/97	MWS
1.11	ECR /3897 - NOTES 1, 2 AND 5 CHANGED, FORMAT CHANGES.	DEC 4/00	TAT

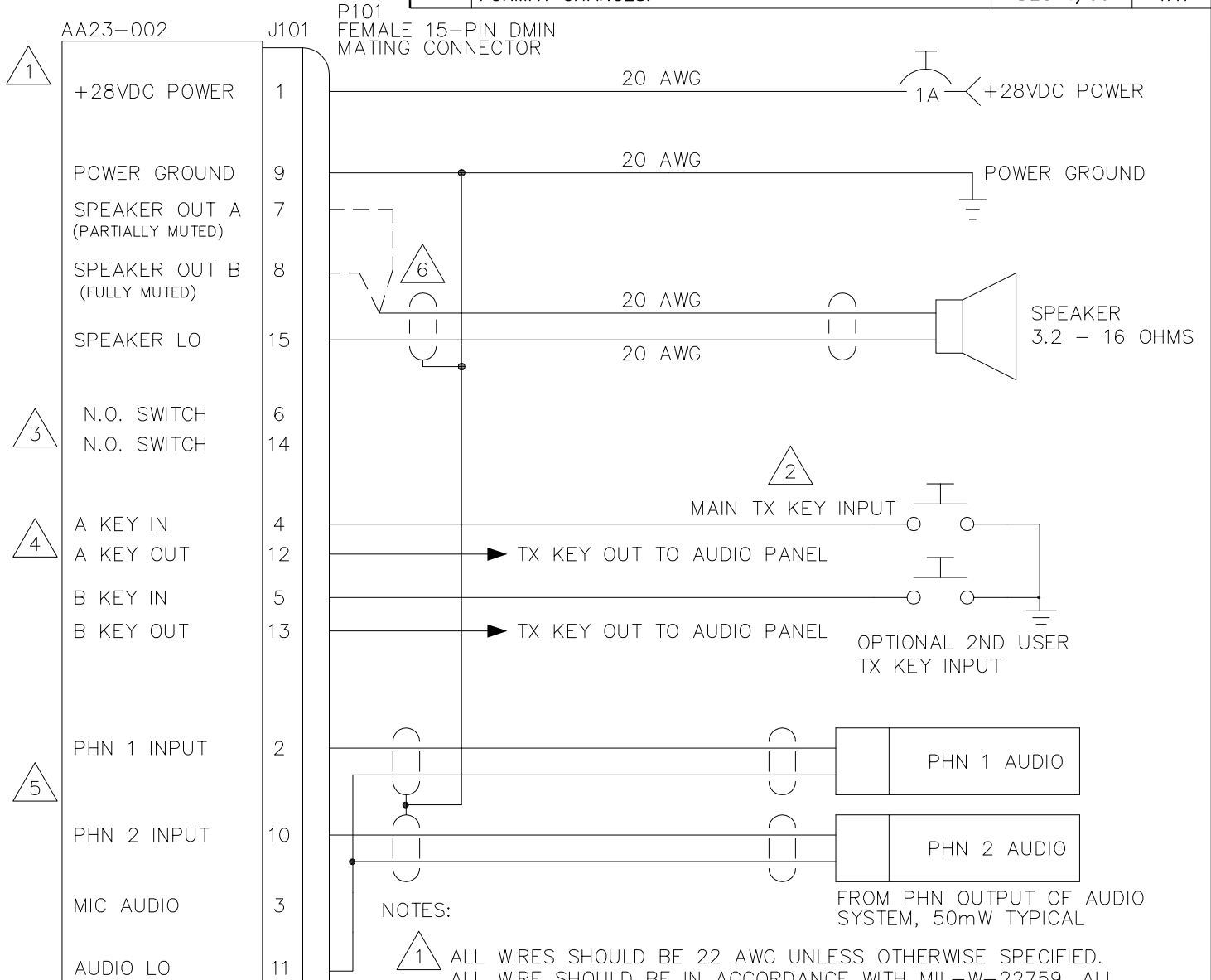

- NOTES:
- 1 ALL WIRES SHOULD BE 22 AWG UNLESS OTHERWISE SPECIFIED. ALL WIRE SHOULD BE IN ACCORDANCE WITH MIL-W-22759. ALL SHIELDED WIRE/CABLE SHOULD BE IN ACCORDANCE WITH MIL-C-27500.
 - 2 ANY KEY INPUT (GROUND) MUTES SPEAKER OUTPUT.
 - 3 N.O. SWITCH SET CLOSED WHEN KEYED.
 - 4 A DIODE IS PRESENT BETWEEN KEY IN AND KEY OUT.
 - 5 INPUTS ARE FLOATING (TRANSFORMER COUPLED), "AUDIO LO" NEEDS REFERENCING TO A 'LO' OR 'GROUND'.
 - 6 CONNECT TO ONE OUTPUT ONLY.

PROPRIETARY AND CONFIDENTIAL TO NAT LTD.

DESIGNED	KV	NAT NORTHERN AIRBORNE TECHNOLOGY LTD.	TITLE SPEAKER AMPLIFIER, HEADSET TO SPEAKER INTERCONNECT			
DRAWN	KV					
DATE	JAN 30/95					
CHECKED		SIZE	CAGE CODE	PART NO.	REV.	SHEET
APPROVED		A	3AB01	AA23-002	1.11	1/1
FILE	403-0111.DWG	DWG. TYPE	INTERCONNECT	DWG. NO.	AA23\002\403-0	

REVISIONS			
REV	DESCRIPTION	DATE	BY
1.10	ECR #639 CORRECTED SPEAKER OUTPUT LABELS	JAN 3/97	MWS
1.11	ECR #897 - NOTES 1, 2 & 5 CHANGED, NOTE 6 ADDED, WORDING ON PINS 4 & 12 CHANGED, FORMAT CHANGES.	DEC 4/00	TAT

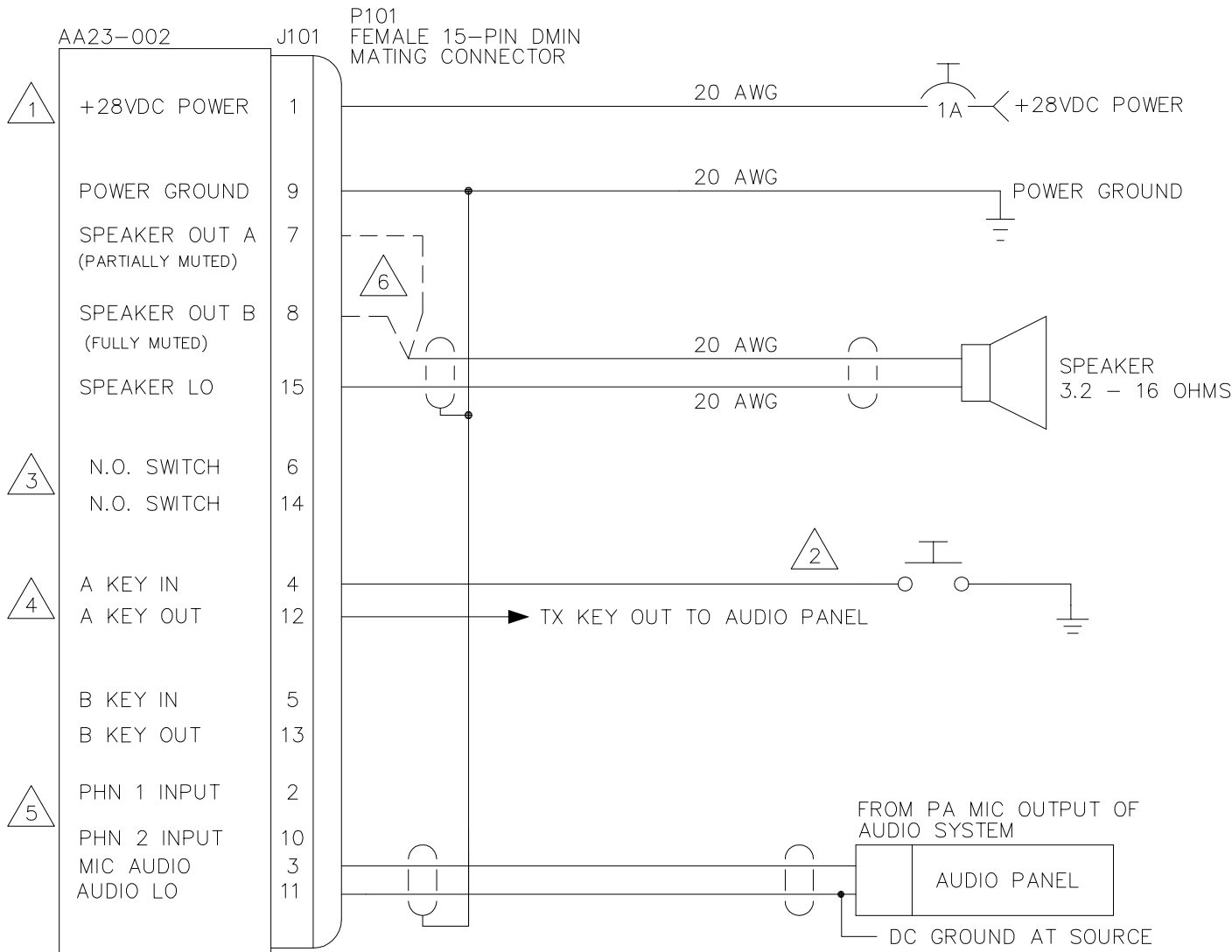

- NOTES:
- 1 ALL WIRES SHOULD BE 22 AWG UNLESS OTHERWISE SPECIFIED. ALL WIRE SHOULD BE IN ACCORDANCE WITH MIL-W-22759. ALL SHIELDED WIRE/CABLE SHOULD BE IN ACCORDANCE WITH MIL-C-27500.
 - 2 ANY KEY INPUT (GROUND) MUTES SPEAKER OUTPUT.
 - 3 N.O. SWITCH SET CLOSED WHEN KEYED.
 - 4 A DIODE IS PRESENT BETWEEN KEY IN AND KEY OUT.
 - 5 INPUTS ARE FLOATING (TRANSFORMER COUPLED), "AUDIO LO" NEEDS REFERENCING TO A 'LO' OR 'GROUND'.
 - 6 CONNECT TO ONE OUTPUT ONLY.

PROPRIETARY AND CONFIDENTIAL TO NAT LTD.

DESIGNED	KV	 NAT NORTHERN AIRBORNE TECHNOLOGY LTD.	TITLE SPEAKER AMPLIFIER, PA INTERCONNECT			
DRAWN	KV					
DATE	JUN 16/95	REV. 1.11				SHEET 1/1
CHECKED	NAT 114 NAT 223					
APPROVED	NAT 107	SIZE A	CAGE CODE 3AB01	PART NO. AA23-002	REV. 1.11	SHEET 1/1
FILE	403-1111.DWG	DWG. TYPE	INTERCONNECT	DWG. NO.	AA23\002\403-1	



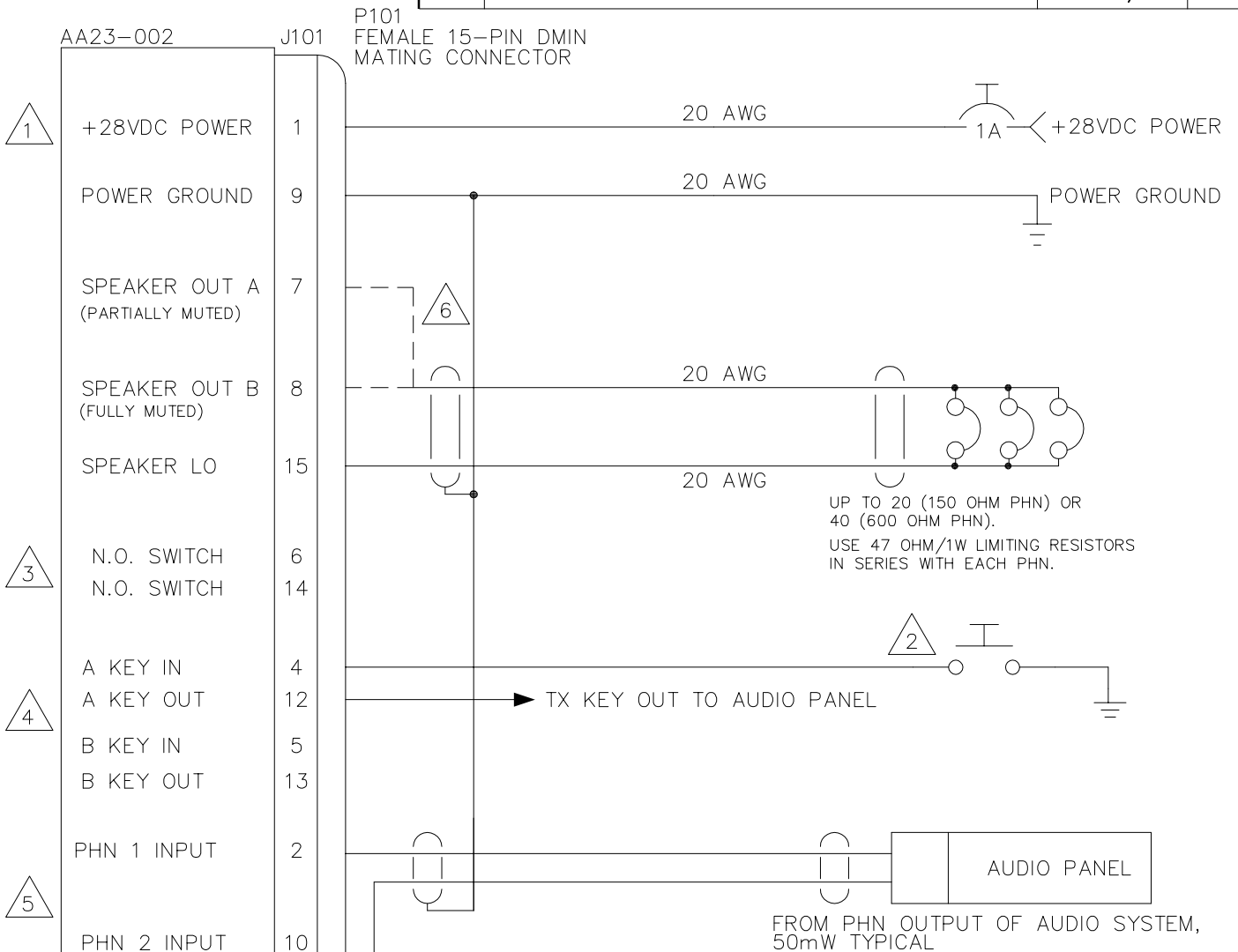

REVISIONS			
REV	DESCRIPTION	DATE	BY
1.10	ECR #639 CORRECTED SPEAKER OUTPUT LABELS	JAN 3/97	MWS
1.11	ECR #897 - NOTES 1, 2 & 5 CHANGED, NOTE 6 ADDED, WORDING ON PINS 4 & 12 CHANGED, FORMAT CHANGES.	DEC 4/00	TAT



NOTES:

- ① ALL WIRES SHOULD BE 22 AWG UNLESS OTHERWISE SPECIFIED. ALL WIRE SHOULD BE IN ACCORDANCE WITH MIL-W-22759. ALL SHIELDED WIRE/CABLE SHOULD BE IN ACCORDANCE WITH MIL-C-27500.
- ② ANY KEY INPUT (GROUND) MUTES SPEAKER OUTPUT.
- ③ N.O. SWITCH SET CLOSED WHEN KEYED.
- ④ A DIODE IS PRESENT BETWEEN KEY IN AND KEY OUT.
- ⑤ INPUTS ARE FLOATING (TRANSFORMER COUPLED), "AUDIO LO" NEEDS REFERENCING TO A 'LO' OR 'GROUND'.
- ⑥ CONNECT TO ONE OUTPUT ONLY.

PROPRIETARY AND CONFIDENTIAL TO NAT LTD.

DESIGNED	KV	 NAT NORTHERN AIRBORNE TECHNOLOGY LTD.	TITLE SPEAKER AMPLIFIER, HEADSET BOOSTER INTERCONNECT			
DRAWN	KV					
DATE	JUN 16/95	REV. SHEET 1.11 1/1				
CHECKED	 					
APPROVED		SIZE A	CAGE CODE 3AB01	PART NO. AA23-002	REV. SHEET 1.11 1/1	
FILE	403-2111.DWG	DWG. TYPE	INTERCONNECT	DWG. NO.	AA23\002\403-2	

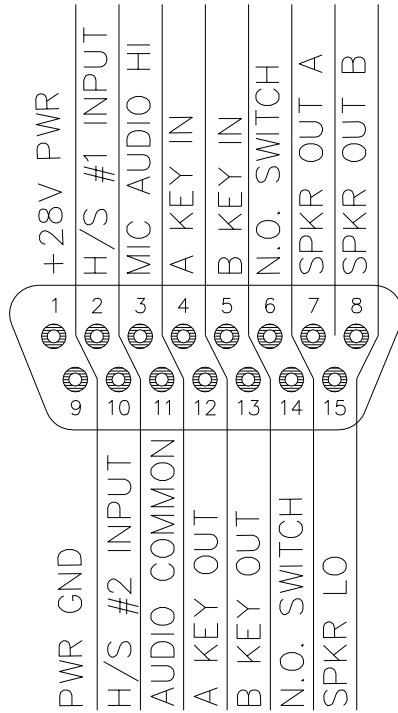

J101

Confidential and Proprietary to NAT

REVISION	DATE	*nat NORTHERN AIRBORNE TECHNOLOGY LTD.			
1.00	JUNE 14/95	DESIGNED BY	DESCRIPTION		
		K VEITCH	SPEAKER AMPLIFIER		
		DRAWN BY	PART NUMBER	DRAWING TYPE	SHEET
		K VEITCH	AA23-002	CONNECTOR MAP	1/1
		APPROVED BY	DRAWING NUMBER	FILE NUMBER	
		NAT R&D	AA23\002\405-0	AA23\002\405-0100	
		101			

Section 3.0 Operation

3.1 Introduction

Information in this section consists of the functional and operating procedures for the AA23 Speaker Amplifier.

3.2 General

The AA23 can be used for distributed music systems, paging, transfer of headset based systems to speaker based outputs, or as a very high powered headset booster driver. The AA23 will drive any speaker load from 3.2 Ω to 16 Ω , but provides optimum energy transfer into either 4 Ω or 8 Ω loads.

3.3 Performance

The **AA23 Speaker Amplifier has no normal user operational aspects.** During installation, or if the unit has been exchanged, it may be a requirement to change internal level adjustments. This should be done **ONLY BY FULLY QUALIFIED PERSONNEL.**

End of section 3.0

