

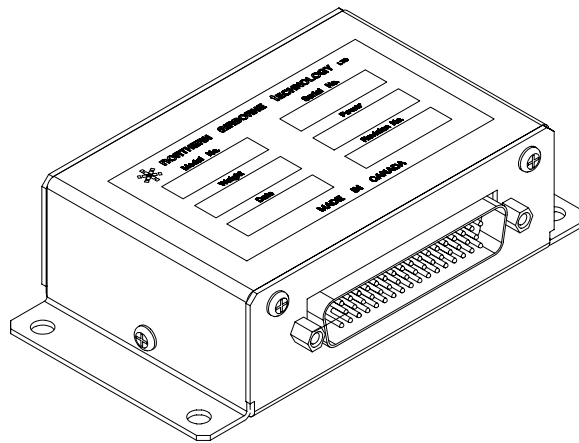

Part of
SM15

**RS08
Remote Switch**



INSTALLATION AND OPERATION MANUAL

REV 4.00 November 24, 2003

**Northern Airborne Technology Ltd.
1925 Kirschner Road
Kelowna BC, Canada
V1Y 4N7**

**Telephone (250) 763-2232
Facsimile (250) 762-3374**

Copyright 2003 by Northern Airborne Technology Ltd.

Sections 1.0 through 3.0 of this Manual are APPROVED by Transport Canada as complying with the requirements of AWM511 for Appliance Type Certificate AP-11

Periodically NAT will release manual amendments. In order to maintain the most accurate and up to date manual these amendments should be carried out immediately upon receipt and recorded on the following amendment record.

AMENDMENT RECORD				
Amendment Number	Amendment Date	Section(s) Changed	Date Entered	Entered By
1	Jan 18\05	2		Performed at factory

Insert any Amendment Instruction sheets after this page.

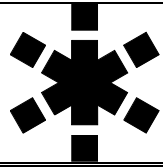

nat

**INSTALL_OPS
MANUAL AMENDMENT**

Manual: SM15 (RS08)

Amendment #: 1

Document # SM15\RS08\Install_Ops\809-0001 Amendment Date: Jan 18, 2005

The purpose of this amendment is to add the Environmental Qualification Form (521-0) to section 2.4 and to update section 2.3.2 Cable and Wiring statement paragraph 1.

Amendment Instructions:

1	Remove Pages	Replace With Pages
	2-1 to 2-3 Rev 4.00	2-1 to 2-3 Rev 4.00 Amendment #1

2	Remove Drawings/Documents (Section 2)	Replace or add Drawings/Documents (Section 2)
	-	RS08\001\521-0 Rev 1.00

Note: Ensure that all drawings are inserted in the order shown on the latest drawing lists.

3 Update the Amendment Record sheet at the front of the manual.

4 Insert this page into the manual after the Amendment Record sheet (page ii).

Manual Amendment ends after the following amended pages

Table of Contents

Section	Title	Page
1.0	Description	
1.1	Introduction	1-1
1.2	Purpose of Equipment	1-1
1.3	Features	1-1
1.4	Specifications	1-2
1.4.1	Electrical Specifications	1-2
1.4.2	Physical Specifications	1-2
1.4.3	Environmental Specifications	1-3
1.5	Unit Nomenclature	1-3
2.0	Installation	
2.1	Introduction	2-1
2.2	Unpacking and Inspection	2-1
2.3	Installation Procedures	2-1
2.3.1	Warnings	2-1
2.3.2	Cabling and Wiring	2-1
2.3.3	External Switches and Lamps	2-2
2.3.4	Post-Installation Checks	2-2
2.4	Installation Drawings	2-3
3.0	Operation	
3.1	Introduction	3-1
3.2	Mode Annunciation	3-1
3.3	NAV Selection	3-1
3.4	Annunciator Lighting	3-1
3.5	Fault Indications	3-1
3.5.1	Loss of Power	3-1
3.5.2	Failure Presentations	3-2

Section 1.0 Description

1.1 Introduction

Information in this section consists of: purpose of equipment, features, specifications, and a listing of all models available to the date of publication.

1.2 Purpose of Equipment

The RS08 is a bulkhead mounted remote switching unit. It is specifically designed to handle the switching requirements of two navigation systems (i.e. NAV/GPS, NAV1\NAV2) sharing a common NAV system indicator.

Switching control for the RS08 comes from an external switch, and provision is made to force the return of the system to the VOR/ILS display, if an ILS station is selected by a connected nav system.

The RS08 provides switching for FLAG, TO-FROM, and DEVIATION lines, as well as providing annunciation output to show the display status of the common indicator.

1.3 Features

Dry circuit to 2A contacts are provided for 6 poles, and 2 poles are furnished cross-linked to provide positive functional annunciator drive, with a built-in lamp dimming function (100 mA Max.) This provides the maximum possible safety margin for the pilot's mode indicator.

Glideslope/ILS interlock is provided for indicator return to ILS mode, **where allowed by local Regulatory Authorities**. Loss of power automatically returns the indicator to the primary NAV aid. The RS08 Remote Switch operates from +9 to 33 Vdc without change in interconnect.

All interconnect and relay contacts are gold plated. Relays are sealed, high vibration rated (50g shock), dry nitrogen filled units. Circuit boards are constructed of G10-FR (flame-retardant) material, with solder masks, reflowed tin plating, and environmental post-coating.

1.4 Specifications

1.4.1 Electrical Specifications

Input Power	+9 to 33 Vdc at 100 mA Max. (Excluding lamps). Case is internally grounded.
Lamps	Type 327/387 for 28 V (40 mA). Type 330/382 for 14 V (80 mA). Maximum lamp load is 100 mA if internal dimming function is used.
Logic	Ground seeking input for switch transfer. Ground seeking ILS Enable input to return indicator to ILS mode. Will accept positive bias on this line from 5-12 V, and an external diode or transistor junction in series with the ground return.
Indicator	Dry circuit switching to accommodate standard HSI levels (500 μ A), or up to 2 A @ 28 Vdc.
Flag bias	1.0 mA, if required.
Loads	External 1 K Ω , if required.
Annunciators	Lamp circuitry provided for mode annunciation. Optional remote switch selectable dimming for 14/28V.

1.4.2 Physical Specifications

Height	1.25 inches (31.75 mm)
Depth	2.30 inches (58.42 mm) (excluding connector)
Width	4.50 inches (114.30 mm)
Mounting	Bulkhead attachment (4 x 1032/AN3)
Weight	6 oz. (168 g) (excluding mating connector)

1.4.3 Environmental Specifications

Temperature	-40 to +70°C (Ambient)
Altitude	
RS08-001	25,000 ft. max.
RS08-350	35,000 ft. max.
RS08-500	50,000 ft. max.
Humidity	95% Non-Condensing
Shock	6g (all axes)
DO-160B Env. Cat:	
RS08-001	/A1B1/BA/MNO/XXXXXXABBBBBB
RS08-350	/A1C1/BA/MNO/XXXXXXABBBBBB
RS08-500	/A1D1/BA/MNO/XXXXXXABBBBBB

1.5 Unit Nomenclature

The following list indicates the models available at the date of publication of this document. Other models may be available.

Model	Description / Distinction
RS08-001	Remote switch Interlock and lamp dimmer (2 step) Provides 6 poles of data transfer Provides 2 poles of lamp transfer 14/28 Vdc operation Gold contacts, sealed 50 g relays Includes flag bias generator Automatic ILS reversion circuit Easily cascaded for more complex installations
RS08-350	Identical to RS08-001 but qualified to 35,000 feet Suitable for mounting in unpressurized areas
RS08-500	Identical to RS08-001 but qualified to 50,000 feet Suitable for mounting in unpressurized areas

End of Section 1.0

Section 2.0 Installation

2.1 Introduction

Information in this section consists of: unpacking and inspection procedures, installation procedures, post-installation checks, and installation drawings.

2.2 Unpacking and Inspection

Unpack the equipment carefully and locate the warranty card. Inspect the unit visually for damage due to shipping and report all such claims immediately to the carrier involved. Note that each unit should have the following:

- RS08 Remote Switch
- Warranty Card
- Inspection Release

Verify that all items are present before proceeding and report any shortage immediately to your supplier.

Complete the warranty card information and send it to NAT when the installation is complete. If you fail to complete the warranty card, the warranty will be activated on date of shipment from NAT.

2.3 Installation Procedures

2.3.1 Warnings

Do not bundle any lines from this unit with transmitter coax lines. Do not bundle any logic or DC power lines from this unit with 400 Hz synchro wiring, or AC power lines.

In all installations, use shielded cable exactly as shown and ground as indicated. Significant problems may result from not following these guidelines.

2.3.2 Cable and Wiring

All unshielded wire shall be selected in accordance with AC43.13-1B Change 1, Paragraphs 11-76 through 11-78. Wire types should be to MIL-W-22759 as specified in AC43.13-1B Change 1, Paragraphs 11-85, 11-86, and listed in Table 11-11. For shielded wire applications, use Tefzel MIL-C-27500 shielded wire with solder sleeves (for shield terminations) to make the most compact and easily terminated interconnect. Follow the wiring diagrams in Section 2.6 as required.

Allow 3 inches from the end of the wire to the shield termination to allow the hood to be easily installed. Note that the hood is a "clamshell" hood and is installed after the wiring is complete.

All wiring should be at least 24 AWG, except power and ground connections which should be 20 AWG. Ensure that the ground connection is clean and well secured. To prevent system failure or inadequate equipment protection, power to each component of this system must be supplied from a separate breaker or fuse and not bundled to any other source.

2.3.3 External Switches and Lamps

2.3.3.1 Transfer Switch

The transfer switch should be a positive action (SPST or SPDT) toggle or pushbutton type, labeled as required. This switch is mandatory.

2.3.3.2 Lamp Dimmer Switch

The lamp dimmer switch should be a positive action, SPDT, toggle switch labeled DIM on one side and BRIGHT on the other. This switch is not mandatory but is highly recommended.

2.3.3.3 Lamp Test Switch

The lamp test switch should be a momentary action, DPDT, toggle or pushbutton switch labeled LT TEST. This switch is not mandatory but is highly recommended.

2.3.3.4 Annunciators

Annunciators should be selected to suit the application. Note that a single switch/lamp assembly can replace the transfer switch and annunciators. This should be a lighted pushbutton switch (SPST/SPDT) with positive action (i.e., push on, push off), and two legends to match the desired NAV functions. NAT P/N PB08-001 is recommended.

2.3.4 Post-Installation Checks

2.3.4.1 Voltage/resistance checks

Do not attach the RS08 until these conditions are met.

With the RS08 disconnected from its mating connector, check on pin 1 for +14/28 VDC relative to ground and check pin 20 for continuity to ground (below 0.5 ohms).

2.3.4.2 Power on checks

- a) Power up the ship's systems with the RS08 installed, and check that the mode annunciators transfer correctly with the appropriate switch selection. If the 'ILS Interlock' is used in the installation, check that selecting the primary NAV system to an ILS channel returns the display to the NAV/ILS mode, regardless of switch setting.
- b) Depending on the method selected for lamp dimming, ensure that operation is correct (dimmer pot or switch) and that both lamps are fully functional. The system cannot be accepted for service until all annunciators are correct.
- c) Using a ramp test set or locally broadcast navigation signal, ensure that valid data is presented on the shared indicator when in the primary NAV mode. To check, turn off the secondary NAV receiver, and ensure that there is no interaction, or cross-connected wiring. Switch the RS08 to the secondary NAV mode, and using a ramp test set or locally broadcast navigation signal, ensure that the correct presentation is provided on the shared indicator. To double check, rechannel or turn off the primary NAV receiver, and ensure that there is no interaction or cross-connected wiring.

2.4 Installation Drawings

DRAWING	REV.	DESCRIPTION	TYPE
RS08\001\302-0	1.01	Remote switch - Standard Configuration	Block Diagram
RS08\001\403-0	1.03	Remote switch - Standard Configuration	Interconnect
RS08\001\403-1	1.03	Remote switch - Installation Options	Interconnect
RS08\001\403-2	1.03	Remote switch - Master/Slave Configuration	Interconnect
RS08\001\405-0	1.01	Remote switch	Connector Map
RS08\001\521-0	1.00	Remote switch	Environmental Qual Form
RS08\001\903-0	1.03	Remote switch	Isometric
RS08\001\922-0	1.02	Remote switch	Mechanical

Section 2.0 ends after these Drawings

REVISIONS			
REV	DESCRIPTION	DATE	BY
1.01	ECR #1011 - ILS RCVR NOTED AS OPTIONAL, FORMAT CHANGES.	DEC 21/99	TAT

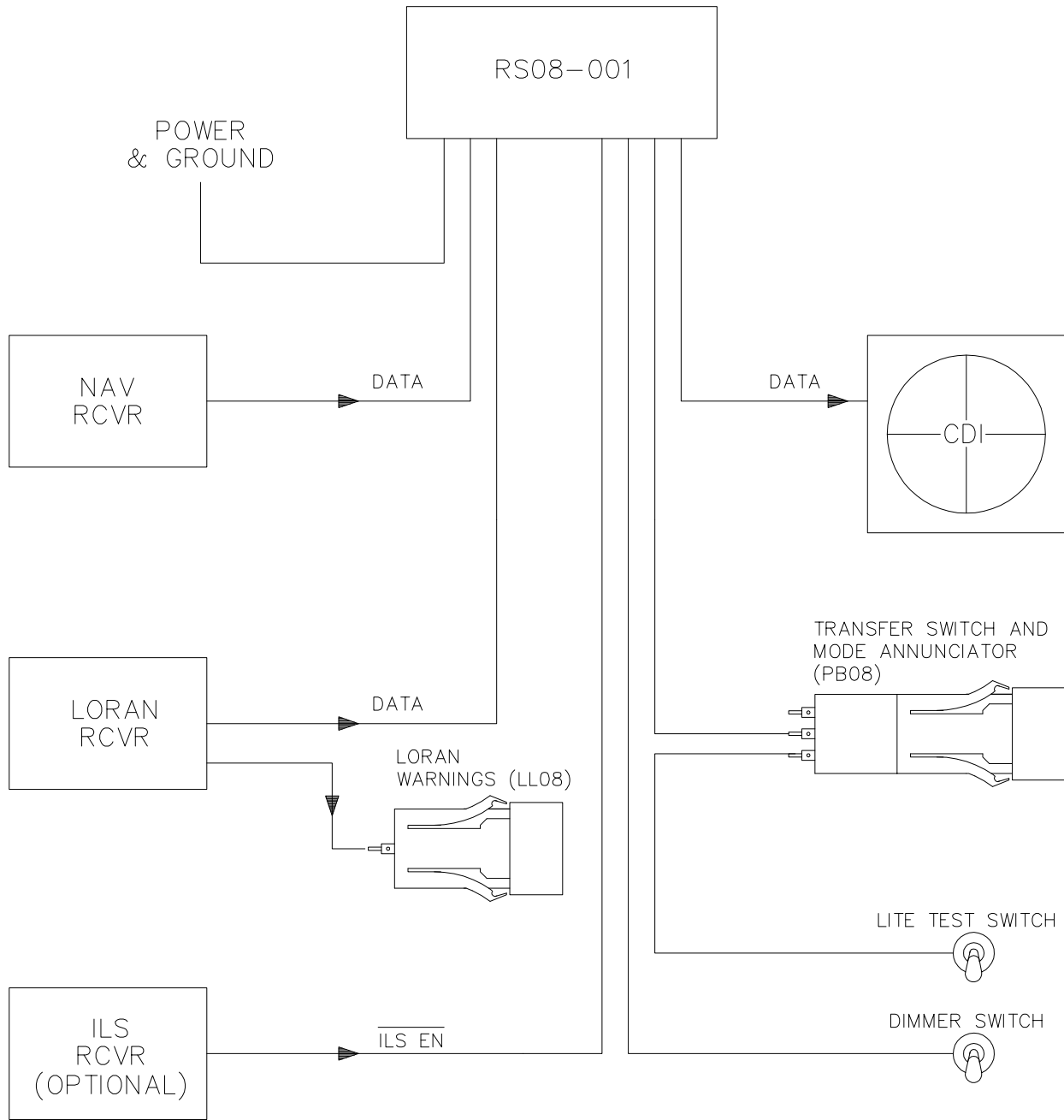

Confidential and Proprietary to NAT



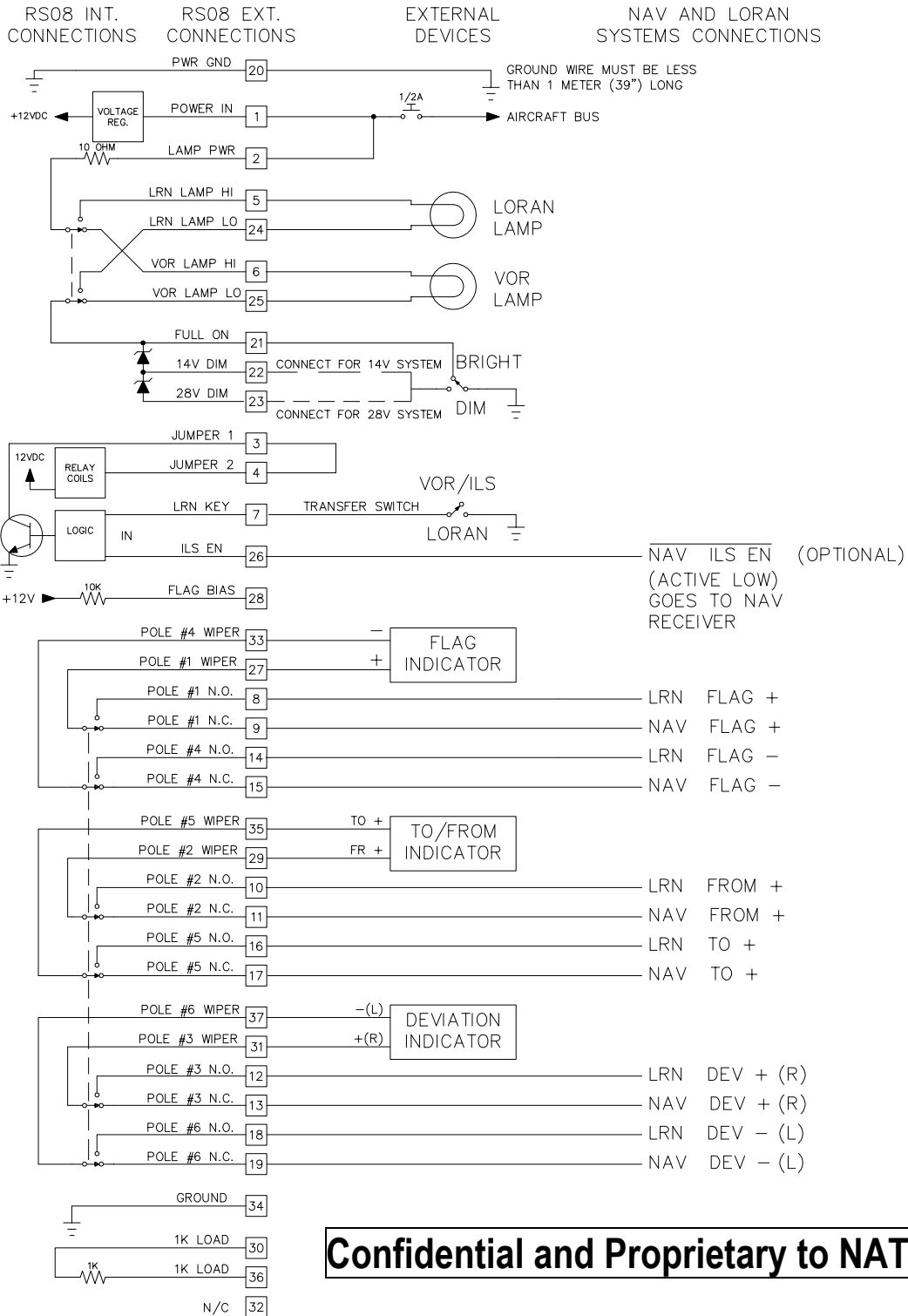

PROPRIETARY AND CONFIDENTIAL TO NAT LTD.

DESIGNED	KV	 NAT NORTHERN AIRBORNE TECHNOLOGY LTD.				
DRAWN	KV					
DATE	AUG 13/85	TITLE	8 POLE REMOTE SWITCH			
CHECKED	NAT 200	NAT 214				
APPROVED	NAT 107	SIZE	CAGE CODE	PART NO.	REV.	SHEET
FILE	302-0101.DWG	A	3AB01	RS08-001	1.01	1/1
DWG. TYPE		BLOCK DIAGRAM		DWG. NO. RS08\001\302-0		

REVISIONS			
REV	DESCRIPTION	DATE	BY
B	ADDED WIRE LENGTH NOTE, FORMAT CHANGES	JUN 8/92	MQS
1.02	NOMENCLATURE CHG'S PINS 8-19,27,29,31,33,35,37	JUL 14/95	PL
1.03	ECR #1011 - MOVED 10 OHM RES. FROM PIN 21 TO 2, NAV ILS EN NOTED AS OPTIONAL.	JAN 07/00	MWS



Confidential and Proprietary to NAT

DESIGNED	-		NORTHERN AIRBORNE TECHNOLOGY LTD.			
DRAWN	MQS		TITLE			
DATE	JUL 31/85	REMOTE SWITCH - STANDARD CONFIGURATION				
CHECKED	  	SIZE	CAGE CODE	PART NO.	REV.	SHEET
APPROVED		A	3AB01	RS08-XXX	1.03	1/1
FILE	403-0103.DWG	DWG. TYPE	INTERCONNECT	DWG. NO.	RS08\001\403-0	

REVISIONS			
REV	DESCRIPTION	DATE	BY
B	ADDED WIRE LENGTH NOTE, FORMAT CHANGES	JUN 8/92	MQS
1.02	NOMENCLATURE CHG'S PINS 8,9,14,15,27,33	JUL 21/95	PL
1.03	ECR #1011 MOVED 10 OHM RES. FROM PIN 21 TO 2	JAN 07/00	MWS

OPTIONAL LAMP TEST CONNECTIONS

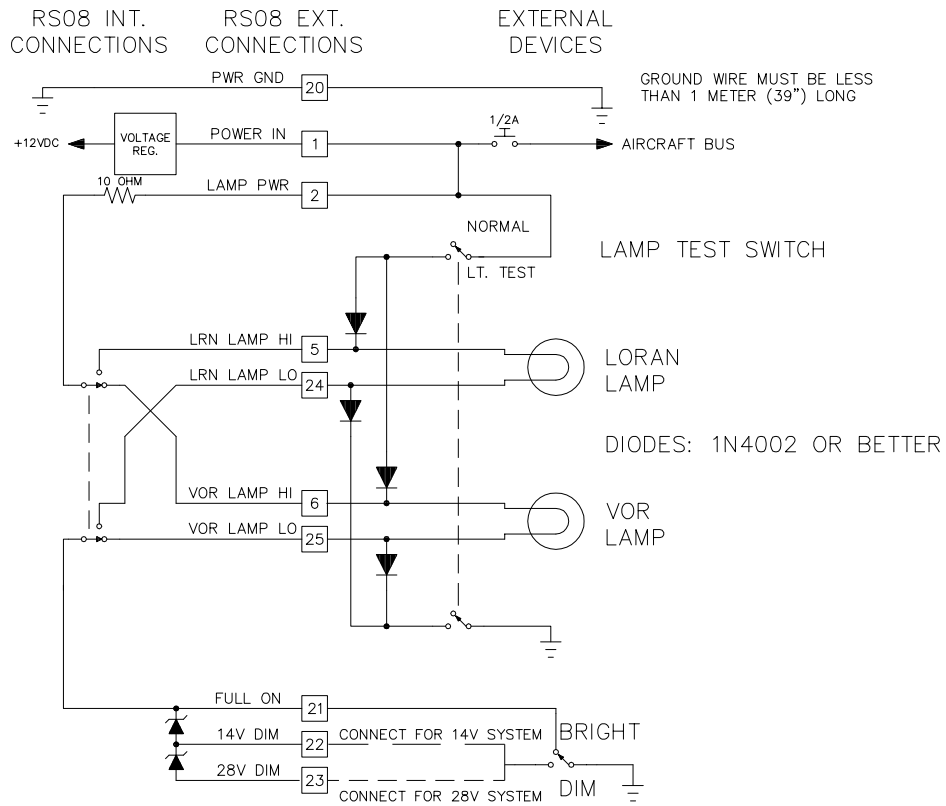

LORAN INTERFACE WITH SYSTEMS THAT OUTPUT A GROUND FOR "LORAN VALID" FLAG

NAV AND LORAN SYSTEMS CONNECTIONS

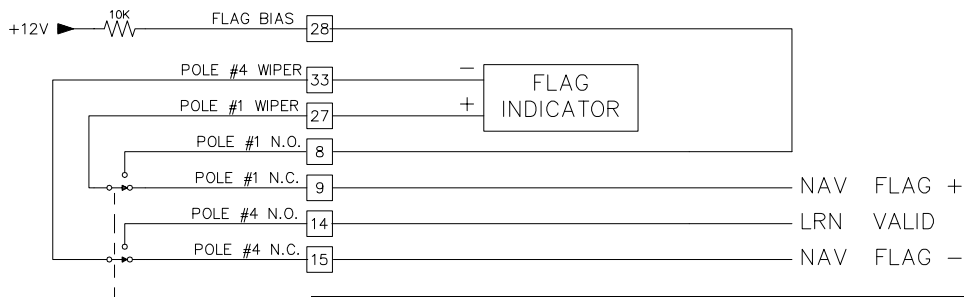

Confidential and Proprietary to NAT

DESIGNED	-	 NAT NORTHERN AIRBORNE TECHNOLOGY LTD.	
DRAWN	MQS		
DATE	AUG 13/95	TITLE	
CHECKED	NAT 214 NAT 200 NAT 104	REMOTE SWITCH - INSTALLATION OPTIONS	
APPROVED	NAT 107	SIZE A	CAGE CODE 3AB01
FILE	403-1103.DWG	PART NO. RS08-XXX	REV. 1.03
	DWG. TYPE INTERCONNECT	DWG. NO. RS08\001\403-1	SHEET 1/1

REVISIONS			
REV	DESCRIPTION	DATE	BY
B	ADDED WIRE LENGTH NOTE, FORMAT CHANGES	JUN 8/92	KV
1.02	FORMAT CHANGES ONLY	JUL 21/95	PL
1.03	ECR #1011 - MOVED 10 OHM RES. FROM PIN 21 TO 2, NAV ILS EN NOTED AS OPTIONAL.	JAN 07/00	MWS

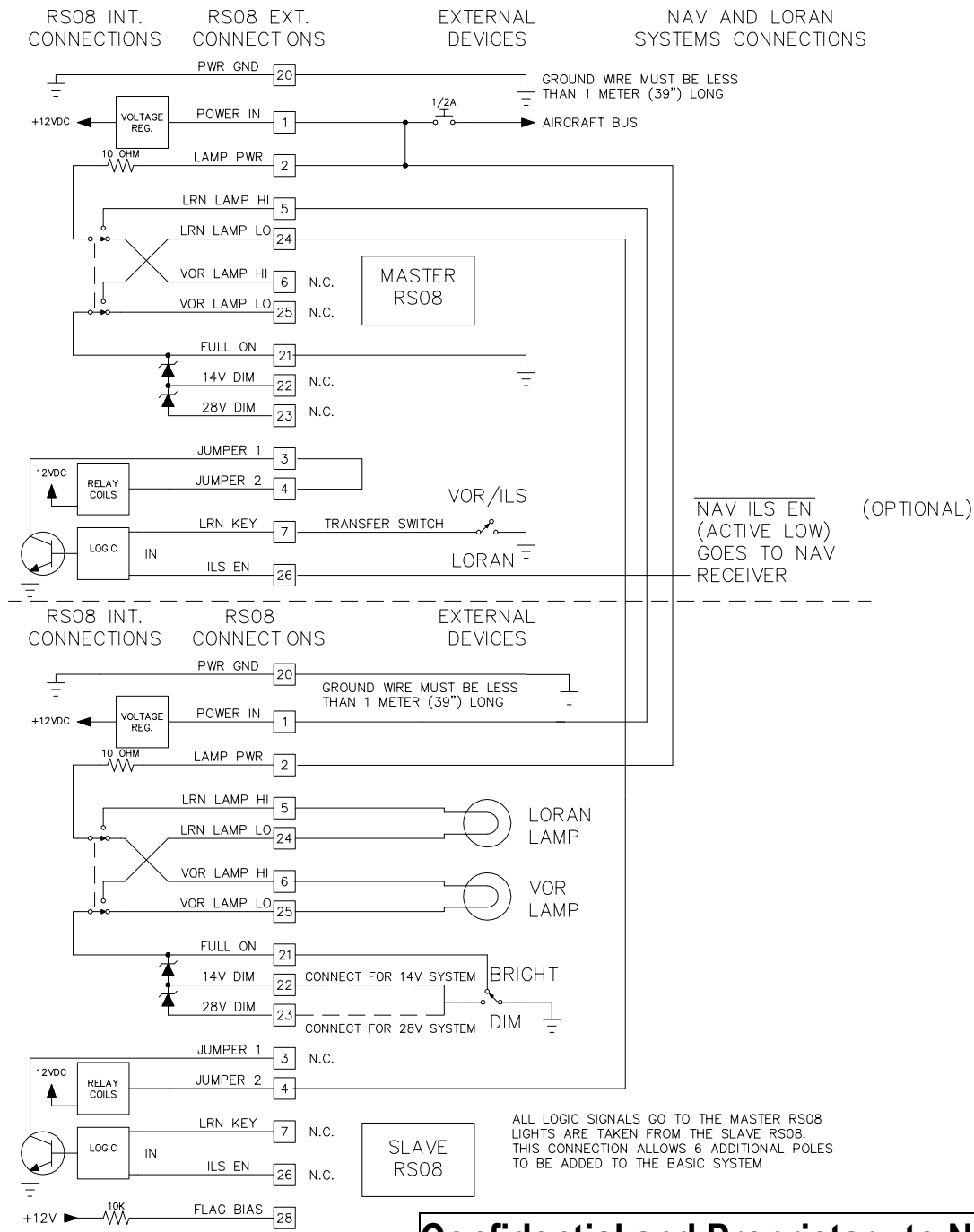

Confidential and Proprietary to NAT

DESIGNED	-		NORTHERN AIRBORNE TECHNOLOGY LTD.			
DRAWN	KV		TITLE			
DATE	AUG 12/85	REMOTE SWITCH - MASTER/SLAVE CONFIGURATION				
CHECKED	NAT 200, NAT 214, NAT 104	SIZE	CAGE CODE	PART NO.	REV.	SHEET
APPROVED	NAT 107	A	3AB01	RS08-XXX	1.03	1/1
FILE	403-2103.DWG	DWG. TYPE	INTERCONNECT	DWG. NO.	RS08\001\403-2	

J101

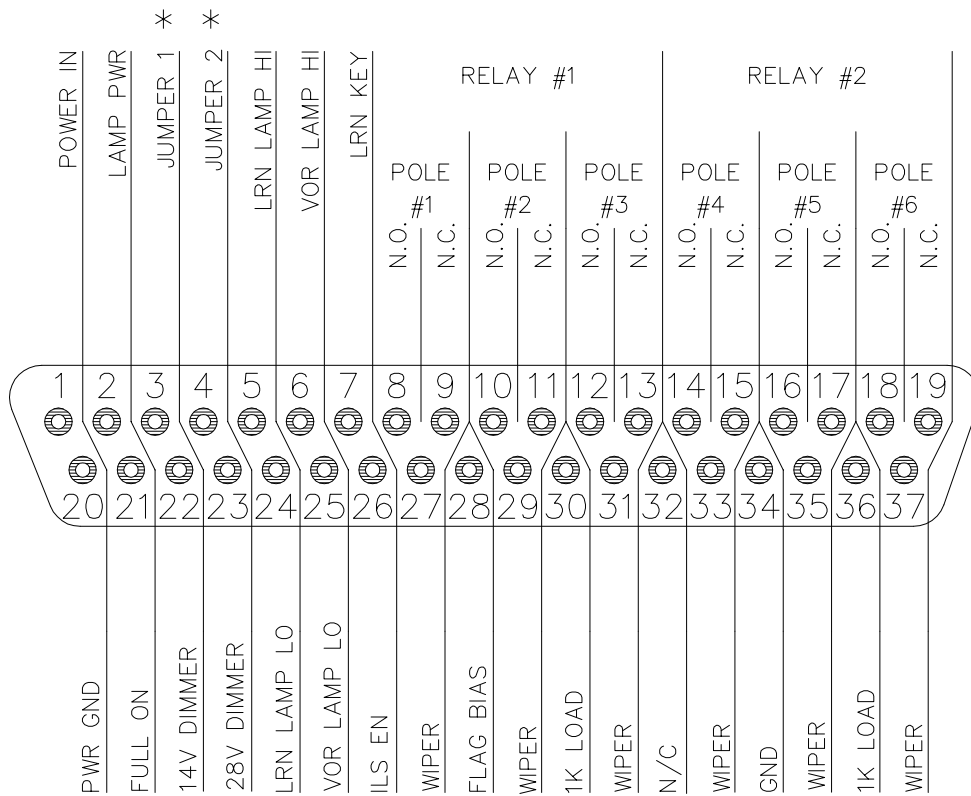

* - NORMALLY CONNECTED

POWER IN = 9-33VDC

VIEW: REAR SIDE OF AIRFRAME CONNECTOR

Confidential and Proprietary to NAT

REVISION	DATE	*nat NORTHERN AIRBORNE TECHNOLOGY LTD.			
-	AUG 09/85	DESIGNED BY	DESCRIPTION		
1.01	JUL 21/95	-	REMOTE SWITCH		
		DRAWN BY	PART NUMBER	DRAWING TYPE	SHEET
		KV/PL	RS08-XXX	CONNECTOR MAP	1/1
		APPROVED BY	DRAWING NUMBER	FILE NUMBER	
		NAT R&D	RS08\001\405-0	RS08\001\405-0101	



ENVIRONMENTAL QUALIFICATION FORM

Description: Remote Switch Document #: RS08\521-0

NAT Part #: RS08-xxx TSO #: N/A

Manufacturer's Specification and/or Other Applicable Specification: _____

TC: SCA 93-06. RTCA: DO-160B

Manufacturer: Northern Airborne Technology Ltd.

Address: #14 - 1925 Kirschner Rd., Kelowna, BC, Canada. V1Y 4N7

Prepared By: 	Checked By: 	Approved By: 
--	---	--

Conditions	DO-160B Section	Description of Conducted Tests
Temperature and Altitude	4.0	RS08-001: Equipment tested to Categories A1, B1
Low Temperature	4.5.1	RS08-350: Equipment tested to Categories A1, C1
High Temperature	4.5.2 & 4.5.3	
Altitude	4.6.1	RS08-500: Equipment tested to Categories A1, D1
Decompression	4.6.2	
Overpressure	4.6.3	
Temperature Variation	5.0	Equipment tested to Category B
Humidity	6.0	Equipment tested to Category A
Shock	7.0	Equipment tested to Section 7.2.1
Vibration	8.0	Equipment tested to Categories M, N, O
Explosion	9.0	Equipment identified as Category X no test required
Waterproofness	10.0	Equipment identified as Category X no test required

Conditions	DO-160B Section	Description of Conducted Tests
Fluids Susceptibility	11.0	Equipment identified as Category X no test required
Sand and Dust	12.0	Equipment identified as Category X no test required
Fungus	13.0	Equipment identified as Category X no test required
Salt Spray	14.0	Equipment identified as Category X no test required
Magnetic Effect	15.0	Equipment is Category A
Power input	16.0	Equipment tested to Category B
Voltage Spike	17.0	Equipment tested to Category B
Audio Frequency Susceptibility	18.0	Equipment tested to Category B
Induced Signal Susceptibility	19.0	Equipment tested to Category B
Radio Frequency Susceptibility	20.0	Equipment tested to Category B
Radio Frequency Emission	21.0	Equipment tested to Category B
Lightning Induced Transient Susceptibility	22.0	Equipment identified as Category X no test required

REMARKS

- Tests were conducted at NAT facilities in Kelowna, B.C. Canada

End of Environmental Qualification Form

REVISIONS			
REV	DESCRIPTION	DATE	BY
*	-	JUN 2/87	TGM
1.02	FORMAT CHANGES	JUL 17/95	PL
1.03	ECR #737 CHANGED CONNECTOR FROM 50 PIN	APR 2/97	MWS

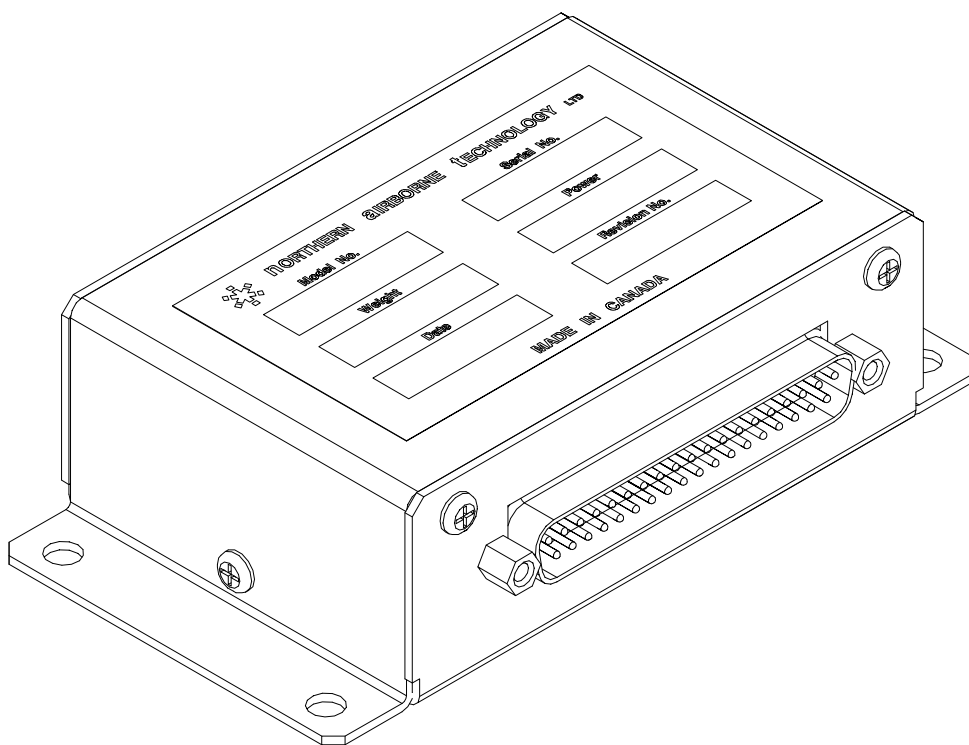

Confidential and Proprietary to NAT

DESIGNED	-	NORTHERN AIRBORNE TECHNOLOGY LTD.				
DRAWN	TGM					
DATE	AUG 12/85	TITLE REMOTE SWITCH				
CHECKED	NAT PROD. 130					
APPROVED		SIZE A	CAGE CODE 3AB01	PART NO. RS08-001	REV. 1.03	SHEET 1/1
FILE	903-0103.DWG	DWG. TYPE	3D	DWG. NO. RS08\001\903-0		

REVISIONS

REV	DESCRIPTION	DATE	BY
1.01	ECR #737 CHANGED CONNECTOR FROM 50 PIN	APR 2/97	MWS
1.02	ECR #954 - 1.80 WAS 1.91, WEIGHT ADDED.	SEP 3/97	TGM

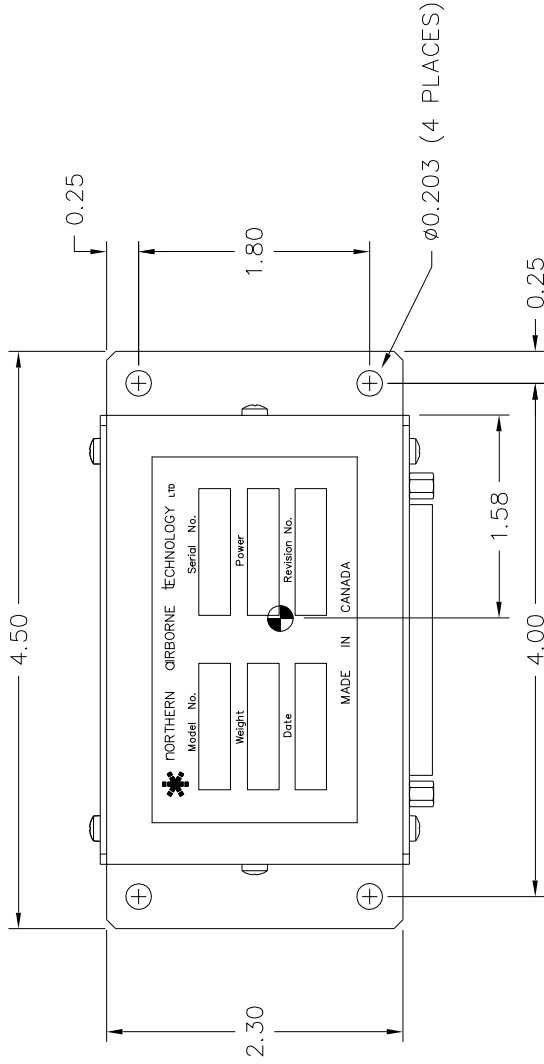

⊕ CENTER OF GRAVITY
WEIGHT 170g (0.38 lb.)

Confidential and Proprietary to NAT

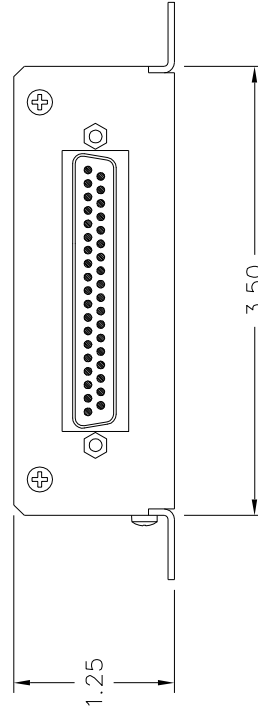
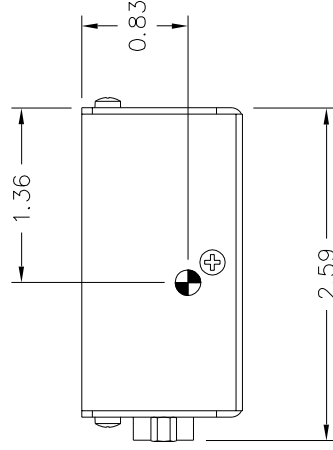

TOLERANCES UNLESS STATED OTHERWISE 0.X=+/-0.030 0.XX=+/-0.010 0.XXX=+/-0.005 0.XXXX=+/-0.002 ANGLE=+/- 0.5 DEG.	DIMENSIONS IN INCHES THIRD ANGLE PROJECTION	DESIGNED	-	TITLE	SIZE	CAGE CODE	PART NO.	REV.	SHEET
		DRAWN	TGM						
MATERIAL		DATE	AUG 2/95						
FINISH		CHECKED	NAT 209						
		APPROVED	NAT 107						
		FILE	922-0102.DWG	DWG. TYPE	MECH. INSTALLATION	DWG. NO.	RS08\001\922-0		

nat NORTHERN AIRBORNE TECHNOLOGY LTD.

Section 3.0 Operation

3.1 Introduction

Information in this section consists of the functional and operating procedures for the RS08 Remote Switch.

3.2 Mode Annunciation

A dual annunciator is provided for the pilot's reference, and indicates that the transfer has been accomplished to the selected source. Provision is also made to allow dimming of the annunciation by an external toggle switch. Because the 'ILS Interlock' can force a transfer of the system, the pilot should always take his cue from the annunciators, not the transfer switch itself. If a lighted pushbutton switch with dual legends is used, there will be no ambiguity.

3.3 NAV Selection

If at the time of installation, a NAV receiver was selected for connection to the ILS interlock, and then is channeled to an ILS station, the RS08 will return the indicator to the VOR/ILS mode irrespective of any other command. Care should be taken to not preset any such station while navigating from the secondary NAV source or the presentation will be switched back to the primary NAV system.

3.4 Annunciator Lighting

Since the annunciators must be readable in sunlight, power to these is not normally taken from the aircraft lamp dimmer circuit, which would be off during daylight flying. Instead, provision is made for a switched dimmer (full/half bright) control, to be mounted by the annunciators. If a lamp test switch has been installed, it will light both lamps at full brightness.

3.5 Fault Indications

3.5.1 Loss of Power

If power is lost to the RS08, both annunciators will be dark, and the system will return to the VOR/ILS display. The lamps will NOT test OK. The pilot should confirm correct data display by channeling the radio in question, or offsetting the radial, and checking for the correct presentation.

3.5.2 Failure Presentations

If there is an internal failure in the RS08 which causes loss of power to the relays, driver or logic failure, it will appear as one of three presentations:

The annunciator stays lit in one mode or the other, and will not transfer.

The data will likely be correct, and can easily be confirmed by pilot test of the indicated navigation system. Only one nav source will be available until the system is repaired. This can also be caused by external switch failure.

No annunciator will light. Lamps test OK.

Indicates relay failure. Do not use any navigation data, as data is likely faulty. Repair immediately.

Unit will transfer, but only one annunciator will light. Lamps test OK.

Indicates relay or wiring failure, and will probably give valid data only if the lamp lights in the VOR/ILS mode. Confirm data by pilot test, and repair immediately.

In general, the pilot should always confirm that the presentation he sees is, in fact, tied to the system he has selected. A simple radial offset or other method will greatly improve operational safety, and insure that a power failure, ILS channeled nav or other fault has not presented false navigation data on the HSI/CDI.

End of section 3.0