



**SM09-3**

**AA83-100  
InterMUSIC™ Stereo Intercom**



## **INSTALLATION AND OPERATION MANUAL**

**REV 4.00 March 4, 2005**

**Northern Airborne Technology Ltd.  
1925 Kirschner Road  
Kelowna, BC, Canada.  
V1Y 4N7**

**Telephone (250) 763-2232  
Facsimile (250) 762-3374**

**Copyright 2005 by Northern Airborne Technology**







## Table of Contents

Section	Title	Page
1	Description	
1.1	Introduction	1-1
1.2	Purpose of Equipment	1-1
1.3	Features	1-1
1.3.1	Stereo & Intercom Special Features	1-1
1.3.2	Communication Functions	1-1
1.4	Specifications	1-2
1.4.1	Electrical Specifications	1-2
1.4.2	Mechanical Specifications	1-4
1.4.3	Environmental Specifications	1-4
2	Installation	
2.1	Introduction	2-1
2.2	Unpacking and Inspection	2-1
2.2.1	Warranty	2-1
2.3	Installation Procedures	2-1
2.3.1	Warnings	2-1
2.3.2	Cautions	2-2
2.3.3	Cabling and Wiring	2-2
2.3.4	Adjustments	2-2
2.3.5	Mechanical Installation	2-3
2.3.6	Post Installation Checks	2-4
2.4	Continued Airworthiness	2-5
2.5	Accessories Supplied	2-5
2.6	Installation Drawings	2-6
3	Operation	
3.1	Introduction	3-1
3.2	General Operation	3-1
3.2.1	Stereo & Intercom Special Features	3-1
3.2.2	Communication Functions	3-1
3.2.3	Important Operating Considerations	3-1
3.2.4	Installation Adjustments	3-2
3.3	Controls and Indicators	3-2
3.3.1	ICS VOL/VOX	3-2
3.3.2	Music Vol	3-2
3.3.3	VOX Operation	3-3
3.3.4	Annunciator	3-3
3.3.5	MODE Control	3-3
3.3.6	Radio Functions	3-4
3.3.7	Muting Logic	3-4
3.3.8	Automatic Fail-safe	3-5



## Section 1 Description

### 1.1 Introduction

---

Information in this manual consists of the operational procedures and specifications for the AA83-100 InterMUSIC™ Stereo Intercom.

### 1.2 Purpose of Equipment

---

The AA83-100 is a 4-place stereo voice-activated intercom that provides full intercom capabilities for the pilot and copilot and two passengers (PAX). It provides entertainment and communication audio in full stereo to all four headsets, and transceiver control for both the pilot and co-pilot. The AA83-100 accepts stereo music input from portable entertainment units, CD players or other integrated on-board systems to produce high quality stereo headset output. The InterMUSIC™ family of stereo intercoms allows several installation configurations - from single unit systems, to fully independent stations for the pilot, copilot and passengers. For expanded systems, tie line connections are compatible with other NAT systems including AA82, AMS4x and AA9x series units.

### 1.3 Features

---

#### 1.3.1 Stereo & Intercom Special Features

---

The stereo music audio is muted during transmit or intercom operation and when radio receive audio is detected, permitting greater intelligibility of incoming transmissions. The AA83-100 muting depth adjustment ranges from complete music muting to gentle background music on command, with a fast attack and slow level return for optimum user comfort. Each microphone is individually gated, for the best possible noise performance during VOX operation. A front panel annunciator allows easy visual setting of the VOX threshold, and also indicates transmit operation.

#### 1.3.2 Communication Functions

---

The AA83-100 provides full boom-mic transmit and ICS functions for the pilot and copilot, and provides ICS and radio monitor operation for two additional passengers. Pilot priority on transmit and pilot isolation (direct connection to the aircraft radio system) are standard features on all NAT intercom systems. The AA83-100 can support PTT ICS operation for all users, and can be wired to cyclic/yoke switches for both TX and ICS functions.

## 1.4 Specifications

### 1.4.1 Electrical Specifications

<u>Input Power</u>	Linear regulator with over voltage protection.
Operating Voltages	
Nominal	27.5 or 13.8 Vdc @ 550 mA max (one input for both)
Maximum	30.3 Vdc
Minimum	11.0 Vdc
Internal supply	11 Vdc
<u>Input Signals</u>	
Microphone	
Quantity	4 (pilot, copilot, 2 Passengers).
Rated level	250 mVrms nominal (125 to 500 mVrms)
Impedance	150 Ohm $\pm 10\%$
Circuitry type	unbalanced
TX Keyline	
Quantity	2 (pilot, copilot).
Rated level	ground activates keyline, <20 mA source current
ICS Keyline	
Quantity	4 (pilot, copilot, 2 Passengers).
Rated level	ground activates keyline, <1 mA source current
Receive Audio	
Quantity	1
Rated level	2.5 Vrms nominal (1.3 to 5.0 Vrms)
Impedance	1.2 kOhm $\pm 20\%$
Circuitry type	unbalanced
Music Inputs	
Quantity	2 (left channel, right channel)
Rated level	1.4 Vrms nominal (850 mVrms to 2.4 Vrms)
Impedance	12.5 kOhm $\pm 10\%$
Circuitry type	unbalanced
<u>Bidirectional Signals</u>	
ICS TIE Channel	
Quantity	1
Rated level	340 mVrms nominal (170 to 680 mVrms)
Impedance	2 kOhm $\pm 10\%$
Circuitry type	unbalanced

Output Signals

## Phones

Quantity	4 (pilot, copilot, 2 Passengers)
Rated level	>5.5 Vrms (>100 mW; RX, ICS and Music)
Impedance	300 Ohm $\pm 10\%$
Circuitry type	transformer, unbalanced

## Radio TX Mic

Quantity	1
Rated level	250 mVrms $\pm 10\%$
Impedance	150 Ohm nominal
Circuitry type	direct throughline via relay

## Radio TX Keyline

Quantity	1
Rated level	<1 A
Circuitry type	grounded relay contact

Audio Performance

As per RTCA DO-170 except where noted. Product Classification 1a

Full Output Power	100 mW min into 300 $\Omega$ (each stereo channel)
Audio frequency response	
Receive	<3dB down from 350 - 6000 Hz
Intercom	<3dB down from 350 - 3000 Hz
ICS Tie	<3dB down from 350 - 3000 Hz
Music	<3dB down from 300 - 15000 Hz (Music Bass control at mid setting)
Distortion	<10%, <3 % typical (350 to 6000 Hz)
Input - Input crosstalk	-50 dB max*
Input - Output crosstalk	-55 dB max
Input - Mic crosstalk	<1.0 mVrms*
Audio noise	-50 dB max
Output Regulation	$\leq 3$ dB variance (350 to 6000 Hz)
Audio Communication	Loud & Clear
ICS Volume controls	>35 dB*, 40 dB nominal
Music Volume controls	>35 dB*, 40 dB nominal
Stability and Short Circuit Protection	No spurious or sustained oscillations.
Receive Input impedance	1.2 k $\Omega$ $\pm 20$ %
Mic Input impedance	150 $\Omega$ $\pm 10$ %
Music Input impedance	12.5 k $\Omega$ $\pm 10$ %
Tie Line	2 k $\Omega$ $\pm 10$ %

\* Manufacturer specification

### Miscellaneous Audio Performance

ICS BAL control	≥20 dB dynamic range
MUSIC BAL control	≥20 dB dynamic range
RX BAL control	≥20 dB dynamic range
ICS BASS control	±2.5 dB min. range at 350 Hz*
MUSIC BASS control	±2.5 dB min. range at 350 Hz*
MUSIC MUTE control	-60 dB to -10 dB
RX VOL control	≥35 dB dynamic range
Music attack/decay time	<7 seconds

\* measured at -10 dB ref: rated input level

### **1.4.2 Mechanical Specifications**

Height	1.32" (33.5 mm) max.
Depth	7.20" (182.9 mm) max. total 5.84" (148.3 mm) max. depth behind panel
Width	2.62" (66.5 mm) max, panel width
Weight	0.70 lb (0.32 kg) max
Mounting	Through front panel; three 6-32 black brass screws. Aircraft panel thickness 0.050" to 0.125"
Faceplate	Double-sided photo-imaged 0.062" aluminum plate, 1.3" x 2.6"
Material/Finish	Chassis/Cover: Brushed aluminum with chromate conversion
Connectors	One 44 pin male high-density D-min connector with jackposts
Installation Kit	AA83-100-IKC

### **1.4.3 Environmental Specifications**

Temperature	-20 °C to +55 °C
Altitude	50 000 ft.
Shock	6g/11ms, 20g/11ms, 20g/3s sustained.

#### Qualification:

DO-160D Env. Cat. [(A1)(D1)X]BXB[(SMB)(UF)]XXXXXXZBAXXXMXXXX  
Safety of Flight requirements per RTCA/DO-160D Environmental Conditions.

End of section 1

## Section 2 Installation

### 2.1 Introduction

---

Information in this section consists of: unpacking and inspection procedures, installation procedures, post-installation checks, and installation drawings.

### 2.2 Unpacking and Inspection

---

Unpack the equipment carefully and locate the warranty card. Inspect the unit visually for damage due to shipping and report all such claims immediately to the carrier involved. Note that each unit should have the following:

- AA83-100 InterMUSIC™ Stereo Intercom
- Installation kit (see section 2.5)
- Warranty Card
- Operator's Manual
- Release certification

Verify that all items are present before proceeding and report any shortage immediately to your supplier.

#### 2.2.1 Warranty

---

Complete the warranty card information and send it to NAT when the installation is complete. If you fail to complete the warranty card, the warranty will be activated on date of shipment from NAT.

**Note:** An appropriately rated facility, e.g. Certified Aircraft Repair Station, must install this equipment in accordance with applicable regulations. NAT Ltd's warranty is not valid unless the equipment is installed by an authorized NAT Dealer. Failure to follow any of the installation instructions, or installation by a non-certified individual or agency will void the warranty, and may result in a non-airworthy installation.

### 2.3 Installation Procedures

---

#### 2.3.1 Warnings

---

Do not bundle **any lines from this unit** with transmitter coax lines. Do not bundle any logic, audio, or DC power lines from this unit with 400 Hz synchro wiring or AC power lines. Do not position this unit next to any device with a strong alternating magnetic field such as an inverter, motor or blower, or significant audio interference will result.

### 2.3.2 Cautions

---

In all installations, use shielded cable exactly as shown and **ground as indicated**. Significant problems may result from not following these guidelines.

All audio installations can be seriously degraded by incorrect wiring and shielding, and may result in abnormal cross-talk, hum and ground-loop noise. Be especially careful with all microphone wiring and Tie Line wiring, as these lines carry the lowest level signals in the aircraft.

All microphone and headset jacks should be electrically isolated from the airframe or significant ground loop noise may result.

### 2.3.3 Cabling and Wiring

---

All unshielded wire should be MIL-W-22759 or equivalent. For shielded wire applications, use Tefzel MIL-C-27500 shielded wire with solder sleeves (for shield terminations) to make the most compact and easily terminated interconnect. Follow the wiring diagrams in Section 2.6 as required.

Allow 3 inches from the end of the wire to the shield termination to allow the hood to be easily installed. Note that the hood is a 'clamshell' hood, and is installed after the wiring is complete. Aircraft harnessing should permit the unit to be lowered from the panel for easy access to all side adjustments. Do NOT mount the unit until all adjustments have been carried out.

All wiring should be at least 22 AWG. Ensure that all ground connections are clean and well secured, and that they share no path with any electrically noisy aircraft accessories such as blowers, turn and bank instruments or similar loads. Power to this unit must be supplied from a separate breaker (1 A) or fuse (1 A fast), and not attached to any other existing breaker without additional protection. The correct fuse is included with the AA83.

Ensure that all ground connections are clean and well secured.

### 2.3.4 Adjustments

---

The unit ships from the factory with all internal adjustments set to the normal test levels. Once installed in the aircraft, it may be desirable to change some of these settings to best suit the local operating environment.

**CAUTION**

Before performing the following adjustments ensure the aircraft radio's volume control is set to produce 2.5 Vrms  $\pm 10\%$  at the input to the AA83-100, or the mute functions may not operate correctly.

The internal adjustments are located along the sides of the unit and are as follows:



#### 2.3.4.1 ICS, RX, and MUSIC BAL.

These potentiometers are used to adjust the headset stereo balance.

#### 2.3.4.2 ICS and MUSIC BASS

These potentiometers are used to adjust the amount of bass audio to the headsets. Rotating ccw will lower the bass level, and cw will raise it.

#### 2.3.4.3 RX VOL

To reduce the receive audio volume, rotate this potentiometer ccw, and to increase the volume, rotate it cw.

#### 2.3.4.4 MUSIC MUTE

The music mute level can be adjusted using this potentiometer.

### 2.3.5 Mechanical Installation

The AA83-100 can be installed in a vertical or horizontal attitude directly on the instrument console, using the AA83-100-IKC Installation kit (see Section 2.5 for details).

**Before the unit is mounted**, make all functional tests and trimpot adjustments. Be sure the harness has enough clearance to permit the unit to be dropped down for re-adjustment, if needed later. Make sure unit is securely fastened to the panel, and that the connector locks are tightened **before any flight is attempted**.

For proper installation, refer to **Mounting Diagram** (AA83\100\920-0) and **Drill Template** (AA83\001\921-0) and the following steps:

**Note:** The mounting nuts on the panel pots should not be removed at any time.

- a) After deciding the attitude (vertical or horizontal) of the unit, drill the required mounting holes in the aircraft panel and insert the AA83-100 from behind the panel.
- b) Remove the protective plastic film from the black metal faceplate, and position it with the appropriate legend orientation facing out. Secure with the mounting screws provided.

**Note:** Ensure that the aircraft panel is tightly 'sandwiched' between the AA83-100 and faceplate.

- c) Rotate the inner and outer shafts of the ICS VOL / VOX potentiometer fully ccw. The outer knob may be rotated by hand, but it may be necessary to temporarily attach the inner ICS knob to facilitate this action. Align the white markers on the knobs (part of 40-21-ICS3) to the LIVE position on the faceplate label. Using a 0.05" Allen key, tighten the knobs onto the potentiometer shafts.
- d) Rotate the shaft of the MUSIC VOL potentiometer fully ccw. Align the white marker on the knob (part of 40-18-MUS2) to the MIN position on the faceplate label. Using a 0.05" Allen key, tighten the knob onto the potentiometer shaft.

**Note:** Make sure there is enough clearance between the concentric knobs so that rotating one does not also move the other. A piece of paper makes a good spacer when setting up the clearance.

### 2.3.6 Post-Installation Checks

---

If any preset requires adjustment, be sure this is carried out before the aircraft leaves, and that the unit and its mating connector are secured before departure. Make all required log book entries, electrical load, weight and balance amendments and other paperwork as required by your local regulatory agency.

#### 2.3.6.1 Voltage/resistance checks

**Do not attach the AA83-100 until the following conditions are met.**

Check the following:

- a) Check P101, pin <1> for +12 to +28 Vdc relative to ground.
- b) Check P101, pin <16> for continuity to ground (less than 0.5  $\Omega$ ).
- c) Check P101, pins <11> and <12> for continuity to ground (less than 0.5  $\Omega$ ) when the relevant ICS switch is keyed.
- d) Check all mic, phone, music, and key lines for shorts to ground or adjacent pins. Check all key lines for correct operation.

#### 2.3.6.2 Power On checks

Install the AA83-100 and power up the aircraft's systems, and turn on the radios and accessories required. Verify normal operation of all functions. Refer to Section 3 for specific operation details.

- a) Begin with only the pilot's headset installed, no hand mic. Check for correct radio operation (both receive and transmit) and ICS operation. Check yoke (or cyclic) switch action.
- b) If there is a music source in the system turn it on and verify that music is heard in all modes except PLT ISO. Check for proper mute operation.

**Note:** Unusual buzzes, hums or other background audio may be symptomatic of multiple grounds or noisy external systems sharing the same wire bundle. Incorrect jack wiring is a common fault, especially for passenger stations, and may cause loss of audio, a tone on the headset lines, or other problems.

- c) Plug in the copilot's headset. Check for correct radio and ICS operation. Check pilot's transmit priority. Check yoke or cyclic switch functions, if applicable.
- d) Plug in the hand mic (if applicable to the installation), and test for correct operation in all modes. It must activate the transmitter(s) in all cases.
- e) Plug in any remaining headsets, and check for correct ICS operation.
- f) To verify proper operation, all functions and levels should be checked in-flight.

Be sure headsets are of good quality and are installed correctly. Unless the AA83 has specifically been wired for mono operation **NEVER USE MONO AIRCRAFT HEADSETS** in the system, as they will short out one side of the AA83 power amplifier when installed in stereo jacks. This may result in eventual unit failure, which IS NOT COVERED BY WARRANTY.

**Upon satisfactory completion of all performance checks, make the required log entries and complete the necessary Regulatory Agency paperwork before releasing the aircraft for service.**

## 2.4 Continued Airworthiness

Maintenance of the AA83-100 is 'on condition' only. Periodic maintenance of this product is not required.

## 2.5 Accessories Supplied

Installation kit p/n AA83-100-IKC (crimp) is required to complete the installation. The kit consists of the following:

Quantity	Description	NAT Part #
1	D-sub Socket	20-20-044
44	Contacts	20-26-703
1	Jackscrew, D-sub, Pair	20-27-002
1	Hood, D-sub, Plastic	20-29-026
1	AGC, Fast, 1 A	23-00-006
3	Screw, panhead, Phillips, Brass, Black	25-11-427
1	Knob, Fluted Concentric, Rubber	40-21-ICS3
1	Knob, Printed Fluted, Rubber, Music	40-18-MUS2
1	Legend and Template, AA83	43-10-083
1	Faceplate, Rectangular, AA83-100	50-04-832

## 2.6 Installation Drawings

DRAWING	REV.	DESCRIPTION	TYPE	SERIAL #
AA83\100\403-0	1.00	Stereo Intercom	Interconnect	2351 and up
AA83\100\405-0	1.00	Stereo Intercom	Connector Map	2351 and up
AA83\100\905-0	1.00	Stereo Intercom	Faceplate	2351 and up
AA83\100\920-0	1.00	Stereo Intercom	Mounting Diagram	2351 and up
AA83\001\921-0	1.00	Drill Template	Drill Template	2351 and up
AA83\100\922-0	1.00	Stereo Intercom	Mech. Installation	2351 and up

Section 2 ends after these Drawings

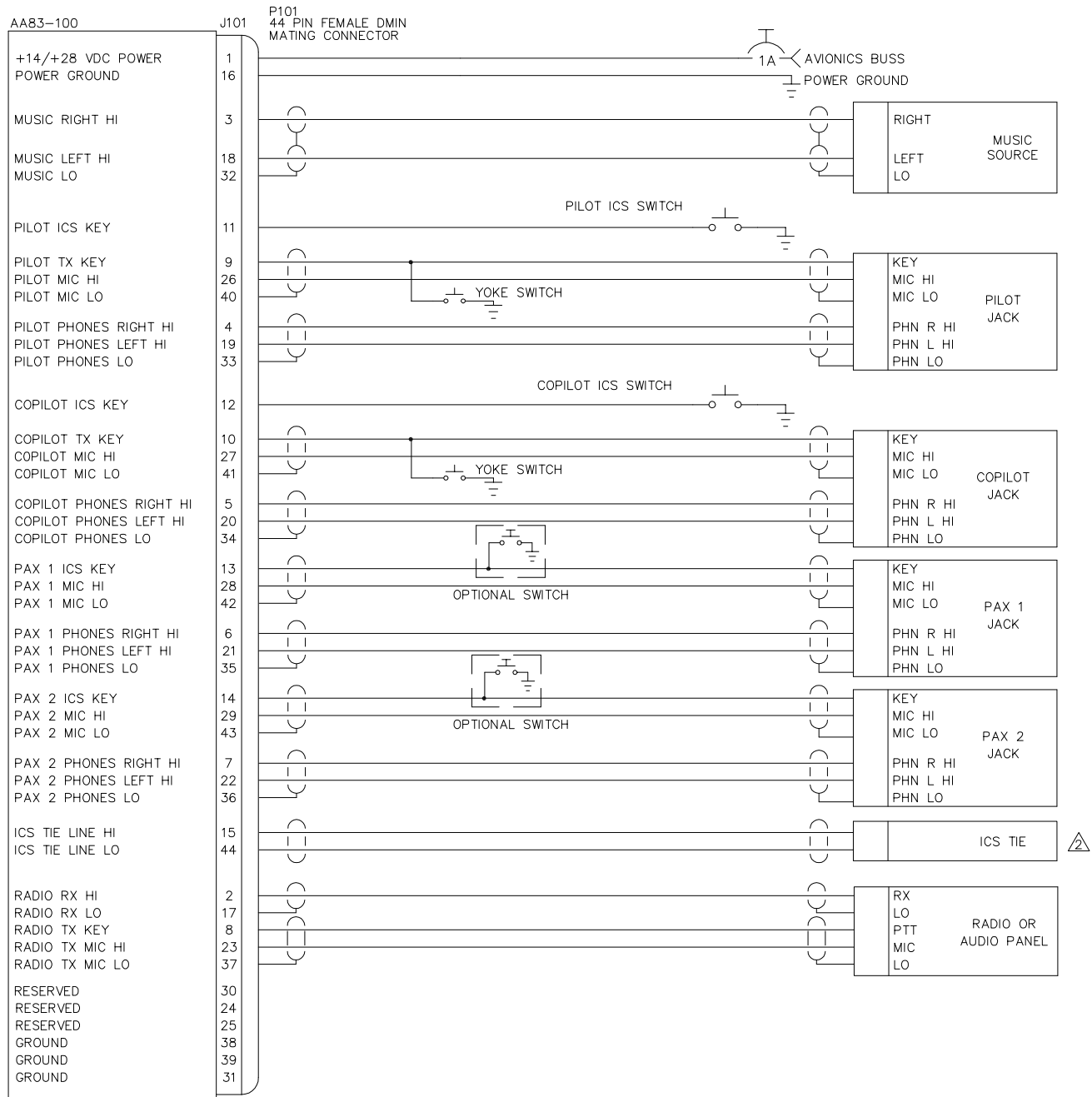

**NOTES:**

- ALL WIRES SHOULD BE 22 AWG UNLESS OTHERWISE SPECIFIED. ALL WIRE SHOULD BE IN ACCORDANCE WITH MIL-W-22759. ALL SHIELDED WIRE/CABLE SHOULD BE IN ACCORDANCE WITH MIL-C-27500.
- ⚠️ TO BE USED ONLY FOR EXPANSION OF INTERCOM SYSTEM. REFER TO INSTALLATION MANUAL FOR DETAILS.

**DEFINITIONS:**

**RESERVED:**

MAY BE CONNECTED AND USED IN FUTURE. THE CIRCUITRY MAY BE PRESENT OR ADDED TO ACTIVATE THE FUNCTION. THE PIN MAY BE USED FOR TEST PURPOSES. THERE IS NO EXTERNAL CONNECTION.

CONFIDENTIAL AND PROPRIETARY TO NAT LTD.

DESIGNED	KEH	 <b>NAT</b> NORTHERN AIRBORNE TECHNOLOGY LTD.	TITLE <b>STEREO INTERCOM</b>			
DRAWN	TAT					
DATE	OCT 6/03					
CHECKED	<b>NAT 201</b>   <b>NAT 255</b>	PART NO. <b>AA83-100</b>				
APPROVED	<b>NAT 114</b>					SIZE <b>A</b>
FILE	403-0.DWG	DWG. TYPE <b>INTERCONNECT</b>	DWG. NO. <b>AA83\100\403-0</b>			



P101  
 44 PIN FEMALE DMIN  
 MATING CONNECTOR

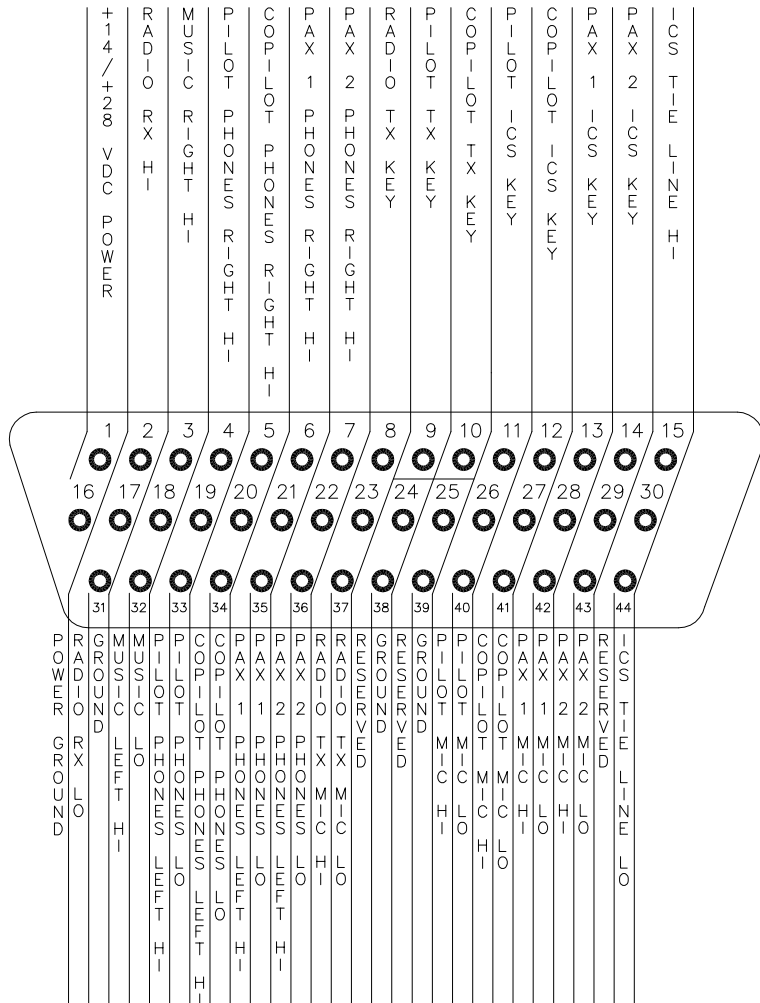

VIEW IS FROM REAR OF AIRFRAME CONNECTOR

CONFIDENTIAL AND PROPRIETARY TO NAT LTD.

DESIGNED	KEH	<b>NAT</b> NORTHERN AIRBORNE TECHNOLOGY LTD.				
DRAWN	TAT					
DATE	NOV 28/03	TITLE STEREO INTERCOM				
CHECKED	<span style="border: 1px solid black; padding: 2px;">NAT 249</span>					
APPROVED	<span style="border: 1px solid black; border-radius: 50%; padding: 5px;">NAT 114</span>	SIZE A	CAGE CODE 3AB01	PART NO. AA83-100	REV. 1.00	SHEET 1/1
FILE	405-0.DWG	DWG. TYPE	CONNECTOR MAP	DWG. NO.	AA83\100\405-0	



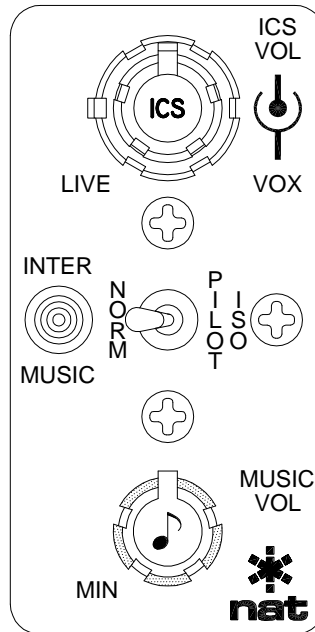
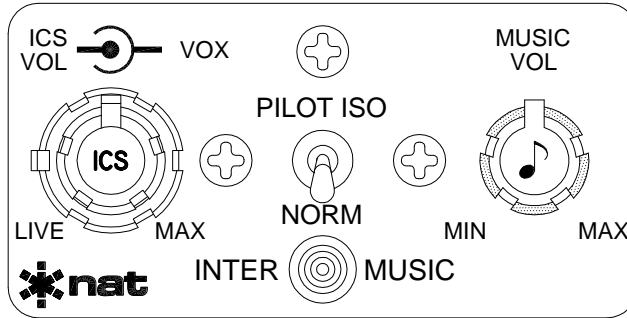

CONFIDENTIAL AND PROPRIETARY TO NAT LTD.

DESIGNED	KH		<b>NAT</b> NORTHERN AIRBORNE TECHNOLOGY LTD.				
DRAWN	TAT						
DATE	FEB 24/04		TITLE				
CHECKED	NAT 201	NAT 249	STEREO INTERCOM				
APPROVED							SIZE
FILE	905-0.DWG	DWG. TYPE	A	3AB01	AA83-100	1.00	1/1
				FACEPLATE	DWG. NO.	AA83\100\905-0	



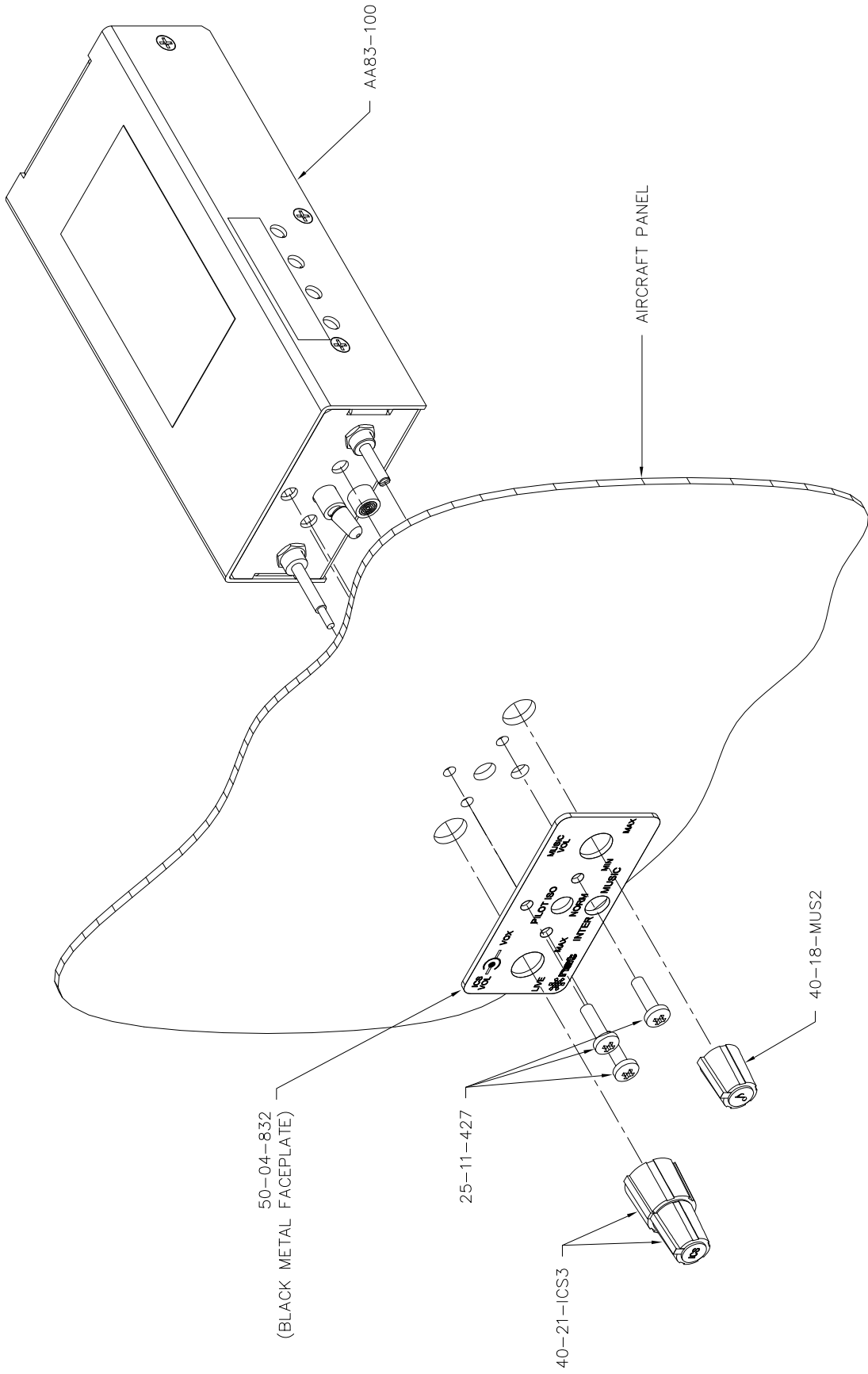

CONFIDENTIAL AND PROPRIETARY TO NAT LTD.

DESIGNED	KEH				
DRAWN	TAT				
DATE	FEB 2/04	TITLE			
CHECKED	NAT	STEREO INTERCOM			
	201				
APPROVED	NAT	SIZE	CAGE CODE	PART NO.	REV.
	114	A	3AB01	AA83-100	1.00
FILE	920-0.DWG	DWG. TYPE	MOUNTING DIAGRAM	DWG. NO.	AA83\100\920-0

**nat** NORTHERN AIRBORNE TECHNOLOGY LTD.



# AA83-001 DRILL TEMPLATE

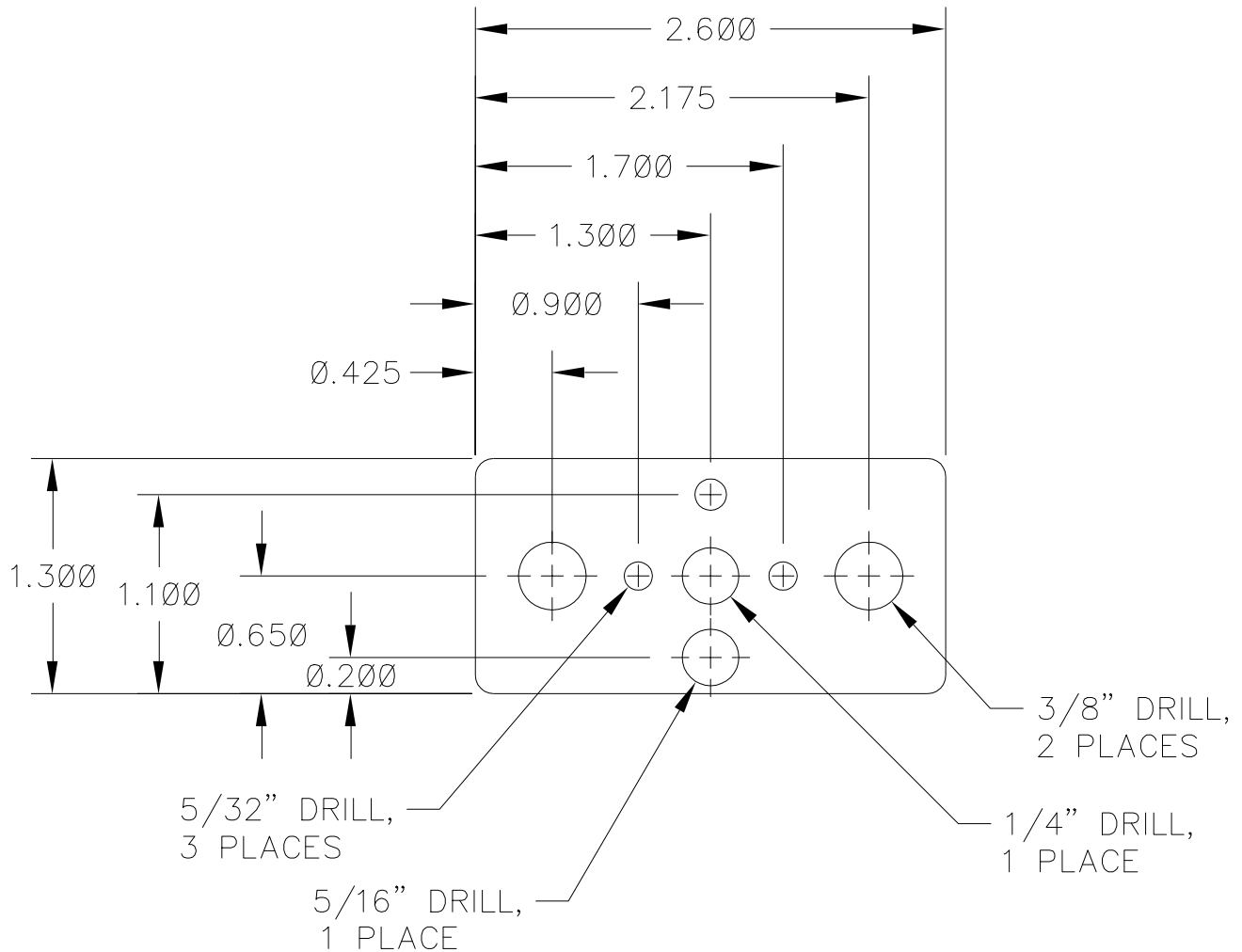

NOTE: ALL TOLERANCES  $\pm 0.01$

**Confidential and Proprietary to NAT**

REVISION	DATE	TOLERANCES UNLESS STATED OTHERWISE	<b>*nat</b> NORTHERN AIRBORNE TECHNOLOGY LTD.			
1.00	MAY 18/94	0.X=+/-0.030 DIM. IN INCHES 0.XX=+/-0.010 0.XXX=+/-0.005 0.XXXX=+/-0.0005 ANGLE=+/- 0.5 DEG.	DESIGNED BY	DESCRIPTION		
			K.V.	DRILL TEMPLATE		
			DRAWN BY	PART NUMBER	DRAWING TYPE	SHEET
			T. MASTERS	AA83-001	MOUNTING PLATE	1/1
THIRD ANGLE PROJECTION		MATERIAL/FINISH	APPROVED BY	DRAWING NUMBER		FILE NUMBER
			<b>NAT R&amp;D</b> 101	AA83-001\921-0	AA83-001\921-0100	



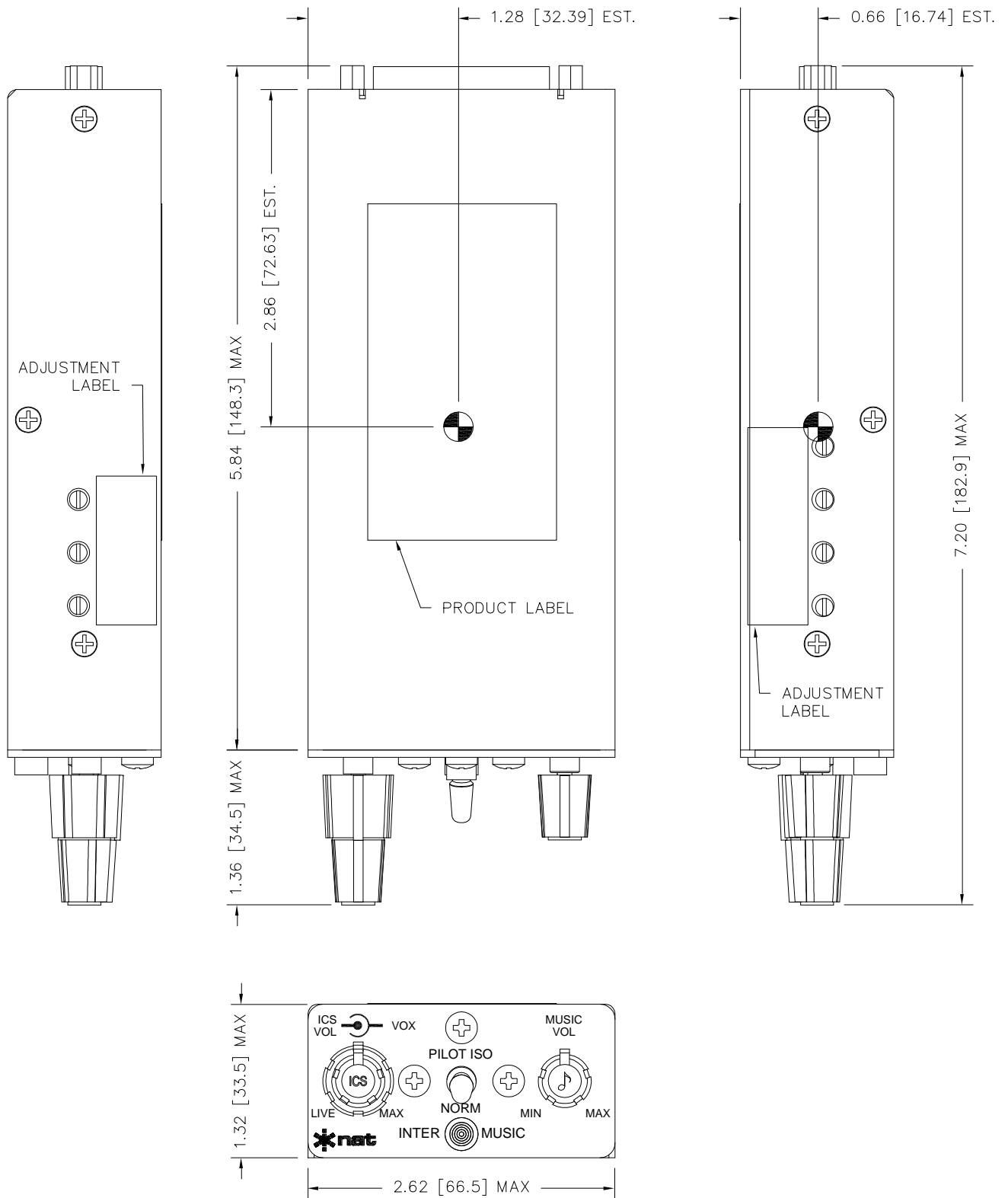

NOTES:  
 1. DIMENSIONING AND TOLERANCING  
 IN ACCORDANCE WITH ASME Y14.5M-1994

CONFIDENTIAL AND PROPRIETARY TO NAT LTD.

DIMENSIONS ARE INCHES [mm]		DESIGNED KEH	NORTHERN AIRBORNE TECHNOLOGY LTD.				
THIRD ANGLE PROJECTION		DRAWN TAT					
MASS: 0.70 lbs. (0.32 Kg) MAX		DATE NOV 19/03	TITLE STEREO INTERCOM				
MATERIAL:		CHECKED NAT 201 NAT 249	SIZE A	CAGE CODE 3AB01	PART NO. AA83-100	REV. 1.00	SHEET 1/1
FINISH:		APPROVED 	FILE 922-0.DWG	DWG. TYPE MECH. INSTALLATION	DWG. NO. AA83\100\922-0		



## Section 3 Operation

### 3.1 Introduction

Information in this manual consists of the functional and operational procedures for the AA83-100 InterMUSIC™ Stereo Intercom.

### 3.2 General Operation

The AA83-100 is a 4-place stereo voice-activated intercom that provides full intercom capabilities for the pilot and copilot and two passengers (PAX). It provides entertainment and communication audio in full stereo to all four headsets, and transceiver control for both the pilot and co-pilot. The AA83-100 accepts stereo music input from portable entertainment units, CD players or other integrated on-board systems to produce high quality stereo headset output. The InterMUSIC™ family of stereo intercoms allows several installation configurations - from single unit systems, to fully independent stations for the pilot, copilot and passengers. For expanded systems, tie line connections are compatible with other NAT systems including AA82, AMS40 and AA95 series units.

#### 3.2.1 Stereo & Intercom Special Features

The stereo music audio is muted during transmit or intercom operation and when radio receive audio is detected, permitting greater intelligibility of incoming transmissions. The AA83-100 muting depth adjustment ranges from complete music muting to gentle background music on command, with a fast attack and slow level return for optimum user comfort. Each microphone is individually gated, for the best possible noise performance during VOX operation. A front panel annunciator allows easy visual setting of the VOX threshold, and also indicates transmit operation.

#### 3.2.2 Communication Functions

The AA83-100 provides full boom-mic transmit and ICS functions for the pilot and co-pilot, and provides ICS and radio monitor operation for two additional passengers. Pilot priority on transmit and pilot isolation (direct connection to the aircraft radio system) are standard features on all NAT intercom systems. The AA83-100 can support PTT ICS operation for all users, and can be wired to cyclic/yoke switches for both TX and ICS functions.

#### 3.2.3 Important Operating Considerations

Ensure headsets are of good quality and are installed correctly. **NEVER USE MONO AIRCRAFT HEADSETS** in this system unless the installation has been specifically wired for mono operation, as they will short out one side of the AA83-100 power amplifier when installed in stereo jacks. This may result in eventual unit failure, which IS NOT COVERED BY WARRANTY. Use **only stereo headsets** with this system, and be sure the aircraft is placarded appropriately.

### 3.2.4 Installation Adjustments

Using individual level trimpots, an approved dealer can adjust the following audio levels during service, or at the time of installation.

- Music mute level
- Music Bass level
- Music balance
- RX Balance
- RX volume level
- ICS Balance
- ICS Bass level

### 3.3 Controls and Indicators

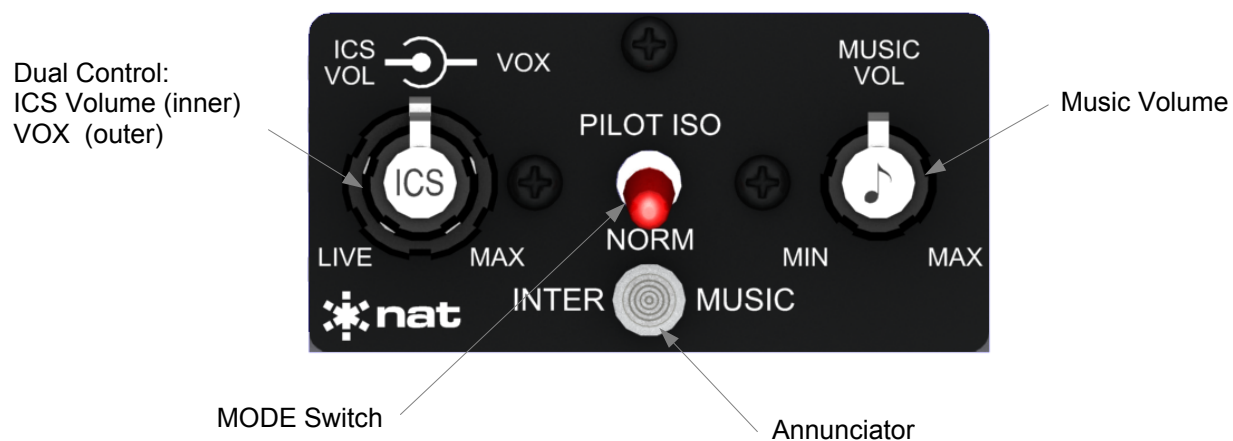

#### 3.3.1 ICS VOL/VOX

This control is a fluted concentric rubber knob on the left side of the front panel.

The inner (front) knob is the **ICS VOL** control, which is used to set Intercom volume. It is at minimum volume when fully counter-clockwise (ccw). As the knob is rotated clockwise (cw), the ICS volume for crew and PAX increases. The ICS is muted during transmit operations.

The outer (rear) knob is the **VOX** control. For full information on VOX operation, see section 3.3 below.

#### 3.3.2 Music Vol

The **MUSIC VOL** control is a fluted rubber knob on the right side of the front panel, which is used to set normal music volume. The volume can be adjusted from MIN (fully ccw) to MAX (fully cw).

### 3.3.3 VOX Operation

The VOX control is used to set the level of audio required to activate the microphones. The AA83-100 provides three modes of intercom operation, selected by the position of the VOX control.

**LIVE ICS** When the VOX control is positioned fully ccw, all mics will be live, and any sound picked up will be processed by the ICS system (hot mic).

**KEYED ICS** When the VOX control is positioned fully cw to the MAX position, the intercom will be in a keyed-only mode.

**VOX ICS** When the VOX control is positioned between fully cw and fully ccw, the intercom is in VOX mode. To establish the VOX threshold, rotate the control ccw until the LED turns red, and then rotate the control cw until the LED goes dark. Continue turning the control cw until the desired voice sensitivity is set.

### 3.3.4 Annunciator

The front panel annunciator is a bi-colour LED that shows intercom status.

If the LED is illuminated green, it indicates transmit activity, and if it is red, it indicates VOX activity. For transmit with sidetone or mic activity, it will illuminate amber. The green LED also indicates a possible stuck mic if still lit after transmission is concluded.

### 3.3.5 MODE Control



The mode control is a two-position switch used to select the operational mode of the unit. The selectable positions are PIL ISO and NORMAL. These modes are described fully in sections 3.3.5.1 and 3.3.5.2 below.

#### 3.3.5.1 NORMAL Operation

In normal use, the AA83-100 serves as a common intercommunication system for up to four users, and a flow-through interface for connection to the ship's external communication system. The NORM mode (default) permits everyone on the system to talk to each other, listen to music, and hear all radio communications.

### 3.3.5.2 PIL ISO (Pilot Isolation) Operation

In normal operation, the pilot, copilot, and passengers hear the same signals from the aircraft communication system. Sometimes this is not desirable from the pilot's perspective, for instance during communication with the tower on approach, or when discussions on the intercom would be a distraction. Many times the copilot position is simply another passenger, and the pilot may wish to be isolated from them.

**PILOT ISO** mode separates the pilot from the intercom network, allowing confidential radio communications without interference from the copilot or passenger intercom or music. The pilot has no ICS operation, and all signals are presented in mono format during this mode. All other users are unaffected and continue to use the entertainment and intercom functions of the AA83-100.

While in **PILOT ISO** mode, the pilot maintains complete control of all the radio functions of the intercom, and the pilot mic and TX keyline are directly connected to the transceiver. The copilot and passengers will be unable to monitor any transceiver activity, although they retain full ICS and music functions.

This mode is 'fail-passive', meaning that it requires no power to operate and is the same mode the box goes into *automatically when power is lost to the AA83-100*. In this way, switch over is immediate for the pilot and there is no possibility of lost communication because of a lack of pilot action. Note that the pilot's boom mic is sent directly to the radio in this mode, and only a PTT key input is needed to transmit.

**Note:** In this mode, the receive/sidetone levels may require adjustment at the audio source.

### 3.3.6 Radio Functions

There are two PTT inputs: one each for the pilot and co-pilot. Activation of either PTT input connects the user's MIC to the radio, and activates the output PTT to the radio. Sidetone is provided from the radio, not by the AA83-100.

**Note:** A priority transmission feature allows the pilot to override the copilot.

### 3.3.7 Muting Logic

When transmitting, any music will be muted quickly, and will slowly return when transmission is completed. Music will also be muted when ICS or RX functions are active. The degree of muting is set at the time of installation. The relative volume of the music can be changed from the front panel by the knob marked with a musical note.

Below is a simple chart to aid in understanding audio switching in the **NORMAL** Operation mode.

The following terms are used:

'Active' - Function being used.

'Muted' - Functions that are overridden by the active condition.

'Idle' - Functions that are not active, but still available for use.

	↓ Affect on other functions ↓				
Active feature→	Music	ICS	RX	Pilot TX	Copilot TX
Music→	<b>Active</b>	Idle	Idle	Idle	Idle
ICS→	Muted	<b>Active</b>	Idle	Idle	Idle
RX→	Muted	Idle	<b>Active</b>	Idle	Idle
Pilot TX→	Muted	Muted	Idle	<b>Active</b>	Muted
Copilot TX→	Muted	Muted	Idle	Idle	<b>Active</b>

### 3.3.8 Automatic Fail-safe

In the event of a power failure, automatic fail-safe operation will be activated. This routes the pilot's phones, mic audio, and mic PTT directly to the COM radio. Copilot and passengers will have no ICS, music, or receive functions.

The pilot mic is directly connected to the transceiver mic. Mic bias is provided by the transceiver, not the AA83-100. The pilot TX keyline is directly connected to the transceiver.

During receive mode, receive audio is directly connected from the audio source to the pilot phones, and during transmit mode, the sidetone audio is directly connected from the audio source to the pilot phones. In both cases, copilot and passengers have no ICS, music, sidetone, or receive functions.

In the unlikely event of an AA83-100 circuit failure that results in a communication problem, the automatic fail-safe mode can be enabled by pulling the AA83-100 circuit breaker.

**Note:** In Automatic Fail-Safe mode, the receive/sidetone levels may require adjustment at the audio source.

***The pilot should confirm that all aspects of Automatic Fail-Safe operation are working before accepting the aircraft into service.***

End of section 3

