

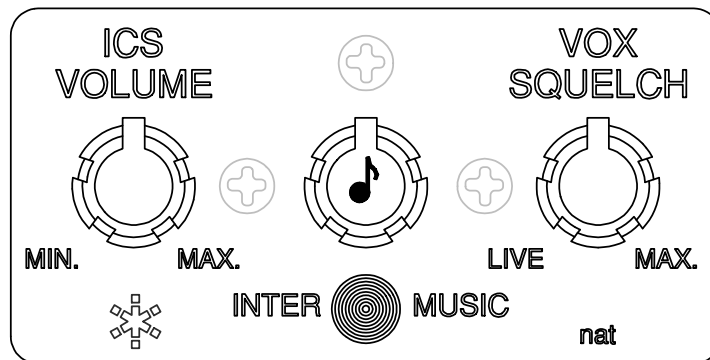

Installation and Operation Manual

AA82 InterMUSIC™ Stereo Intercom System



SM09-1

ISSUE 4.11

Northern Airborne Technology Ltd.
1925 Kirschner Road
Kelowna, BC, Canada.
V1Y 4N7
Telephone (250) 763-2232
Facsimile (250) 762-3374

Issued on the authority of Northern Airborne Technology Ltd.

Copyright 2004



AA82 InterMUSIC™ Stereo Intercom System
SM09-1 Installation and Operation Manual

Table of Contents

Section	Title	Page
1.	Description	
1.1	Introduction	1-1
1.2	Product Description	1-1
1.3	Design Features	1-1
1.4	Specifications	1-2
1.4.1	Electrical Specifications	1-2
1.4.2	Physical Specifications	1-3
1.4.3	Environmental Specifications	1-3
2.	Installation	
2.1	Introduction	2-1
2.2	Unpacking and Inspection	2-1
2.2.1	Warranty	2-1
2.3	Continued Airworthiness	2-1
2.4	Installation Procedures	2-2
2.4.1	Warnings	2-2
2.4.2	Cautions	2-2
2.4.3	Cabling and Wiring	2-2
2.4.4	Mounting	2-3
2.4.5	Post Installation Checks	2-3
2.5	Adjustments and Connections	2-3
2.5.1	Radio Settings	2-4
2.5.2	Setting Up Music and Muting	2-4
2.5.3	Setting Balance and Bass Potentiometers	2-4
2.5.4	Other ICS Functions	2-5
2.5.5	Music Selection (AA82-060 only)	2-5
2.5.6	Final Check	2-5
2.6	Accessories Required	2-6
2.7	Installation Drawings	2-7
3.	Operation	
3.1	Introduction	3-1
3.2	General Information	3-1
3.3	Controls and Indicators	3-1
3.3.1	Stereo & Intercom Special Features	3-2
3.3.2	Logic Explanation	3-2
3.3.3	Tie/Split Operation	3-2



AA82 InterMUSIC™ Stereo Intercom System SM09-1 Installation and Operation Manual

Section 1 Description

1.1 Introduction

Information in this section consists of product description, design features and specifications for the AA82 InterMUSIC™ Stereo Intercom System. All derivative product information shall be contained in the applicable manual supplement, which may be obtained from NAT as required.

Review all notes, warnings and cautions.

1.2 Product Description

The AA82 InterMusic™ Stereo Intercom System is a system for passenger entertainment and communications. The system is available in two models, the AA82-001 and AA82-060. The AA82-001 is compatible with AA80 intercoms and allows four stereo positions. The AA82-060 is compatible with AA83 intercoms and allows six stereo positions. Each is linked via the ICS Tie Line to the crew audio system.

The AA82 InterMUSIC™ Stereo Intercom offers the passengers full control of their intercom and entertainment functions. The front panel controls permit adjustment of Intercom level, VOX threshold and Music level. Internal adjustments set Receive level, Receive balance, ICS balance, ICS bass, Music muting and Music balance. These controls allow unique features such as making the intercom audio appear to be coming from the left and receive audio coming from the right, which is helpful in relating the audio to the source. The stereo audio is muted during intercom operation or when receive audio is detected, permitting greater intelligibility of in coming transmissions. A front panel annunciator allows easy visual setting of the VOX threshold and also indicates RX signal reception.

1.3 Design Features

The AA82 uses surface mount technology and provides true stereo music audio to the headset.

The InterMUSIC™ system employs NAT's unique audio processing, which reduces noise and tailors the frequency response to produce clean, crisp intercom audio.

High output power and low distortion results in better on-board communication and greatly reduces noise fatigue.

Employing highly integrated stereo audio processors, component numbers were substantially reduced and product reliability is increased.

With the reduction of component size, more features were incorporated (Adjustable music muting by intercom and receive audio, bass control of intercom and stereo audio).

Designed into the smallest possible chassis, it allows mounting in the remotest locations (usually close to the passengers).

The AA82's ICS Tie Line is fully compatible with existing NAT products, making it possible to chain multiple systems together (3 units max).

The unit has overvoltage and reverse voltage protection to insure operability in severe aircraft environments.



AA82 InterMUSIC™ Stereo Intercom System SM09-1 Installation and Operation Manual

1.4 Specifications

1.4.1 Electrical Specifications

Input Power	+11 to +32 Vdc
Supply Current	385 mA max. (full output power)
Headset Power	400 mW per channel (total power) 100 mW typical into each headset element (300 Ω /side) 4 headsets (AA82-001) 6 headsets (AA82-060)
Lighting	160 mA at 28 Vdc 600 mA at 5 Vdc
Modes of Operation	Voice track trigger circuit Adjustable threshold on panel 'Live' or 'Hot' mic by rotating VOX control counterclockwise
Indicators	Receive monitor (Green LED) VOX ICS triggered (Amber LED)
Front Panel Controls	ICS Volume Music Level VOX Threshold
Internal Side Panel Controls	RX Volume RX Balance ICS Balance Music Balance
Inputs (AA82-001)	4 microphone 'carbon equivalent', 250 mVrms for full output, 150 Ω input impedance 4 ICS keylines (active ground) for all users 2 music inputs compatible (left & right), configurable for portable CD/cassette only, phones compatible (3 Vp-p)
Inputs (AA82-060)	6 microphone 'carbon equivalent', 250 mVrms for full output, 150 Ω input impedance 6 ICS keylines (active ground) for all users 2 music inputs compatible (left & right), configurable for either portable CD/cassette, phones compatible (3 Vp-p) or CD changer Line Out compatible (100-500 mV @ 10 k Ω)
Inputs (all models)	1 radio input, 2.5 Vrms for full output, 1 k Ω input impedance 1 bi-directional ICS Tie Line, 1 Vp-p for full output, 2 k Ω input impedance



AA82 InterMUSIC™ Stereo Intercom System SM09-1 Installation and Operation Manual

Outputs (AA82-001)	4 aircraft stereo headsets (300 Ω /side) Note: Not designed for 8 Ω headsets.
Outputs (AA82-060)	6 aircraft stereo headsets (300 Ω /side) Note: Not designed for 8 Ω headsets.
Logic	ICS and RX audio both mute the music channel No emergency or transmit functions

1.4.2 Physical Specifications

Height	1.30" (33.0 mm)
Depth	5.60" (142.2 mm) excluding front panel controls
Width	2.60" (66.0 mm)
Weight	0.6 lbs (283.5 g) excluding external hardware
Mounting	Horizontal or vertical with reversible faceplate for through-panel mounting

1.4.3 Environmental Specifications

Temperature	-40 to +70°C (operating) -55 to +85°C (storage)
Altitude	25,000 feet max.
Humidity	95% Non-condensing

Section 1 ends



AA82 InterMUSIC™ Stereo Intercom System SM09-1 Installation and Operation Manual

Section 2 Installation

2.1 Introduction

Information in this section consists of unpacking and inspection procedures, installation procedures, post-installation checks and installation drawings for the AA82 InterMUSIC™ Stereo Intercom System.

Review all notes, warnings and cautions.

2.2 Unpacking and Inspection

Unpack the equipment carefully and locate the warranty card. Inspect the unit visually for damage due to shipping and report all such claims immediately to the carrier involved. Check that all items listed below are present before proceeding and report any shortage immediately to your supplier:

- Warranty Card
- Operators Manual
- Certificate of Conformity or Release Certification
- Installation kit with faceplate (crimp type connector)

2.2.1 Warranty

All Northern Airborne Technology Ltd. products are warranted for 2 years from date of installation by an authorized NAT dealer, to be free of defects in workmanship or performance. This warranty covers all materials and labour, but is exclusive of any transport to deliver the defective unit to and from NAT or its designated warranty repair center, or any labour to remove or re-install the defective unit in the aircraft. Contact NAT for any questions regarding this warranty, its applicability to your units and/or for return authorization. NAT is the final arbitrator concerning warranty administration. Units which have been physically damaged, burned, immersed in water or otherwise abused beyond the scope of normal use will not be considered for warranty. **WARRANTY IS VOID UNLESS THE PRODUCT IS INSTALLED BY AN AUTHORIZED NAT DEALER.** Product for which a warranty card is not returned shall be warranted from date of manufacture.

2.3 Continued Airworthiness

Maintenance of the AA82 InterMUSIC™ Stereo Intercom System is 'on condition' only. Periodic maintenance of this product is not required.



AA82 InterMUSIC™ Stereo Intercom System SM09-1 Installation and Operation Manual

2.4 Installation Procedures

2.4.1 Warnings

WARNING:
High volume settings can cause hearing damage.
Set the headset volume control to the minimum volume setting prior to conducting tests, and slowly increase the headset volume to a comfortable listening level.

2.4.2 Cautions

CAUTION:
DO NOT use mono aircraft headsets in this system. Mono aircraft headsets will short out one side of the AA82 power amplifier when installed in the stereo jacks. This may result in eventual unit failure. Use only stereo headsets with this system.

2.4.3 Cabling and Wiring

All wire shall be selected in accordance with the original aircraft manufacturer's Maintenance Instructions or AC43.13-1B Change 1, Paragraphs 11-76 through 11-78. Unshielded wire types shall qualify to MIL-W-22759 as specified in AC43.13-1B Change 1, Paragraphs 11-85, 11-86, and listed in Table 11-11. For shielded wire applications, use Tefzel MIL-C-27500 shielded wire with solder sleeves (for shield terminations) to make the most compact and easily terminated interconnect. Follow the connector map in Section 2.7 as required.

Allow 3" from the end of the shielded wiring to the shield termination to allow the connector hood to be easily installed. Reference the interconnect drawing in Section 2.7 for shield termination details. Note that the hood is a "clamshell" hood, and is installed after the wiring is complete. Aircraft harnessing shall permit the unit to be removed from the panel for easy access to all side adjustments. Do NOT mount the unit until all adjustments have been performed.

Maintain wire segregation and route wiring in accordance with the original aircraft manufacturers Maintenance Instructions.

Unless otherwise noted, all wiring shall be a minimum of 24 AWG, except power and ground lines, which shall be a minimum of 22 AWG. Reference the Interconnect drawing for additional specifications. Check that the ground connection is clean and well secured, and that it shares no path with any electrically noisy aircraft accessories such as blowers, turn and bank instruments or similar loads. Power to this unit must be supplied from a separate circuit breaker or fuse (fast blow), and not attached to any other circuit breaker without additional protection. Verify that the selected circuit breaker size and wire gauge are adequate for the installation using the techniques specified in AC43.13-1B Change 1, Paragraphs 11-47 through 11-51 and 11-66 through 11-69.



AA82 InterMUSIC™ Stereo Intercom System SM09-1 Installation and Operation Manual

2.4.4 Mounting

The AA82 InterMUSIC™ Stereo Intercom can be mounted in either a vertical or horizontal orientation. Place the adhesive backed drill template in an appropriate place on the instrument panel and drill through the indicated locations. The mounting nuts on the faceplate controls should not be removed at any time. The clearance holes for the nuts should be 3/8" to allow them to fit through the instrument panel. The unit is secured by three black Phillips screws, which require 5/32" holes.

- Notes:**
- 1) The clock mount faceplate used with the AA80 Series is not supplied.
 - 2) Perform all functional tests and adjustments prior to mounting. Secure the unit to the panel prior to flight.

2.4.5 Post Installation Checks

2.4.5.1 Voltage/Resistance Checks

Do not attach the AA82-xxx until the following conditions are met.

Check the following for the AA82-001:

- a) Check pin 1 for +11 to +32 Vdc relative to ground.
- b) Check pin 14 for continuity to ground (less than 0.5Ω).

Check the following for the AA82-060:

- a) Check pin 1 for +11 to +32 Vdc relative to ground.
- b) Check pin 16 for continuity to ground (less than 0.5Ω).

2.4.5.2 Power On Checks

Power up the aircraft's systems and confirm normal operation of all functions of the AA82-xxx. Reference Section 3 for specific operational details.

- a) Check that headsets are installed correctly.
- b) To verify proper operation, all functions and levels shall be checked in-flight.
- c) Check preset adjustments are completed before aircraft departure.

Upon satisfactory completion of all performance checks, make all required log book entries, electrical load, weight and balance amendments and other documentation as required by your local regulatory agency before releasing the aircraft for service.

2.5 Adjustments and Connections

All AA95/AMS4X Audio Controllers used with the AA82 must have the ICS Tie Line and Gain Modifications installed. This applies to units with a serial number less than 1918.

The AA82-xxx has internal trimpot adjustments accessible through holes in the right and left sides of the unit. The AA82-060 also has internal jumper settings for music input types. Reference Section 2.5.5 for jumper settings.



AA82 InterMUSIC™ Stereo Intercom System SM09-1 Installation and Operation Manual

2.5.1 Radio Settings

To achieve correct radio volume settings, check that the headset radio level is acceptable. This adjustment should be made with the radio volume set to about 50%. Adjust the headset volume control (if it exists) for something less than full volume, such as 75% (full output on active headsets will give the worst over-all signal to noise ratio, as it will increase the low level noise floor). Adjust the RX VOL on the side of the AA82 to a preferred level.

Check that the music is muting at this stage when a radio signal is received. If not, the radio itself set too low and must be increased at the radio to properly activate the internal muting circuit in the AA82. Once the radio settings are satisfactory, perform all other adjustments. The RX VOL trimpot sets only the radio level heard during normal operation and has no effect on any other function, including muting.

2.5.2 Setting Up Muting and Music

Rotate the front panel VOX potentiometer until the VOX indicator is off. The music audio can now be heard. Adjust the music to a comfortable level with the front panel potentiometer. If the music is louder in one ear than the other, the side panel MUSIC BAL control may need adjusting, although this could be a problem with your music source, as this adjustment should be correct from the factory.

With the front panel VOX potentiometer turned fully counter-clockwise (LIVE ICS, the indicator should be ON), adjust the MUSIC MUTE trimpot to the desired level of music audio in the background. This is the level the music will default to whenever it is muted and can range from OFF to only slightly muted as preferred.

2.5.3 Setting Balance and Bass Potentiometers

With the VOX control still in the LIVE ICS position, talk back and forth on the intercom to determine the voice quality. If more bass is desired, the ICS BASS potentiometer may be adjusted for the preferred tone. Check that this adjustment is compatible with the headsets and that it does not increase distortion. If the ICS audio seems distorted, reduce the ICS BASS potentiometer for best results. Some aircraft headsets do not have very good internal microphone amplifiers and achieve "noise reduction" by shunting the microphone with a large capacitor to reduce high frequency noise. This may make the voice very bass heavy and muffled. Best results were obtained in NAT testing with the following headsets:

Bose (may require re-wiring of plug for stereo)
David Clark (may require modification for stereo)

Most aircraft headsets do not do a good job of reproducing wide bandwidth music information, which seriously compromises the performance of the AA82. NAT will test any headset for system compatibility if the unit is supplied for evaluation with the AA82.

If you wish the ICS audio to come from a particular location (left to right), adjust the ICS BAL potentiometer for the desired position.

Note: If you have not controlled the Left/Right headset jack wiring, it may appear to change locations between different users.

Set the location to suit your preference, listen to an incoming radio transmission and position it (ideally) in the opposite location with the RX BAL trimpot. The best setup should give some perceived difference in



AA82 InterMUSIC™ Stereo Intercom System SM09-1 Installation and Operation Manual

location for these two sources (radio & ICS), as it will improve recognition of who is speaking in the system.

2.5.4 Other ICS Functions

Check all installed functions and check the ICS function for all users. The VOX potentiometer on the front controls all passengers. Adjust as needed for the best performance.

Note: Significantly different headsets may have different microphone characteristics, which affect VOX squelch settings.

Note: The David Clark M-7 microphone is more active than M-4 or M-1 microphones and may aggravate headset imbalance if used in a mixed system.

To test KEYED ICS operation of the AA82-060, be sure the VOX potentiometer is set fully clockwise and all ICS audio is shut off. Keying the ICS switches should activate the specific microphone involved.

Note: Each microphone is individually gated in the AA82-060 and only the microphone involved with a key signal is activated.

The front panel indicator should illuminate orange when there is activity on the intercom.

2.5.5 Music Selection (AA82-060 only)

The cover of the unit must be removed in order to access jumper locations. Reference Section 6 for Exploded View AA82\060\904-0 and Component Locator AA82\060\924-0 drawings.

Note: The AA82 is a static sensitive device. Use proper ESD handling procedures when the cover is removed.

To gain access to the jumpers, remove the cover from the AA82. Remove the top PCB by removing the three pan head screws and carefully lifting it straight up. When reassembling the unit check that the pins and connector are aligned properly before screwing the PCB down.

The two types of music inputs are configured by the position of jumpers JP101 and JP102, located on the main PCB near the access hole for Q101. Music input type is determined as shown in Table 1:

Music Input Type	Jumper Positions
Low Z/Portable cassette/CD compatible	JP101 and JP102 Installed
High Z/CD changer compatible	JP101 and JP102 Removed

Table 1
Music Input Type and Jumper Position

2.5.6 Final Check

Before leaving the aircraft, check that the mating connector is securely fastened to the AA82 and the unit is securely fastened to the aircraft panel.



AA82 InterMUSIC™ Stereo Intercom System SM09-1 Installation and Operation Manual

2.6 Accessories Required

Installation kit p/n AA82-001-IKC (25 pin D-min Female Crimp) is required to complete the installation. The kit includes NAT Part No. D25SL-IKC.

AA82-001-IKC consists of:

Quantity	Description	NAT Part No.
1	D-min 25 Socket Housing	20-21-025
25	MS Crimp Socket	20-26-901
1*	Jack Screw Set	20-27-002
1*	Lock Clip Set	20-27-004
1	25 Pin Connector Hood	20-29-026
3	5/8" 6-32 Black Pan Head Screw	25-11-427
2	Fluted 1/8" Knob	40-18-002
1	Fluted 1/8" Music Knob	40-18-MUS2
1	Hole Overlay	43-10-083
1	Rectangular Faceplate	50-04-821

* Use as required.

Installation kit p/n AA82-060-IKC (44 pin D-min Female Crimp) is required to complete the installation. The kit includes NAT Part No. D44SL-IKC.

AA82-060-IKC consists of:

Quantity	Description	NAT Part No.
1	D-min 44 Socket Housing	20-20-044
44	Mini D Crimp Socket	20-26-703
1*	Jack Screw Set	20-27-002
1*	Lock Clip Set	20-27-004
1	25 Pin Connector Hood	20-29-026
3	5/8" 6-32 Black Pan Head Screw	25-11-427
1	Fluted 1/8" ICS Knob	40-18-ICS2
1	Fluted 1/8" Music Knob	40-18-MUS2
1	Fluted 1/8" VOX Knob	40-18-VOX2
1	Hole Overlay	43-10-080
1	Rectangular Faceplate	50-04-821

* Use as required.



AA82 InterMUSIC™ Stereo Intercom System SM09-1 Installation and Operation Manual

2.7 Installation Drawings

Use of the "#" symbol in the REV. column indicates that the document is listed elsewhere in the manual. Refer to the applicable NAT Part No. to locate the referenced document.

DOCUMENT	REV.	DESCRIPTION	TYPE	SERIAL NO.
AA82-001				
AA82\001\302-0	1.02	InterMUSIC Stereo Intercom	Block Diagram	All
AA82\001\403-0	1.01	InterMUSIC Stereo Intercom	Interconnect	All
AA82\001\405-0	1.01	InterMUSIC Stereo Intercom	Connector Map	All
AA82\001\921-0	1.00	InterMUSIC Stereo Intercom	Mounting Plate	All
AA82-060				
AA82\060\302-0	1.01	InterMUSIC Stereo Intercom	Block Diagram	All
AA82\060\403-0	1.20	InterMUSIC Stereo Intercom	Interconnect	1338 to 1477
AA82\060\403-0	1.31	InterMUSIC Stereo Intercom	Interconnect	1478 and up
AA82\060\405-0	1.02	InterMUSIC Stereo Intercom	Connector Map	All
AA82\001\921-0	#	InterMUSIC Stereo Intercom	Mounting Plate	

Section 2 ends following the above documents

REVISIONS

REV	DESCRIPTION	DATE	BY
1.01	FORMAT CHANGES.	MAY 17/94	TM
1.02	ECR #1913 - '4 PASSENGERS' WAS '4 OR 6 PASSENGERS', ADDED NOTE, FORMAT CHANGES.	APR 17/01	TAT

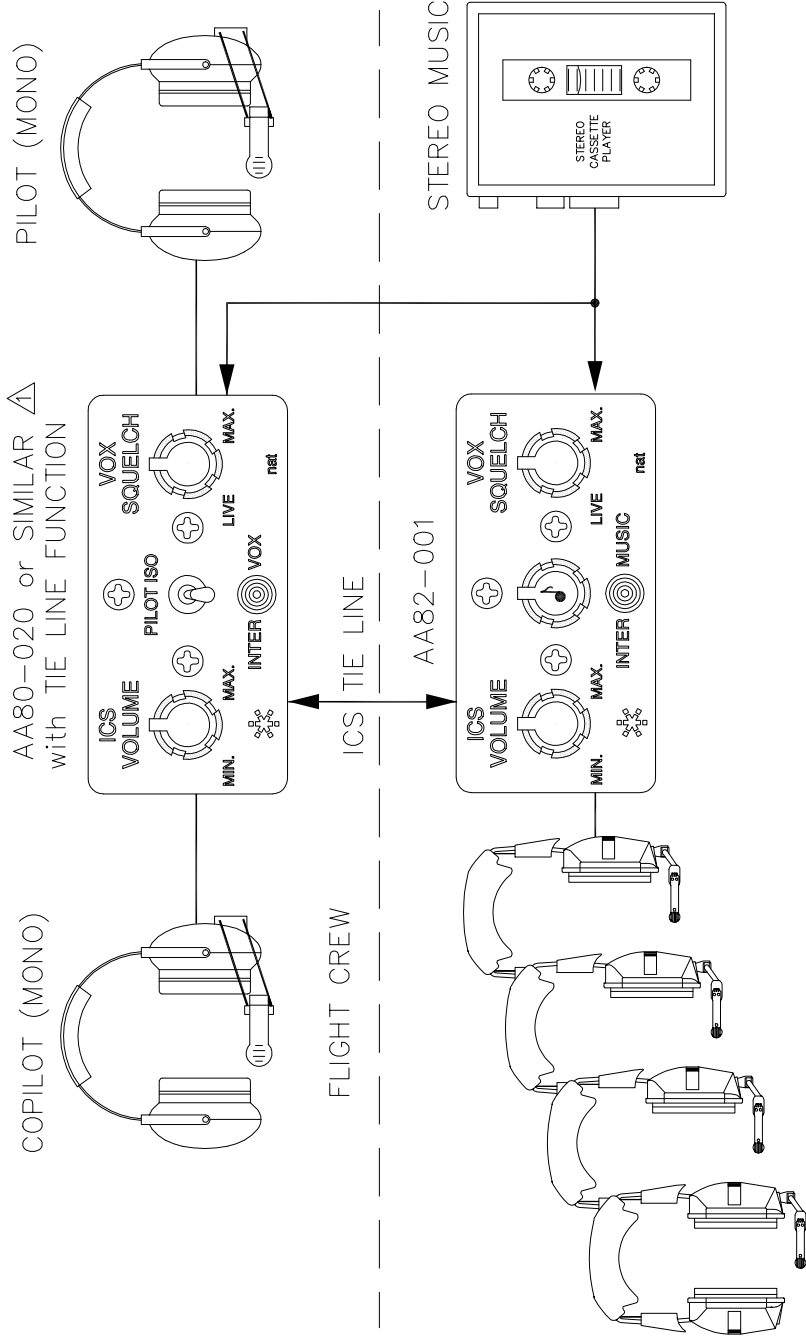

PROPRIETARY AND CONFIDENTIAL TO NAT LTD.

DESIGNED	KV			
DRAWN	SM			
DATE	JAN 3/91	TITLE		
CHECKED	NAT 114	INTERMUSIC STEREO INTERCOM		
APPROVED	NAT 113	SIZE	CAGE CODE	REV. SHEET
FILE	302-0102.DWG	A	3AB01	1.02 1/1
	DWG. TYPE	BLOCK DIAGRAM	DWG. NO.	AA82\001\302-0

nat NORTHERN AIRBORNE TECHNOLOGY LTD.

NOTE:
 ▲ REFER TO THE AA80 SERVICE MANUAL, SM08, FOR INTERCONNECT INFORMATION.

AA82-001 EXTERNAL CONNECTIONS
J101 (25 PIN)

AIRFRAME CONNECTIONS

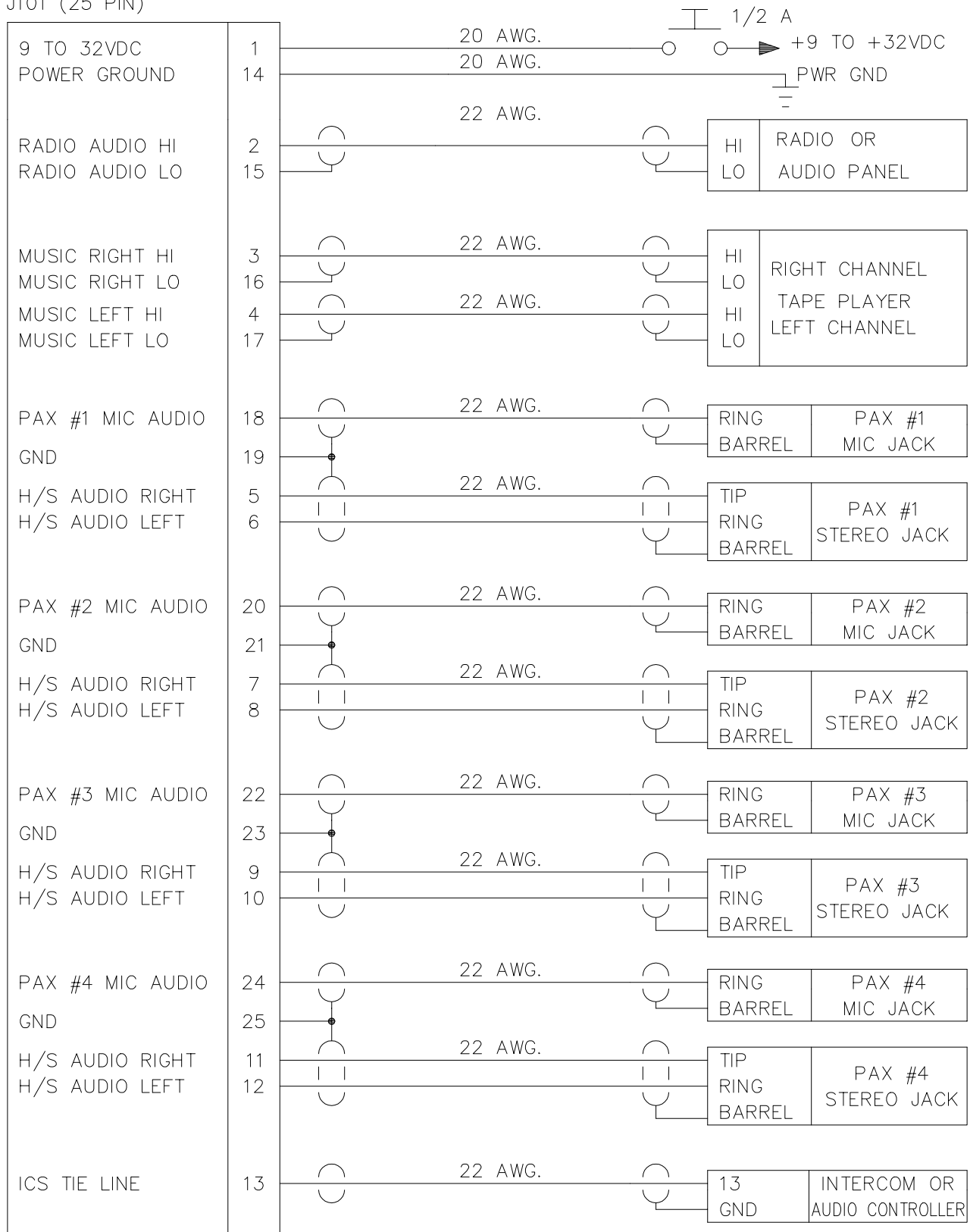

Confidential and Proprietary to NAT

REVISION	DATE	*nat NORTHERN AIRBORNE TECHNOLOGY LTD.			
-	OCT 30/90	DESIGNED BY	DESCRIPTION		
1.01	MAY 24/94	K. VEITCH	INTERMUSIC STEREO INTERCOM		
		DRAWN BY	PART NUMBER	DRAWING TYPE	SHEET
		K. VEITCH	AA82-001	INTERCONNECT	1/1
		APPROVED BY	DRAWING NUMBER	FILE NUMBER	
		NAT R&D	AA82-001\403-0	AA82-001\403-0101	
		101			

INTERMUSIC
INTERCONNECT

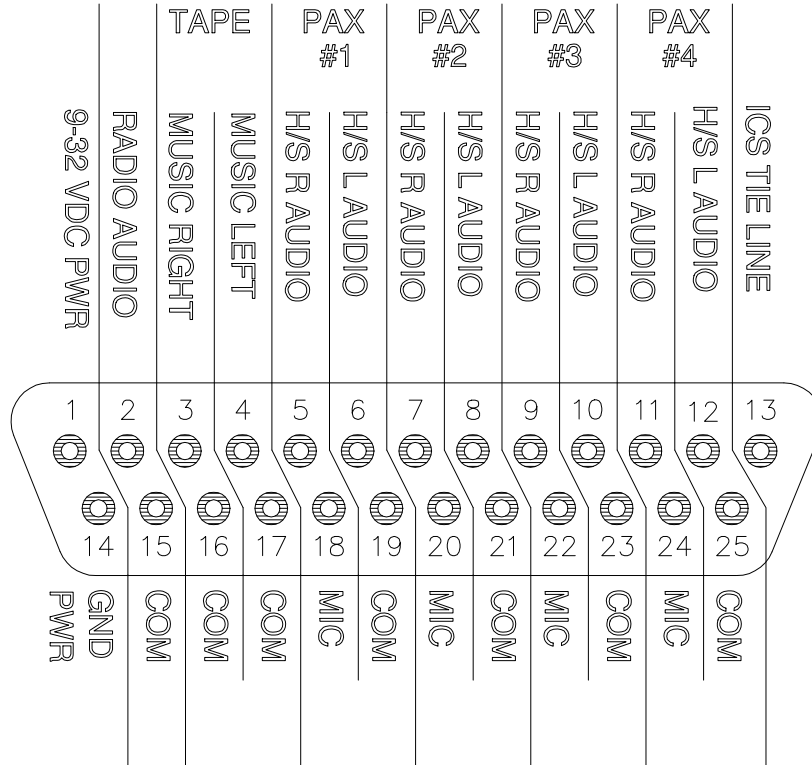

Confidential and Proprietary to NAT

REVISION	DATE	*nat NORTHERN AIRBORNE TECHNOLOGY LTD.			
-	MAY 10/90	DESIGNED BY	DESCRIPTION		
1.01	MAY 16/94	K. VEITCH	INTERMUSIC STEREO INTERCOM		
		DRAWN BY	PART NUMBER	DRAWING TYPE	SHEET
		K. VEITCH	AA82-001	CONNECTOR MAP	1/1
		APPROVED BY	DRAWING NUMBER	FILE NUMBER	
		NAT R&D	AA82-001\405-0	AA82-001\405-0101	
		101			

AA82 DRILL TEMPLATE

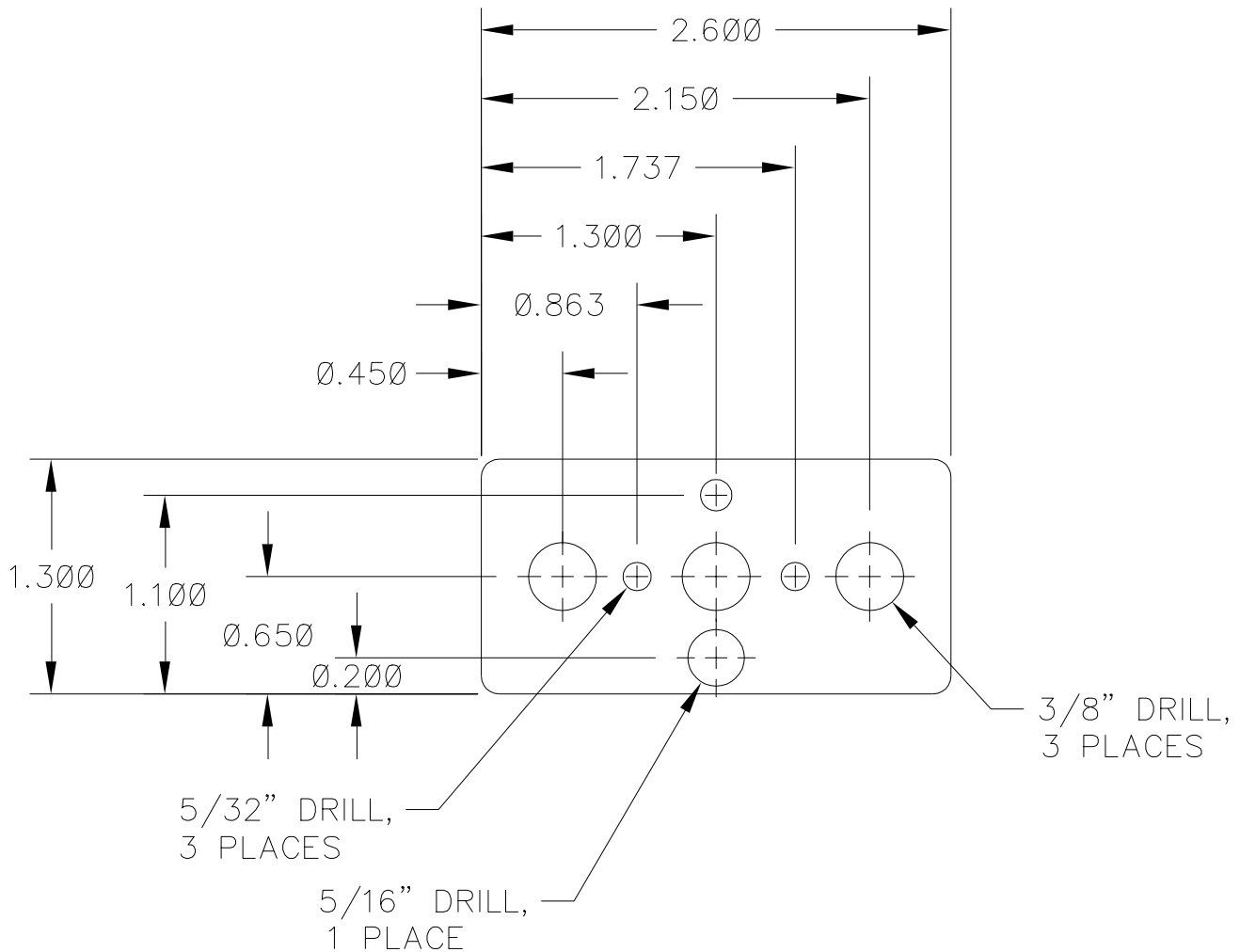

NOTE: ALL TOLERANCES ± 0.01

Confidential and Proprietary to NAT

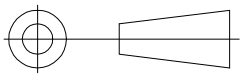
REVISION	DATE	TOLERANCES UNLESS STATED OTHERWISE	*nat NORTHERN AIRBORNE TECHNOLOGY LTD.		
1.00	MAY 17/94	0.X=+/-0.030 DIM. IN INCHES 0.XX=+/-0.010 0.XXX=+/-0.005 0.XXXX=+/-0.0005 ANGLE=+/- 0.5 DEG.	DESIGNED BY		
			DESCRIPTION		
			K.V.		
			DRAWN BY	PART NUMBER	DRAWING TYPE
			T. MASTERS	AA82	MOUNTING PLATE
THIRD ANGLE PROJECTION			APPROVED BY	DRAWING NUMBER	FILE NUMBER
			NAT R&D	AA82-001\921-0	AA82-001\921-0100
			101		

REVISIONS

REV	DESCRIPTION	DATE	BY
1.01	ECR #1913 - 'UP TO 6 PASSENGERS' WAS '4 OR 6 PASSENGERS'. ADDED NOTE, FORMAT CHANGES.	APR 18/01	TAT

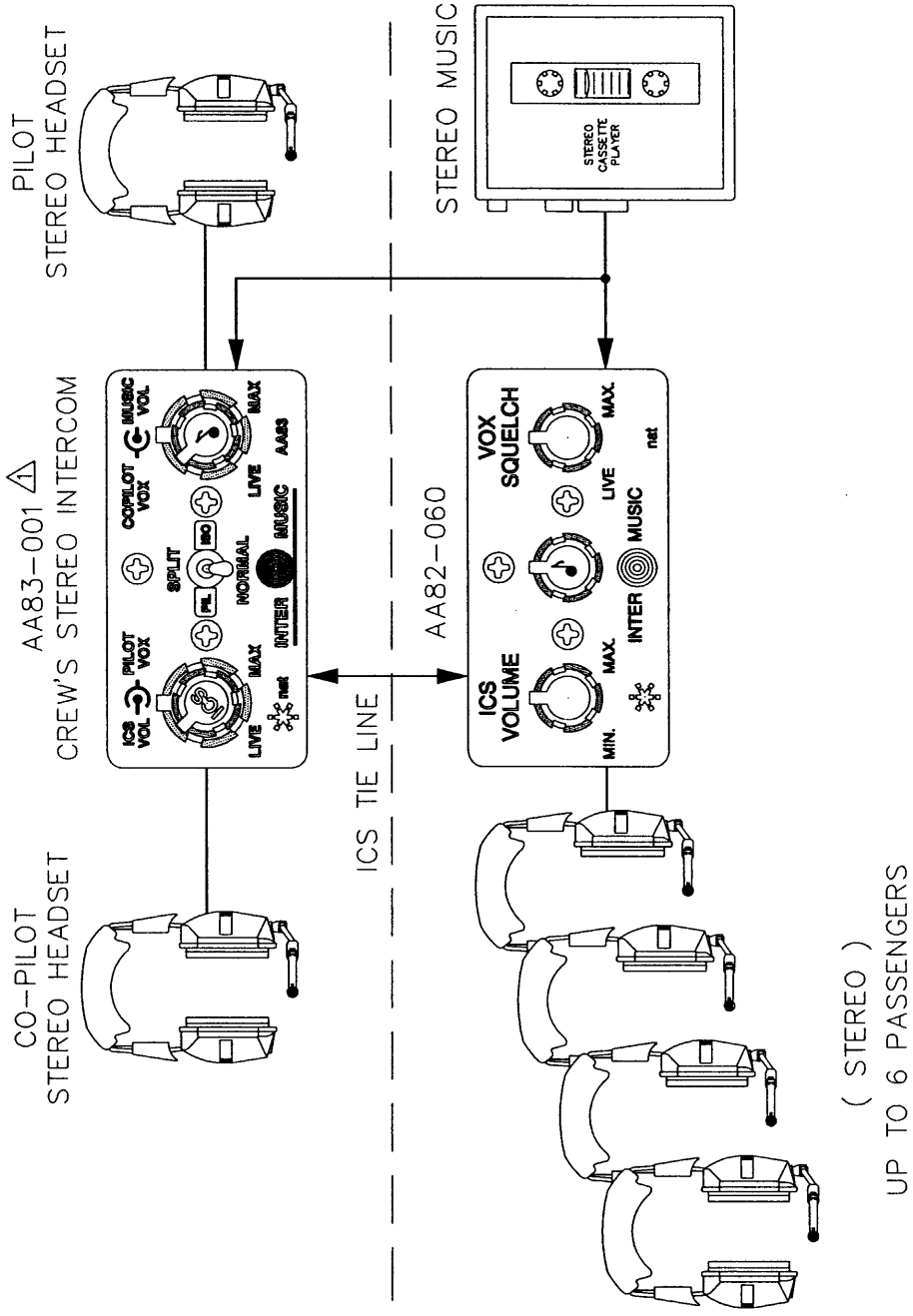

PROPRIETARY AND CONFIDENTIAL TO NAT LTD.

DESIGNED	KV	TITLE	
DRAWN	TM	INTERMUSIC STEREO INTERCOM	
DATE	MAY 16/94	SIZE	CAGE CODE
CHECKED	NAT 114	A	3AB01
APPROVED	NAT 113	PART NO.	AA82-060
FILE	302-0101.DWG	DWG. TYPE	BLOCK DIAGRAM
		DWG. NO.	AA82\060\302-0

nat NORTHERN AIRBORNE TECHNOLOGY LTD.

NOTE:
 ▲ REFER TO THE AA83 SERVICE MANUAL, SM09,
 FOR INTERCONNECT INFORMATION.

REVISIONS			
REV	DESCRIPTION	DATE	BY
1.01	FORMAT CHANGES ONLY	MAY 16/94	KV
1.10	J101 - PIN 31 ADDED.	AUG 16/94	KV
1.20	ECR #553 - WIRE GAUGE CHANGED	SEPT 6/96	TGM

AA82-060 EXTERNAL CONNECTIONS
J101 (44 PIN)

AIRFRAME CONNECTIONS

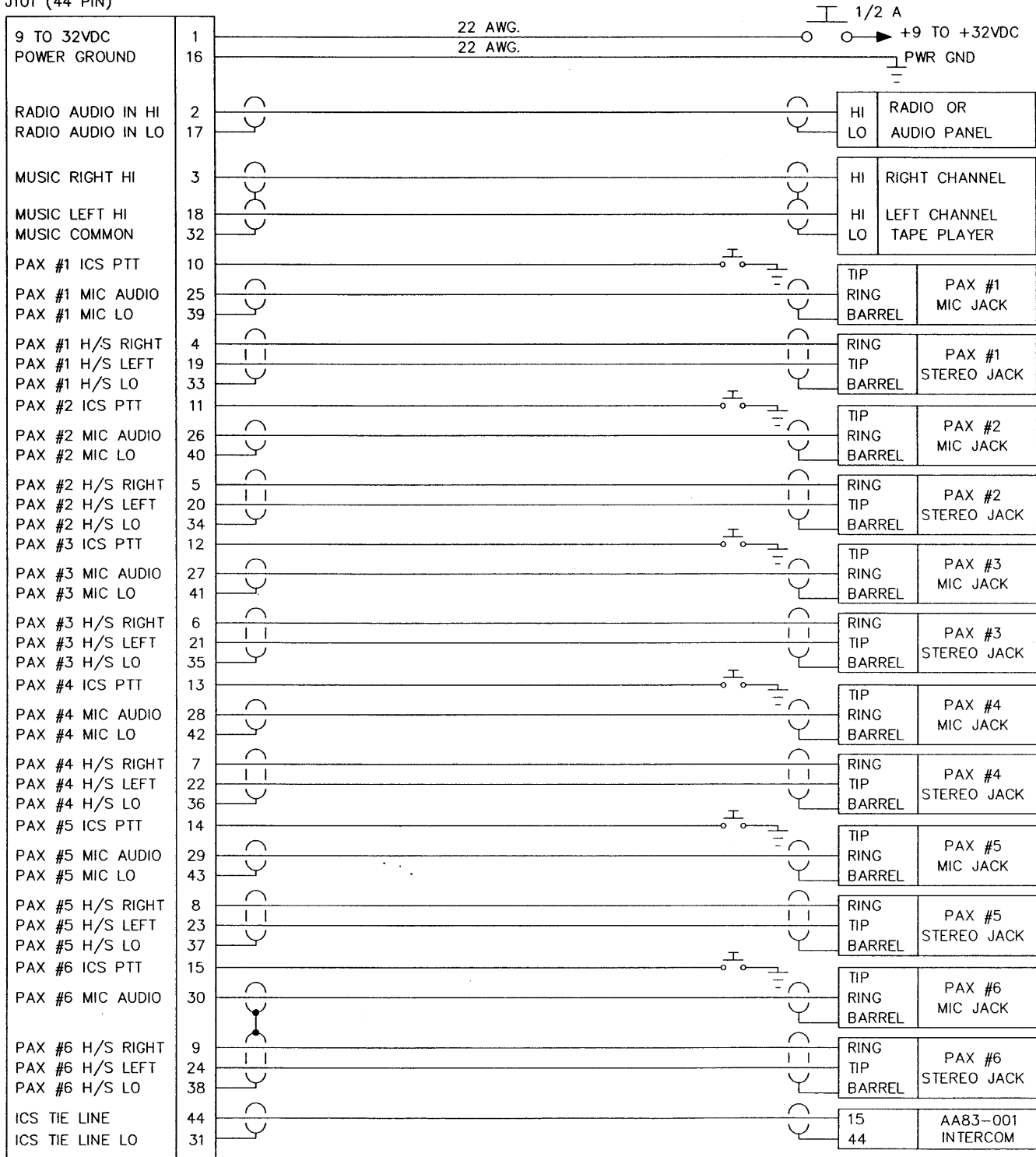

NOTE:

ALL WIRE SHOULD BE 24AWG UNLESS OTHERWISE NOTED.

DESIGNED	KV	 NAT NORTHERN AIRBORNE TECHNOLOGY LTD.				
DRAWN	KV					
DATE	OCT 30\90	TITLE INTERMUSIC STEREO INTERCOM				
CHECKED	NAT 200					
APPROVED	NAT 107	SIZE	CAGE CODE	PART NO.	REV.	SHEET
		A	3AB01	AA82-060	1.20	1/1
FILE	403-0120.DWG	DWG. TYPE	INTERCONNECT	DWG. NO.	AA82\060\403-0	

REVISIONS			
REV	DESCRIPTION	DATE	BY
	FOR PREVIOUS REVISIONS SEE 401-0130.DWG		
1.30	ECR #720 - WIRE GAUGE WAS 22/24AWG.	MAR 18/97	TGM
1.31	ECR #588 - UPDATED TO CURRENT NAT STANDARDS.	NOV 10/00	TAT

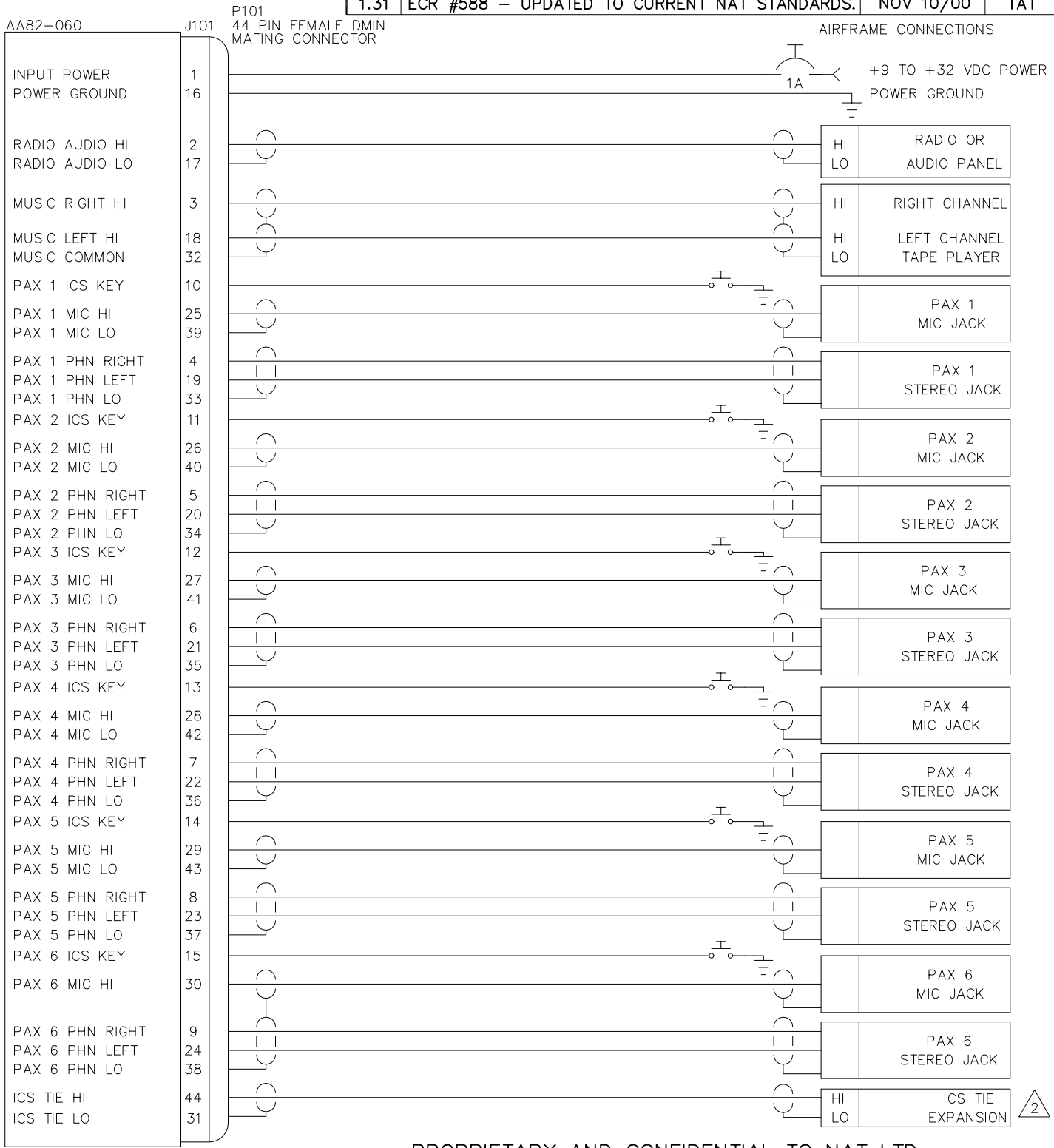

PROPRIETARY AND CONFIDENTIAL TO NAT LTD.

NOTES:

- ALL WIRES SHOULD BE 22 AWG UNLESS OTHERWISE SPECIFIED. ALL WIRE SHOULD BE IN ACCORDANCE WITH MIL-W-22759. ALL SHIELDED WIRE/CABLE SHOULD BE IN ACCORDANCE WITH MIL-C-27500.

2 TO BE USED FOR EXPANSION OF INTERCOM SYSTEM ONLY. REFER TO INSTALLATION MANUAL FOR DETAILS.

DESIGNED	KV	 NAT NORTHERN AIRBORNE TECHNOLOGY LTD.	TITLE INTERMUSIC STEREO INTERCOM			
DRAWN	KV					
DATE	OCT 30/90	REV. SHEET 1.31 1/1				
CHECKED	NAT 114 NAT 223					
APPROVED	NAT 113	SIZE	CAGE CODE	PART NO.	REV.	SHEET
FILE	403-0131.DWG	A	3AB01	AA82-060	1.31	1/1
DWG. TYPE		INTERCONNECT		DWG. NO.		AA82\060\403-0

REVISIONS			
REV	DESCRIPTION	DATE	BY
1.01	FORMAT CHANGES.	MAY 17/94	-
1.02	ECR #588 - PIN 31 AND 32 WERE GND, UPDATED TO CURRENT NAT STANDARDS.	AUG 11/00	TAT

P101
44 PIN FEMALE DMIN
MATING CONNECTOR

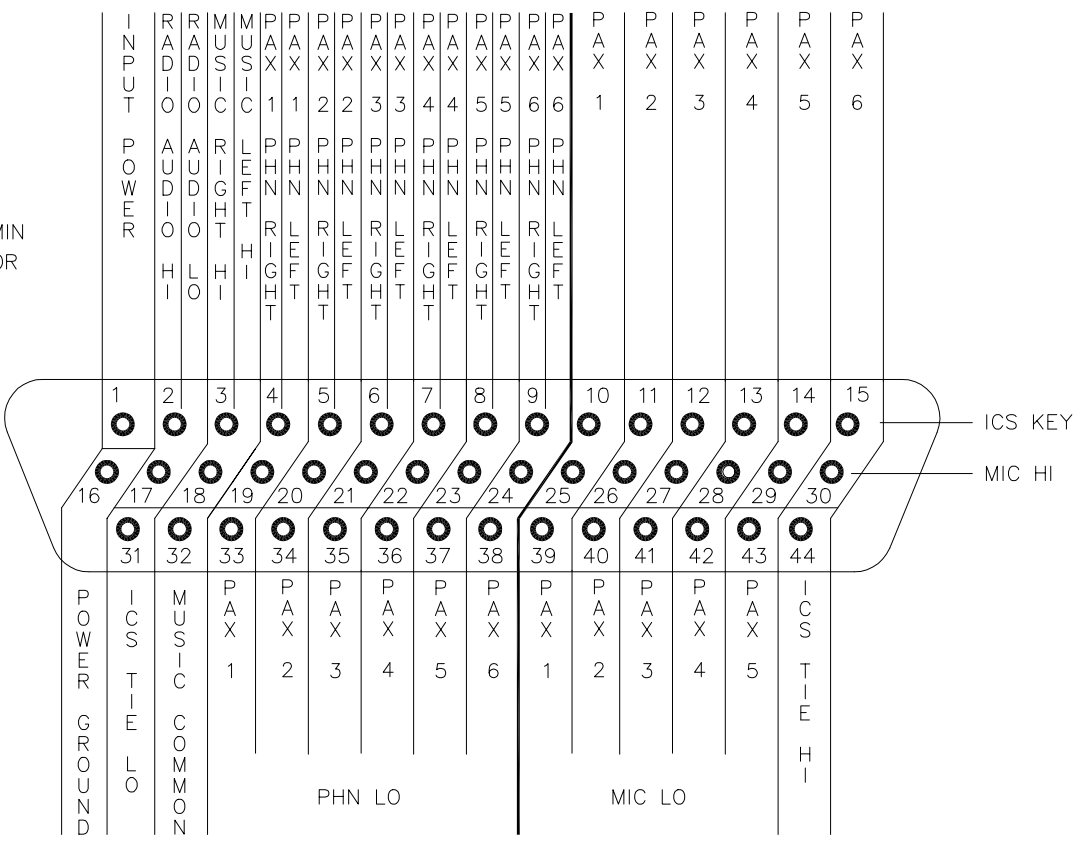

PROPRIETARY AND CONFIDENTIAL TO NAT LTD.

DESIGNED	KV	 NAT NORTHERN AIRBORNE TECHNOLOGY LTD.				
DRAWN	KV					
DATE	NOV 21/91	TITLE				
CHECKED	NAT 223	INTER MUSIC INTERCOM				
APPROVED	NAT 113	SIZE	CAGE CODE	PART NO.	REV.	SHEET
		A	3AB01	AA82-060	1.02	1/1
FILE	405-0102.DWG	DWG. TYPE		CONNECTOR MAP	DWG. NO. AA82\060\405-0	



AA82 InterMUSIC™ Stereo Intercom System SM09-1 Installation and Operation Manual

Section 3 Operation

3.1 Introduction

Information in this section consists of functional and operational procedures for the AA82 InterMUSIC™ Stereo Intercom System.

3.2 General Information

The AA82 is available in two models, the AA82-001 and AA82-060. Both are designed for passenger entertainment and communications. The AA82-001 is compatible with AA80 series intercom and allows four stereo positions. The AA82-060 is compatible with AA83 series intercoms and allows six stereo positions. Each is linked via the bi-directional ICS Tie Line to the crew audio system.

3.3 Controls and Indicators

The front panel controls shown in Figure 1 permit user adjustment of frequently needed signals, such as Intercom Audio Level (ICS Volume), Microphone VOX Threshold (VOX Squelch) and Music Level (Musical Note).

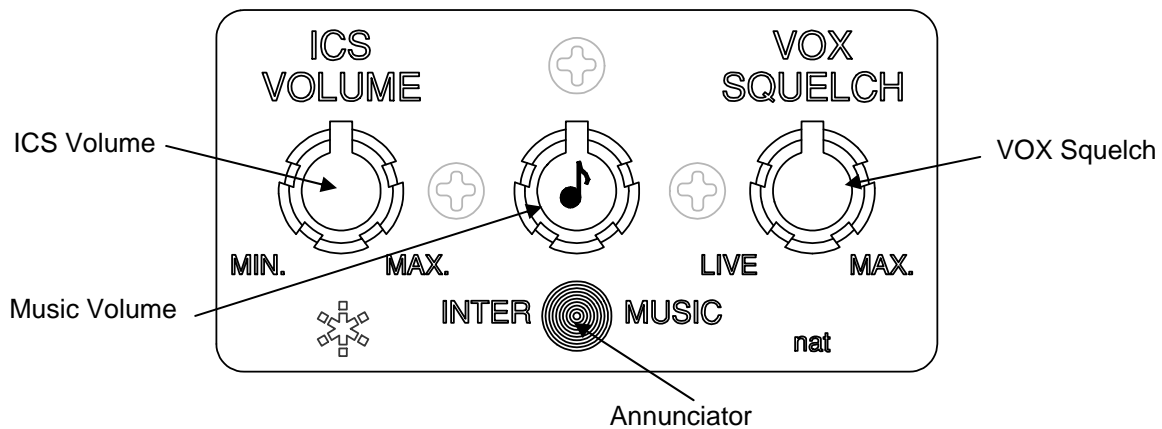

Figure 1: Front Panel Controls

Internal adjustments set default values for Receive Audio Level, Receive Balance, ICS Balance, ICS Bass, Music Muting and Music Balance. These extensive controls allow some unique features, such as making the intercom and radio sources appear from distinct listening space positions to aid in recognition.

Music Muting allows the dynamic range of the music muting function to be set to suit individual preferences and Bass adjustments allow tailoring to the exact characteristics of the headsets chosen. Music muting occurs in a smooth, fast attack/slow return sequence, for maximum comfort and clarity of communication in all modes.



AA82 InterMUSIC™ Stereo Intercom System SM09-1 Installation and Operation Manual

3.3.1 Stereo & Intercom Special Features

The stereo music audio is muted during intercom operation and when radio receive audio is detected, permitting greater intelligibility of incoming transmissions. The AA82 Muting adjustment ranges from complete music muting to gentle background music on command, with a fast attack and slow level return for optimum user comfort. Each microphone is individually gated for the best possible noise performance during VOX operation. A front panel annunciator allows easy visual setting of the VOX threshold and also indicates radio signal reception.

3.3.2 Logic Explanation

When ICS or RX functions are active, any music will be muted quickly as shown in Table 1. The music will slowly return when transmission is completed. The degree of muting is set at the time of installation. The relative volume of the music can be changed from the front panel by adjusting the music volume knob marked with a musical note.

Active: Function being used

Muted: Functions that are overridden by the active condition

Idle: Functions that are not active, but still available for use

Music	ICS	RX
Active	Idle	Idle
Muted	Active	Idle
Muted	Idle	Active
Muted	Active	Active

Table 1
Music Muting

3.3.3 Tie/Split Operation

The crew audio system that the AA82 is connected to may have a Tie/Split mode of operation. The crew's Tie/Split switch connects or disconnects the ICS Tie Line from the passengers' intercom system. Intercom between the passengers is maintained, but they are cut off from the crew ICS and radio audio. Many different circuit combinations can be set up depending on what device is hooked to the Tie Line.

Section 3 ends
