

N301A Series Custom Configuration Chart

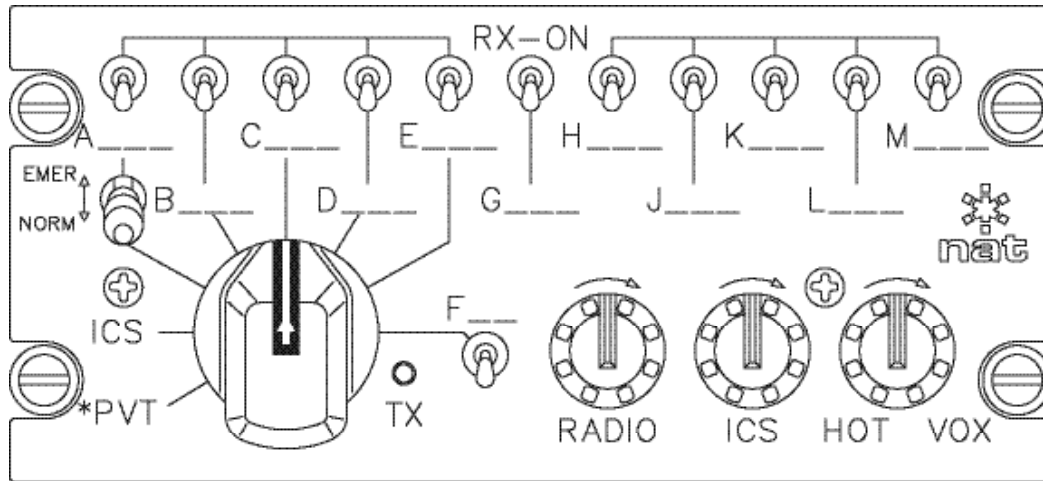

Installation Information:

Airframe Type:

Number of Controls/Aircraft:

Control Location(s):

Functions:

Similar to existing model:

Low or High Impedance:

NAT or Andrea Tie-Line*:

#1 Direct Input:
(Through radio volume control)

#2 Direct Input:
(Through radio volume control)

#3 Direct Input:
(Emergency mode)

#4 Direct Input:

Special Knobs:

Special Lighting:
(Must be DC; default - 28 VDC natural)

Legends:

A:	G:
B:	H:
C:	J:
D:	K:
E:	L:
F:	M:

Toggle switch positions A - E should be used for transceivers. These may be remapped to RX inputs if needed, but the corresponding TX position will be eliminated. Position F may be used for either a transceiver or PA function.

Toggle switch positions G - M must be receiver inputs only.

Lighted knobs are standard on this control. A smaller TX select knob can be used but is not lighted.

Other Special Functions:

**PVT function only available when using the Andrea Tie-Line option.*